

VMM0604

Vansco Multiplexing Module (VMM) 0604

User Manual HY33-5003-IB/US
Ed. 01/2011

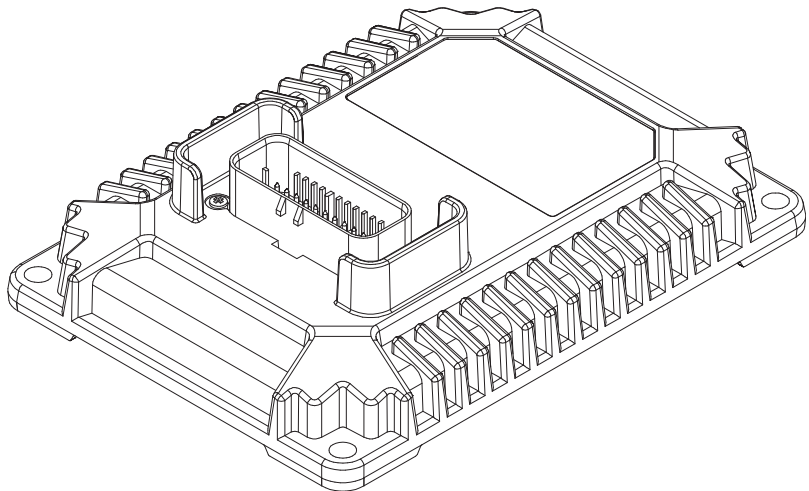

UM-VMM0604-836001-1.5-201101-04



Parker Hannifin Corporation
Electronic Controls Division
1305 Clarence Avenue
Winnipeg, MB R3T 1T4 Canada
Office +1 204 452 6776
Fax +1 204 478 1749

<http://www.parker.com/ecd>
<http://www.vansco.ca>
<http://www.iqan.com>

Copyright 2011 © Parker Hannifin Corporation. All rights reserved. No part of this work may be reproduced, published, or distributed in any form or by any means (electronically, mechanically, photocopying, recording, or otherwise), or stored in a database retrieval system, without the prior written permission of Parker Hannifin Corporation in each instance.

 **Warning!**

FAILURE OR IMPROPER SELECTION OR IMPROPER USE OF THE PRODUCTS AND/OR SYSTEMS DESCRIBED HEREIN OR RELATED ITEMS CAN CAUSE DEATH, PERSONAL INJURY AND PROPERTY DAMAGE.

- This document and other information from Parker Hannifin Corporation, its subsidiaries and authorized distributors provide product and/or system options for further investigation by users having technical expertise.
- The user, through its own analysis and testing, is solely responsible for making the final selection of the system and components and assuring that all performance, endurance, maintenance, safety and warning requirements of the application are met. The user must analyze all aspects of the application, follow applicable industry standards, and follow the information concerning the product in the current product catalog and in any other materials provided from Parker or its subsidiaries or authorized distributors.
- To the extent that Parker or its subsidiaries or authorized distributors provide component or system options based upon data or specifications provided by the user, the user is responsible for determining that such data and specifications are suitable and sufficient for all applications and reasonably foreseeable uses of the components or systems.

Offer of Sale

The items described in this document are hereby offered for sale by Parker Hannifin Corporation, its subsidiaries or its authorized distributors. This offer and its acceptance are governed by the provisions stated in the "Offer of Sale" elsewhere in this document, or available at www.parker.com.

Contents

| | |
|---|-----------|
| 1. Introduction | 6 |
| 1.1. Safety symbols | 6 |
| 2. Precautions | 7 |
| 2.1. General safety regulations | 7 |
| 2.1.1. Construction regulations | 8 |
| 2.1.2. Safety during installation | 8 |
| 2.1.3. Safety during start-up | 8 |
| 2.1.4. Safety during maintenance and fault diagnosis | 8 |
| 3. Understanding the VMM0604 | 9 |
| 4. How to Use this Manual | 11 |
| 4.1. Diagram Conventions | 11 |
| 5. Quick Start | 13 |
| 5.1. Overview | 13 |
| 5.2. Gather Required Materials | 13 |
| 5.3. Install the Required Software Tools | 14 |
| 5.3.1. Install the Data Link Adaptor (DLA) Driver Software | 14 |
| 5.4. Connect the VMM0604 to a Development System | 15 |
| 5.4.1. Power Up the Development System | 16 |
| 5.5. Create and Download Ladder Logic Software Applications | 16 |
| 6. Inputs | 17 |
| 6.1. General Purpose Inputs | 17 |
| 6.1.1. General Purpose Used as Programmable Digital Input | 18 |
| 6.1.2. General Purpose Used as Analog Input | 19 |
| 6.1.3. General Purpose Used as AC-Coupled Frequency Input | 23 |
| 6.1.4. General Purpose Used as DC-Coupled Frequency Input | 25 |
| 6.2. Digital Inputs | 28 |
| 6.2.1. Programmable Digital Inputs | 28 |
| 6.2.2. Power Control Digital Input | 28 |
| 6.2.3. Addressing Digital Inputs | 29 |
| 7. Outputs | 32 |
| 7.1. VMM0604 High-Side Outputs | 32 |
| 7.1.1. High-Side Output Capabilities | 32 |
| 7.1.2. High-Side Output Installation Connections | 33 |
| 7.1.3. High-Side Output Diagnostics and Fault Protection | 34 |
| 7.2. VMM0604 Low-Side Outputs with Current Sense | 35 |
| 7.2.1. Low-Side Outputs with Current Sense Capabilities | 35 |
| 7.2.2. Low-Side Outputs with Current Sense Configuration Options | 37 |
| 7.2.3. Low-Side Outputs with Current Sense Installation Connections | 37 |
| 7.2.4. Low-Side Outputs with Diagnostics and Fault Protection | 37 |

| | |
|--|-----------|
| 8. VMM0604 Diagnostic LEDs | 39 |
| 8.1. Input LEDs | 39 |
| 8.2. Output LEDs | 39 |
| 8.3. Power LED | 39 |
| 8.4. Network LED | 39 |
| 9. Power | 40 |
| 9.1. Logic and Output Power | 40 |
| 9.1.1. Logic and Output Power Capabilities | 40 |
| 9.1.2. Logic and Output Power Installation Connections | 41 |
| 9.2. Sensor Power | 42 |
| 9.2.1. Sensor Power Capabilities | 42 |
| 9.2.2. Sensor Power Installation Connections | 43 |
| 10. Communication | 44 |
| 10.1. Controller Area Network (CAN) | 44 |
| 10.1.1. J1939 CAN Capabilities | 44 |
| 10.1.2. J1939 CAN Installation Connections | 44 |
| 11. Connectors | 46 |
| 11.1. Mating Connector Part Numbers | 46 |
| 11.2. Connector Pin-outs | 46 |
| 12. Installing a VMM0604 into a Vehicle | 48 |
| 12.1. Mechanical Guidelines | 48 |
| 12.1.1. VMM0604 Dimensions | 48 |
| 12.1.2. Selecting a Mounting Location | 48 |
| 12.1.3. Mounting the VMM0604 to a Vehicle | 50 |
| 12.2. Electrical Guidelines | 50 |
| 12.2.1. Designing the Vehicle Harness | 50 |
| 12.2.2. Connecting the Vehicle Harness to the VMM0604 | 50 |
| 13. Application Examples | 51 |
| 13.1. Implementing Safety Interlocks | 51 |
| 13.2. Controlling Indicator Lights | 52 |
| 13.3. Controlling a Proportional Valve | 54 |
| 13.4. Controlling Motor Speed | 55 |
| 13.5. Using one Analog Input as Two Digital Inputs | 55 |
| 13.6. Controlling a Linear Actuator | 56 |
| 13.7. Connecting Various Sensors | 57 |
| 13.7.1. Open Collector | 58 |
| 13.7.2. Variable Resistance | 58 |
| 13.7.3. Variable Reluctance | 59 |
| 13.7.4. Switch | 60 |
| 13.7.5. Voltage | 61 |
| 13.7.6. CMOS | 62 |

| | |
|--|-----------|
| 13.7.7. Potentiometer (Ratiometric) | 62 |
| 14. Startup | 64 |
| 14.1. Start-up procedures | 64 |
| 14.1.1. Starting the control system | 64 |
| 14.1.2. Prepare for system start | 65 |
| 14.1.3. Start the system | 65 |
| 15. Appendix A | 66 |
| 15.1. VMM0604 Technical Overview | 66 |
| 15.2. Frequently Asked Questions (FAQ) | 68 |
| 15.3. Troubleshooting | 71 |
| 16. Glossary of Terms | 72 |
| 17. Index | 79 |

1. Introduction

These instructions are meant as a reference tool for the vehicle manufacturer's design, production, and service personnel.

The user of this manual should have basic knowledge in the handling of electronic equipment.

1.1. Safety symbols

Sections regarding safety, marked with a symbol in the left margin, must be read and understood by everyone using the system, carrying out service work or making changes to hardware and software.

The different safety levels used in this manual are defined below.



WARNING

Sections marked with a warning symbol in the left margin, indicate that a hazardous situation exists. If precautions are not taken, this could result in death, serious injury or major property damage.



CAUTION

Sections marked with a caution symbol in the left margin, indicate that a potentially hazardous situation exists. If precautions are not taken, this could result in minor injury or property damage.



NOTICE

Sections marked with a notice symbol in the left margin, indicate there is important information about the product. Ignoring this could result in damage to the product.

Contact the manufacturer if there is anything you are not sure about or if you have any questions regarding the product and its handling or maintenance.

The term "manufacturer" refers to Parker Hannifin Corporation.

2. Precautions

2.1. General safety regulations

Work on the hydraulics control electronics may only be carried out by trained personnel who are well-acquainted with the control system, the machine and its safety regulations.



WARNING

Mounting, modification, repair and maintenance must be carried out in accordance with the manufacturer's regulations. The manufacturer has no responsibility for any accidents caused by incorrectly mounted or incorrectly maintained equipment. The manufacturer does not assume any responsibility for the system being incorrectly applied, or the system being programmed in a manner that jeopardizes safety.



WARNING

Damaged product may not be used. If the control system shows error functions or if electronic modules, cabling or connectors are damaged, the system shall not be used.



WARNING

Electronic control systems in an inappropriate installation and in combination with strong electromagnetic interference fields can, in extreme cases, cause an unintentional change of speed of the output function.



NOTICE

As much as possible of the welding work on the chassis should be done before the installation of the system. If welding has to be done afterwards, the electrical connections on the system must be disconnected from other equipment. The negative cable must always be disconnected from the battery before disconnecting the positive cable. The ground wire of the welder shall be positioned as close as possible to the place of the welding. The cables on the welding unit shall never be placed near the electrical wires of the control system.

2.1.1. Construction regulations



CAUTION

The vehicle must be equipped with an emergency stop which disconnects the supply voltage to the control system's electrical units. The emergency stop must be easily accessible to the operator. The machine must be built if possible, so that the supply voltage to the control system's electrical units is disconnected when the operator leaves the operator's station.

2.1.2. Safety during installation



CAUTION

Incorrectly positioned or mounted cabling can be influenced by radio signals which can interfere with the functions of the system.

2.1.3. Safety during start-up



WARNING

The machine's engine must not be started before the control system is mounted and its electrical functions have been verified.

Ensure that no one is in front, behind or nearby the machine when first starting up the machine.

Follow the instructions for function control in the Start-up section.

2.1.4. Safety during maintenance and fault diagnosis



CAUTION

Ensure that the following requirements are fulfilled before any work is carried out on the hydraulics control electronics.

- The machine cannot start moving.
 - Functions are positioned safely.
 - The machine is turned off.
 - The hydraulic system is relieved from any pressure.
 - Supply voltage to the control electronics is disconnected.
-

3. Understanding the VMM0604

The Vansco Multiplexing Module (VMM) 0604 (shown in Figure 1) is a software-programmable, multiplexing, input/output controller that monitors dedicated and general-purpose inputs, and controls solid-state-switch outputs.

The VMM modules can be configured to meet many system requirements through I/O configuration options and ladder logic software.

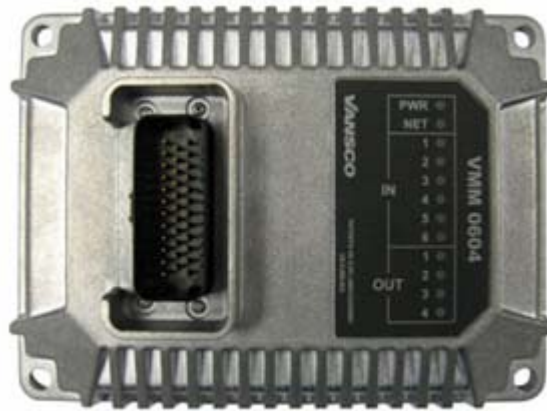

Figure 1: VMM0604

The VMM0604 is designed to communicate through a J1939-based Controller Area Network (CAN). Custom CAN messaging can be created in software, and the VMM0604 can be used in any CAN 2.0B application.

The VMM0604 is controlled by Ladder Logic software.

- You can write the software in ladder logic using the Vansco Multiplex Module Software (VMMS) tool. Contact your Parker Vansco Account Representative for more details about the VMMS.

The VMM0604 has many features, as follows:

- The VMM0604 can monitor up to 12 inputs:
 - 6 general purpose inputs (can be used as digital, analog, or frequency).
 - 5 digital inputs (active low inputs used for addressing).
 - 1 power control input.
- The VMM0604 has 8 outputs, rated at 3 A maximum current:
 - 4 high-side outputs.
 - 4 low-side outputs (these outputs monitor current, and can be used for current feedback if a high-side output is used for Pulse Width Modulation (PWM) control).
- The VMM0604 has one 35-pin Ampseal connector that is used to interface with the inputs, outputs, and CAN.

Vansco Multiplexing Module (VMM) 0604

9





- The VMM0604 has 12 diagnostic LEDs that are used to indicate the state and fault status of inputs, outputs, power, and CAN.
- The VMM0604 can detect and log the following faults on the outputs:
 - o Short-circuit
 - o Over-current
 - o Open load
 - o Short-to-battery
 - o Short-to-ground







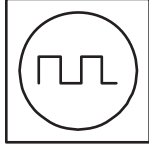
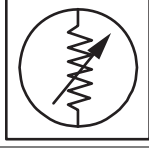
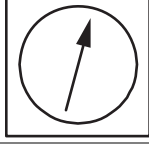
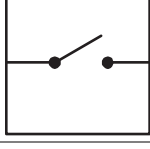

4. How to Use this Manual

This manual describes the hardware components of the VMM0604, but does not explain how to write or configure the software. For more information about software, refer to the appropriate software manual, or contact your Parker Vansco Account Representative.

4.1. Diagram Conventions

There are many connection diagrams found throughout this manual. The following table provides meanings for the different symbols used in those diagrams:

| Symbol | Meaning |
|---|--------------------|
|  | General input |
|  | General output |
|  | Frequency input |
|  | Analog input |
|  | Frequency sensor |
|  | Pulse sensor |
|  | Resistive sensor |
|  | General sensor |
|  | Application switch |

| Symbol | Meaning |
|--|--------------------|
|  | Load |
|  | Pull-down resistor |
|  | Pull-up resistor |
|  | Battery |
|  | Fuse |
|  | Resistor |
|  | Ground |
|  | Chassis ground |

5. Quick Start

This section provides step-by-step instructions on how to connect the VMM0604 to a development system, install the required software tools, and download ladder logic application software.

5.1. Overview

The following is a high-level overview of the steps involved with this section:

1. Gather the **required materials**.
2. Install the required **software tools** provided by Parker Vansco.
3. Connect the VMM0604 to a **development system** (desktop) and power it up.
4. Download ladder logic **application software**.

5.2. Gather Required Materials

The following materials are required for the procedures in this section:

- A **VMM0604**
- A **personal computer** (PC)
- A **controller I/O board**
- A **controller I/O harness** (connects the VMM0604 to the controller I/O board)
- An **evaluation kit power harness** (connects the controller I/O board to the power supply)
- A **Data Link Adapter (DLA) kit** (comes with cables needed for connecting the DLA to your PC and to the rest of the system)
- A **desktop power supply** compatible with the VMM0604 and controller I/O board loads (a 12 VDC, 3 A fixed voltage supply is generally suitable, unless driving more significant loads)
- A **procurement drawing** for the version of VMM0604 you are using, that represents the configuration options for your variant of the product.
- **Software tools** and files required for programming and downloading software for the VMM0604.



NOTICE

With the exception of the PC and desktop power supply, all materials and software are available from Parker Vansco. Please consult your Parker Vansco Account Representative for specific details and pricing information.

5.3. Install the Required Software Tools

Before you start using the VMM0604, you must install the software tools onto your PC.

The VMM0604 requires the following software tools:

- **Data Link Adaptor (DLA) drivers:** The DLA acts as the interface between the PC and the VMM0604. Before using the DLA, you must install the DLA drivers.
- **Parker Vansco Software Tools:** Parker Vansco provides the VMMS software tool to create and download software for the VMM0604. Contact your Parker Vansco Account Representative, or visit the Parker website to get further information on how obtain a product key.

5.3.1. Install the Data Link Adaptor (DLA) Driver Software

A Data Link Adaptor (DLA) is needed when connecting the VMM0604 in a development system.

The Parker Vansco DLA requires drivers that you must install on your PC.



NOTICE

Parker Vansco provides the latest DLA software releases through its web site. Please contact your Parker Vansco Account Representative for details on how to download the latest DLA driver software.

To install the Parker Vansco DLA drivers

1. **Download** the driver, run the extracted file and follow the *Install Wizard*.
2. Connect the **USB DLA** to a USB port on your PC.
The *Found New Hardware* screen opens.
3. Select **Install the software automatically (Recommended)**, and then click **Next**.
4. Click **Finish**.

The USB DLA is now recognized and ready to be used. See the Vansco DLA kit user manual for more detailed instructions.

5.4. Connect the VMM0604 to a Development System

It is a good idea to connect the VMM0604 to a development system (PC, Controller I/O Board, power source, and DLA) to verify your ladder logic application. The development system is an ideal environment for creating and downloading ladder logic software applications.

The following is an overall block diagram of how to connect the VMM0604 in a development system:

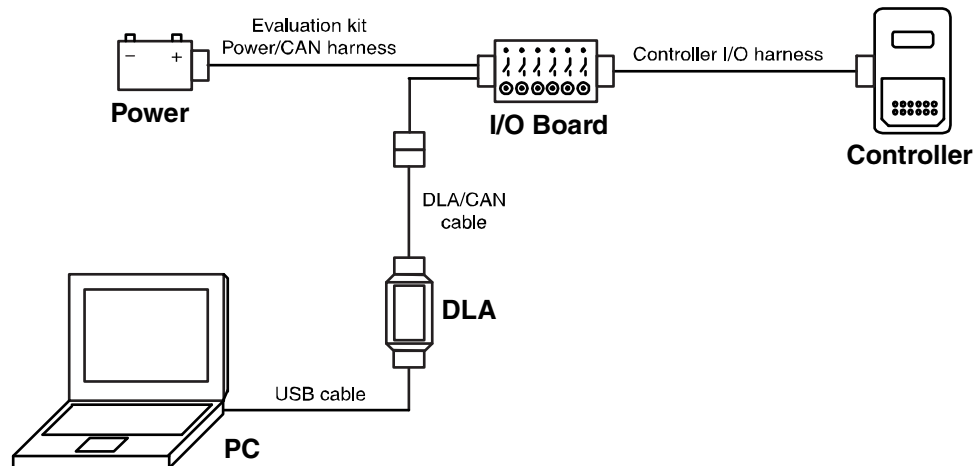

Figure 2: Development system connection

To connect the VMM0604 in a development system, do the following:



NOTICE

Before connecting anything in the development system, ensure the power supply is set to a voltage that is less than 32 VDC.

1. Connect the **Controller I/O harness** to the VMM0604 connectors.
2. Connect the **Controller I/O harness** to the controller I/O board connectors.
3. Connect the **evaluation kit power/CAN harness** to the controller I/O board's JP3 connector.
4. Do *not* connect the **power wire** (RED) from the evaluation kit power/CAN harness to the power supply (+) terminal at this time.
5. Connect the **ground wire** (BLACK) from the evaluation kit power/CAN harness to the power supply (-) terminal.
6. Connect the **CAN connector** from the evaluation kit power/CAN harness to the corresponding mating connector and harness on the DLA.
7. Connect the **DLA** to a personal computer via the USB port.

**NOTICE**

You must install the DLA drivers before connecting the DLA to the PC.

5.4.1. Power Up the Development System

Once the VMM0604 is connected in a development system, you need to power it up.

To power up the VMM0604, do the following:

1. Ensure all **controller I/O board digital inputs, jumpers, and dip switches** are properly configured for the VMM0604. Refer to the *Controller I/O Board Reference Manual* for further details.
2. Connect the **power wire** (red) from the evaluation kit power/CAN harness to the power supply (+), and turn the power supply **on**.
3. Turn **on** the controller I/O board switch that corresponds with the power control input on the VMM0604 (refer to the *Controller I/O Board Reference Manual* for details).

The power LED on the VMM0604 lights up.

**INFORMATION**

If the power LED does not light-up and you are unsure if a power control input is set on the VMM0604, try switching all the inputs on the controller I/O board to high, and then to low. If you continue to have problems, consult the Troubleshooting/FAQ section in the *Controller I/O Board Reference Manual* for help.

5.5. Create and Download Ladder Logic Software Applications

Software applications can be created and downloaded to the VMM0604.

The software applications for the VMM0604 can be created with the Vansco Multiplexing Module Software (VMMS) tool, using ladder logic.

Consult your Parker Vansco Account Representative for information about your software programming options.

6. Inputs

The VMM0604 has two main types of inputs, as follows:

- General purpose inputs (can be used as digital, analog, or frequency)
- Digital inputs



NOTICE

Do not connect inputs directly to unprotected inductive loads such as solenoids or relay coils, because they can produce high voltage spikes that may damage the VMM0604. If an inductive load must be connected to an input, use a protective diode or transorb.

6.1. General Purpose Inputs

The VMM0604 has 6 general purpose inputs that can be configured either as analog, digital, or frequency (ADF) through software, as follows:

- INPUT1_ADF through INPUT6_ADF

The following table provides the voltage ranges for the VMM0604 general purpose inputs:

Table 1: General Purpose Input Voltage Ranges

| Max Input Voltage | DC Freq Low Min | DC Freq High Max | AC Freq Min | Analog Resolution | Very Weak Pull-Down |
|-------------------|-----------------|------------------|-------------|-------------------|---------------------|
| 0.60 V | 0.16 V | 0.40 V | 250 mVpp | 0.59 mV | No |
| 0.75 V | 0.20 V | 0.50 V | 250 mVpp | 0.73 mV | No |
| 1.50 V | 0.40 V | 1.00 V | 250 mVpp | 1.47 mV | No |
| 3.00 V | 0.80 V | 2.00 V | 250 mVpp | 2.93 mV | No |
| 3.11 V | 0.83 V | 2.08 V | 250 mVpp | 3.05 mV | Yes |
| 3.89 V | 1.04 V | 2.59 V | 250 mVpp | 3.80 mV | Yes |
| 4.05 V | 1.08 V | 2.70 V | 250 mVpp | 3.96 mV | Yes |
| 5.07 V | 1.35 V | 3.38 V | 250 mVpp | 4.96 mV | Yes |
| 6.57 V | 1.75 V | 4.38 V | 250 mVpp | 6.41 mV | Yes |
| 7.80 V | 2.08 V | 5.19 V | 250 mVpp | 7.61 mV | Yes |
| 8.21 V | 2.19 V | 5.48 V | 250 mVpp | 8.04 mV | Yes |
| 10.14 V | 2.70 V | 6.76 V | 250 mVpp | 9.91 mV | Yes |
| 15.59 V | 4.17 V | 10.42 V | 250 mVpp | 15.28 mV | Yes |
| 16.44 V | 4.40 V | 10.99 V | 250 mVpp | 16.11 mV | Yes |
| 20.29 V | 5.41 V | 13.51 V | 250 mVpp | 19.81 mV | Yes |
| 32.88 V | 8.79 V | 21.98 V | 250 mVpp | 32.23 mV | Yes |

Vansco Multiplexing Module (VMM) 0604

17

6.1.1. General Purpose Used as Programmable Digital Input

Digital inputs are typically used for electrical signals that are either on or off.

The following general purpose inputs can be used as digital inputs:

- INPUT1_ADF to INPUT6_ADF



INFORMATION

There are 6 other digital inputs in addition to these inputs (refer to *Digital Inputs* on page 28 for more details).

6.1.1.1. Digital Input Capabilities

The following table provides specifications for the VMM0604's standard digital inputs:

Table 2: Digital Input Specifications

| Item | Min | Nom | Max | Unit |
|---|-------|-------|-------|----------|
| Input voltage range | 0 | - | 32 | V |
| Pull-up / down resistance | 3.1 k | - | 3.5 k | Ω |
| Minimum negative going threshold | 1.3 | - | - | V |
| Maximum positive going threshold | - | - | 3.4 | V |
| Cutoff frequency (<i>hardware</i>) ¹ | - | 12 | - | kHz |
| De-bounce time (<i>software</i>) ² | 25 | - | 50 | ms |
| Over-voltage | - | - | 36 | V |
| Wetting current @ 12 V | 3.43 | - | 3.87 | mA |
| Amplifier <i>gain</i> ³ | - | 0.592 | - | V/V |
| Leakage current sleep mode - pin @ 12 V | - | - | 4.1 | mA |

6.1.1.2. Digital Input Configuration Options

Digital inputs can be programmed as either active high or active low, and they can have a pull-up or pull-down resistance of **3.3 k Ω** .

- **If the input is configured as active high**, an internal **pull-down** resistor will be used, and the input will be active when it is switched to battery voltage.

¹ Assumes there is a zero ohm source impedance from driving source. The actual cutoff in the application will be partially determined from the source impedance and VMM input capacitance.

² De-bounce time is based on a sampling rate of 40 Hz.

³ Amplifier gain on digital inputs is only adjustable in "black box" software. It is only pre-set to the value in the table if using ladder logic.

- **If the input is configured as active low**, an internal **pull-up** resistor will be used, and the input will be active when it is switched to ground.

6.1.1.3. Digital Input Installation Connections

You must be aware of the following when connecting digital inputs:

A digital input is typically connected to a switch that is either open or closed.

- **When the switch is open**, the pull-down resistor will ensure no voltage exists on the input signal, which will be interpreted by the VMM0604 as inactive.
- **When the switch is closed**, the input is connected to battery voltage, which will be interpreted by the VMM0604 as active.

Since the input is active high

- It must be connected to battery power to ensure there is a battery connection when the state of the input changes.
- The power provided to the digital switch connected to the input must be provided through a fuse in the wire harness.

The following shows a typical active high digital input connection:

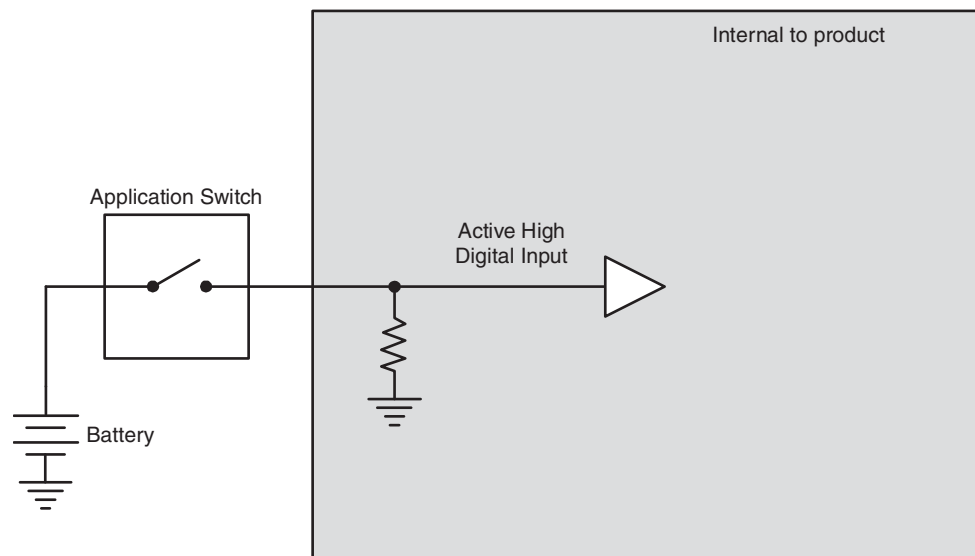

Figure 3: Active high digital input

6.1.2. General Purpose Used as Analog Input

Analog inputs are typically used to read electrical signals that span a voltage range.

The following general purpose inputs can be used as analog inputs:

- INPUT1_ADF to INPUT6_ADF

6.1.2.1. Analog Input Capabilities

The following table provides specifications for the VMM0604 analog inputs:

Table 3: Analog Input Specifications

| Item | Min | Nom | Max | Unit |
|---|-------|---------------|-------|----------|
| Input voltage range | 0 | - | 32 | V |
| Over-voltage | - | - | 36 | V |
| Pull-up / down resistance | 3.1 k | - | 3.5 k | Ω |
| Input resistance – pull-up/pull-down disabled | 74 k | - | - | Ω |
| Input capacitance | 9 | 10 | 11 | nF |
| Cutoff frequency (<i>hardware</i>) ⁴ | - | 12 | - | kHz |
| Accuracy | - | - | 3 | % |
| <i>Resolution</i> ⁵ | 4.375 | - | 4.422 | mV |
| Analog gain | - | Program-mable | - | V/V |
| Reference voltage | 2.984 | 3.0 | 3.016 | V |
| Leakage current sleep mode - pin @ 12 V | - | - | 4.1 | mA |

6.1.2.2. Analog Input Configuration Options

If one of the VMM0604's general purpose inputs is configured as an analog input, the input will be converted by the microprocessor using a 10-bit analog to digital converter (ADC) that is referenced to **3.0 V**.

There are **16 programmable gain and attenuation factors** that allow you to optimize the voltage resolution for each analog input, by converting the maximum external voltage signal expected on an analog input to as close to 3.0 V as possible.



INFORMATION

The attenuation and gain columns in the table represent the state of the two attenuation transistors and two gain transistors on each analog input circuit.

The pull-up or pull-down for analog inputs can be enabled or disabled; however, both pull-up and pull-down cannot be enabled at the same time. The pull-up and pull-down resistance is 3.3 k Ω .

⁴ Assumes there is a zero ohm impedance from driving source. The actual cutoff in the application will be partially determined from the source impedance and VMM input capacitance.

⁵ 10 bit ADC at worst case reference voltage, with 0.5 LSB fault.

Table 4: Gain and Attenuation Factors

| Amp Gain | Max Voltage | Attenuation 1 | Attenuation 2 | Gain 1 | Gain 2 |
|----------|-------------|---------------|---------------|--------|--------|
| 5.008 | 0.599 | OFF | OFF | ON | ON |
| 4.005 | 0.749 | OFF | OFF | OFF | ON |
| 2.000 | 1.5 | OFF | OFF | ON | OFF |
| 1 | 3 | OFF | OFF | OFF | OFF |
| 0.963 | 3.115 | ON | OFF | ON | ON |
| 0.771 | 3.893 | ON | OFF | OFF | ON |
| 0.740 | 4.053 | OFF | ON | ON | ON |
| 0.592 | 5.065 | OFF | ON | OFF | ON |
| 0.457 | 6.569 | ON | ON | ON | ON |
| 0.385 | 7.796 | ON | OFF | ON | OFF |
| 0.365 | 8.209 | ON | ON | OFF | ON |
| 0.296 | 10.144 | OFF | ON | ON | OFF |
| 0.192 | 15.591 | ON | OFF | OFF | OFF |
| 0.182 | 16.440 | ON | ON | ON | OFF |
| 0.148 | 20.286 | OFF | ON | OFF | OFF |
| 0.091 | 32.877 | ON | ON | OFF | OFF |

6.1.2.3. Analog Input Installation Connections

When connecting analog inputs, there are two issues you must be aware of: system noise and ground shift.

System Noise

Analog inputs are more susceptible to system noise than digital inputs. Too much system noise can create inaccurate analog input readings.

To reduce system noise

- Use the shortest possible wires when connecting analog inputs to sensors, to prevent noise pickup on the sensors.

The following shows how to connect analog inputs to reduce system noise:

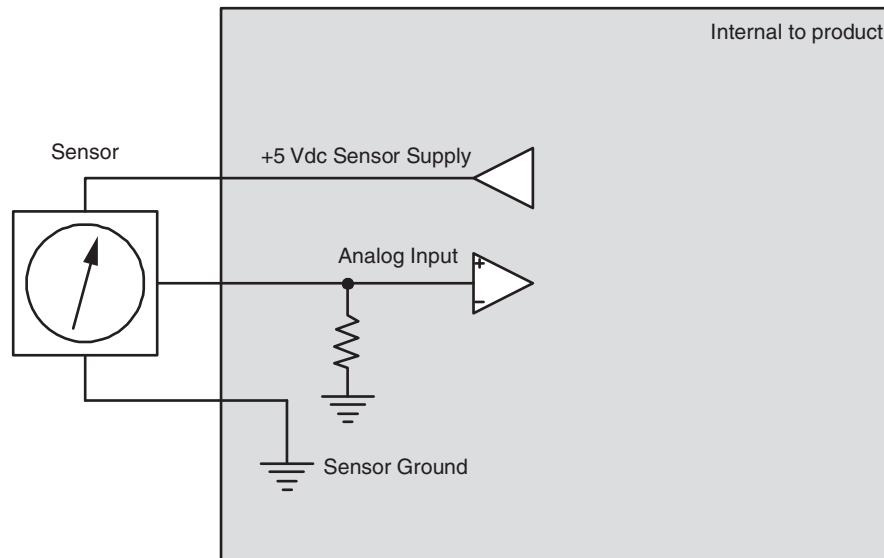

Figure 4: Analog input system noise connection

Ground Shift

The accuracy of analog inputs can be affected by ground shift. Ground shift refers to the difference between the VMM0604 system ground input voltage (system ground inputs are called **GND**), and the sensor ground voltage.

To reduce ground shift

- Dedicate one of the four system ground inputs (**GND**) to sensors that have dedicated ground wires, and connect all sensor grounds to this system ground input.
- Splice the other three system ground inputs together in the vehicle harness (close to the connector), to provide a better ground for the noisier low-side outputs and digital circuits.
- Ensure the sensor's ground connection is close to the system ground connections. This will help ensure the signal remains within the digital activation range of the input.



INFORMATION

The VMM0604 system ground inputs are rated for low-current signals, which ensures the sensor's ground is very close in voltage potential to the system ground.



INFORMATION

Sensors that don't have a dedicated ground wire are typically grounded to the vehicle chassis through the sensor's body.

The following shows how to address ground shift with sensors that have dedicated ground wires:

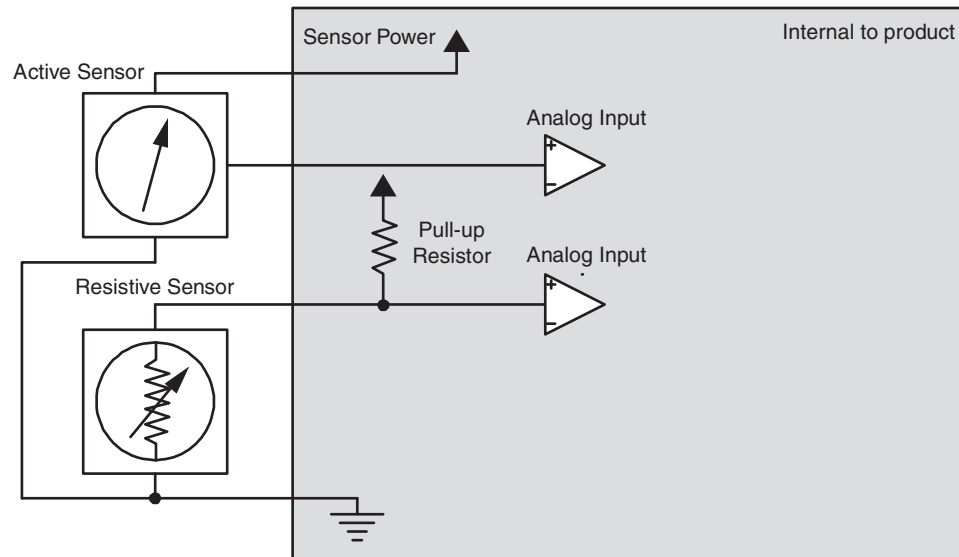

Figure 5: Analog input ground shift connection for sensors that have dedicated ground wires

6.1.3. General Purpose Used as AC-Coupled Frequency Input

The following general purpose inputs can be used as AC-coupled frequency inputs:

- INPUT1_ADF and INPUT2_ADF

6.1.3.1. AC-Coupled Frequency Input Capabilities

AC-coupled frequency inputs provide AC-coupling, which allows you to read the frequency of external signals that have either large DC offsets, or no ground reference. These inputs are ideal for use with variable reluctance and inductive pickup sensors.



INFORMATION

Quadrature and pulse counting is possible; however, we recommend to not use these functions with AC-coupled frequency inputs.

The following table provides specifications for the VMM0604 general purpose inputs when used as AC-coupled frequency inputs:

Table 5: AC-Coupled Frequency Input Specifications

| Item | Min | Nom | Max | Unit |
|---|-------|-----|-------|------|
| Input voltage <i>range</i> ⁶ | -90 | - | 90 | V |
| Pull-up / down resistance | 3.1 k | - | 3.5 k | Ω |

⁶ Input voltage range assumes that the inductive pickup will increase in voltage as flywheel speed increases. Analog input pull-up configuration options must be selected accordingly to prevent damage on those components at these voltage extremes.

| Item | Min | Nom | Max | Unit |
|---|------|------|-------|------|
| Input resistance – pull-up/pull-down disabled | 74 k | - | - | Ω |
| Input capacitance | 9 | 10 | 11 | nF |
| AC-coupling capacitance | - | 0.3 | - | uF |
| Frequency range @ 0.25 Vp-p | 5 | - | 10000 | Hz |
| Accuracy | - | - | 5 | % |
| Resolution | 0.1 | - | - | Hz |
| Switching threshold <u>voltage</u> ⁷ | - | 1.65 | - | V |
| Leakage current sleep mode - pin @ 12 V | - | - | 4.1 | mA |

6.1.3.2. AC-Coupled Frequency Input Configuration Options

AC-coupled frequency inputs have 16 programmable gain and attenuation factors.

The pull-up or pull-down for AC-coupled frequency inputs can be enabled or disabled; however, both pull-up and pull-down cannot be enabled at the same time. The pull-up and pull-down resistance is **3.3 kΩ**.

6.1.3.3. AC-Coupled Frequency Input Installation Connections

When connecting AC-coupled frequency inputs, there are two issues you must be aware of: system noise and ground shift.

System Noise

AC-coupled frequency inputs are more susceptible to system noise than digital inputs.

To reduce system noise

- Connect AC-coupled frequency inputs to sensors with significant DC offset.
- Use the shortest possible wires when connecting AC-coupled frequency inputs to sensors to prevent noise pickup on the sensors.

Ground Shift

Ground shift affects the accuracy of AC-coupled frequency inputs. Ground shift refers to the difference between the system ground input (GND) voltage, and the sensor ground voltage.

To reduce ground shift

- Dedicate one of the 4 system ground inputs (GND) to sensors that have dedicated ground wires, and connect all sensor grounds to this system ground input.

⁷ The switching threshold on AC-coupled inputs is not programmable, and is set internally to ensure proper conversion of the input signal through a comparator circuit. The value given in the table is not a physical value on the product's input pin.

- Splice the other system ground inputs together in the vehicle harness (close to the connector), to provide a better ground for the noisier low-side outputs and digital circuits.
- Ensure the sensor's ground connection is close to the system ground connections. This will help ensure the signal remains within the digital activation range of the input.



INFORMATION

The VMM0604 system ground inputs are rated for low-current signals, which ensures the sensor's ground is very close in voltage potential to the system ground.



INFORMATION

Sensors that don't have a dedicated ground wire are typically grounded to the vehicle chassis through the sensor's body.

The following shows a typical AC-coupled frequency input connection:

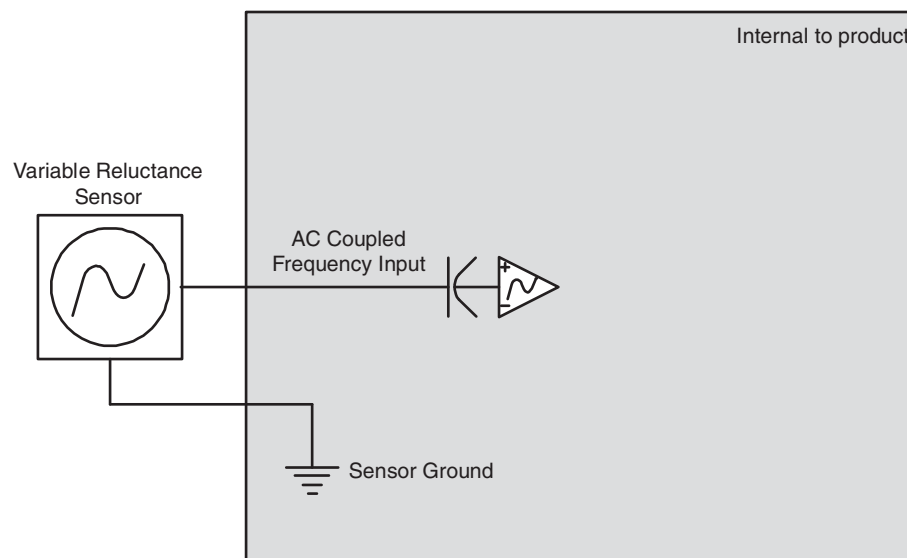

Figure 6: AC-coupled frequency input installation connections

6.1.4. General Purpose Used as DC-Coupled Frequency Input

The following general purpose inputs can be used as DC-coupled frequency inputs:

- INPUT3_ADF to INPUT6_ADF

6.1.4.1. DC-Coupled Frequency Input Capabilities

DC-coupled frequency inputs allow you to read the frequency of external signals that have a ground reference and no DC offset. These inputs are ideal for use with hall-effect type sensors.



INFORMATION

Quadrature and pulse counting is possible with DC-coupled frequency inputs.

The following table provides specifications for the VMM0604 general purpose inputs when used as DC-coupled frequency inputs:

Table 6: DC-Coupled Frequency Input Specifications

| Item | Min | Nom | Max | Unit |
|---|-------|---------------|-------|----------|
| Input voltage range | 0 | - | 32 | V |
| Pull-up / down resistance | 3.1 k | - | 3.5 k | Ω |
| Input resistance – pull-up/pull-down disabled | 74 k | - | - | Ω |
| Input capacitance | 9 | 10 | 11 | nF |
| Frequency range @ 0.25 Vp-p | 1 | - | 10000 | Hz |
| Accuracy | - | - | 5 | % |
| Resolution | 0.1 | - | - | Hz |
| Switching threshold voltage (software) | - | Program-mable | - | V |
| Leakage current sleep mode - pin @ 12 V | - | - | 4.1 | mA |

6.1.4.2. DC-Coupled Frequency Input Configuration Options

DC-coupled frequency inputs have 16 programmable gain and attenuation factors, as indicated in Table 4.

The pull-up or pull-down for DC-coupled frequency inputs can be enabled or disabled; however, both pull-up and pull-down cannot be enabled at the same time. The pull-up and pull-down resistance is **3.3 k Ω** .

6.1.4.3. DC-Coupled Frequency Input Installation Connections

When connecting DC-coupled frequency inputs, there are two issues you must be aware of: system noise and ground shift.

System Noise

DC-coupled frequency inputs are more susceptible to system noise than digital inputs.

To reduce system noise

- Connect DC-coupled frequency inputs to sensors that produce signals with no DC offset.
- Use the shortest possible wires when connecting DC-coupled frequency inputs to sensors to prevent noise pickup on the sensors.

Ground Shift

Ground shift affects the accuracy of DC-coupled frequency inputs. Ground shift refers to the difference between the system ground input (GND) voltage, and the sensor ground voltage.

To reduce ground shift

- Dedicate one of the 4 system ground inputs (called GND) to sensors that have dedicated ground wires, and connect all sensor grounds to this system ground input.
- Splice the other system ground inputs together in the vehicle harness (close to the connector), to provide a better ground for the noisier low-side outputs and digital circuits.
- Ensure the sensor's ground connection is close to the system ground connections. This will help ensure the signal remains within the digital activation range of the input.



INFORMATION

The VMM0604 system ground inputs are rated for low-current signals, which ensures the sensor's ground is very close in voltage potential to the system ground.



INFORMATION

Sensors that don't have a dedicated ground wire are typically grounded to the vehicle chassis through the sensor's body.

The following shows a typical DC-coupled frequency input connection:

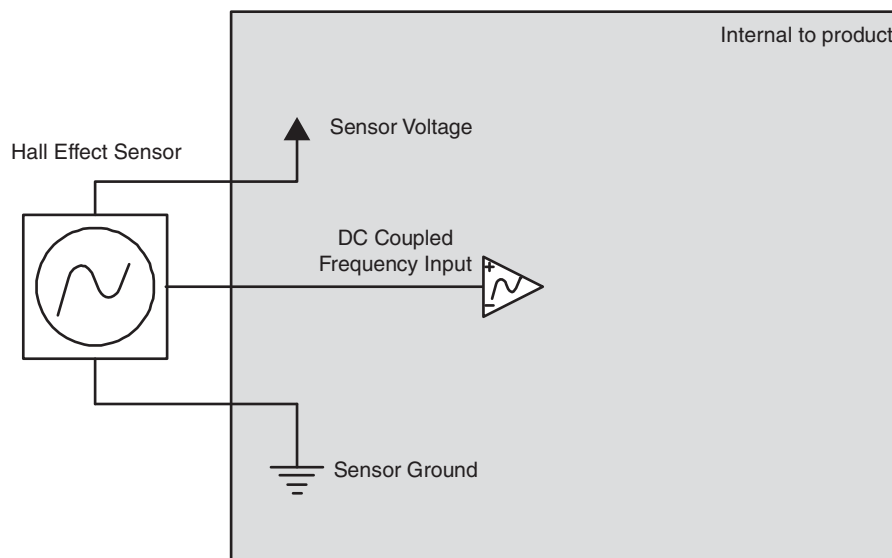

Figure 7: DC-coupled frequency input installation connections

6.2. Digital Inputs

Digital inputs are typically used with electrical signals and switches that are either on or off.

There are three types of digital inputs in the VMM0604:

- Programmable Digital Inputs
- Power Control Digital Inputs
- Addressing Digital Inputs

6.2.1. Programmable Digital Inputs

The general purpose inputs can be used as programmable digital inputs. Refer to *General Purpose Used as Programmable Digital Input* on page 18 for more details.

6.2.2. Power Control Digital Input

The VMM0604 has 1 active high digital input dedicated to power control that is used for waking up (turning on) the product, called `POWER_CONTROL`.

6.2.2.1. Power Control Digital Input Capabilities

The VMM0604 has an active high power control digital input that must be activated to power up the VMM0604.



INFORMATION

The power control digital input voltage must be greater than 4.0 V before it is considered an active high input.

The power control digital input wakes-up the VMM0604 when switched high to a voltage of 4.0 V or greater, and puts the VMM0604 in sleep mode (turns it off) when switched low to a voltage less than 1.7 V. The VMM0604 will also go into sleep mode when an open circuit condition occurs on the power control digital input.

The following table provides specifications for the power control digital input:

Table 7: Power Control Digital Input Specifications

| Item | Min | Nom | Max | Unit |
|---|-------|-----|-------|----------|
| Input voltage range | 0 | - | 32 | V |
| Pull-down resistance | 3.1 k | - | 3.5 k | Ω |
| Minimum negative going threshold | 2.14 | - | - | V |
| Maximum positive going threshold | - | - | 4.0 | V |
| Power-up threshold | - | 1.7 | - | V |
| Cutoff frequency (<i>hardware</i>) ⁸ | - | 85 | - | Hz |
| De-bounce time (<i>software</i>) ⁹ | 25 | - | 50 | ms |

⁸ Assumes there is a zero ohm source impedance from driving source. The actual cutoff in the application will be partially determined from the source impedance and VMM input capacitance.

⁹ De-bounce time is based on a sampling rate of 40 Hz.

| Item | Min | Nom | Max | Unit |
|---|------|-----|------|------|
| Over-voltage | - | - | 36 | V |
| Wetting current @ 12 V | 3.43 | - | 3.87 | mA |
| Leakage current sleep mode - battery @ 12 V | - | - | 200 | uA |
| Leakage current when power control active - battery @ 12 V | - | - | 4 | mA |

6.2.2.2. Power Control Digital Input Installation Connections

You must be aware of the following when connecting the power control digital input:

- The power control digital input is usually connected to the vehicle ignition, but it can be connected to any power source in a system.
- To protect the harness that connects the VMM0604 to the ignition, place a fuse of **200 mA** or higher in the circuit that feeds the VMM0604.
- If your VMM0604 must always be powered, the power control digital input can be directly connected to a fused battery power input (called VBATT), which will provide constant power.
- When battery power (VBATT) is connected, and the power control digital input is inactive, the VMM0604 will go into sleep mode.

The following shows a typical power control digital input connection:

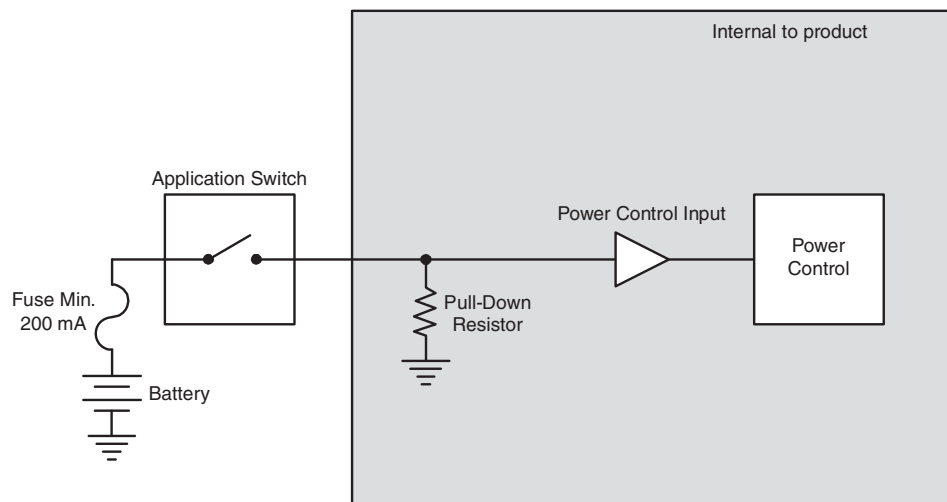

Figure 8: Power control digital input installation connections

6.2.3. Addressing Digital Inputs

The VMM0604 has 5 active low digital inputs that are used for module addressing on the CAN network:

- ADDR1 to ADDR5

Vansco Multiplexing Module (VMM) 0604

29

6.2.3.1. Addressing Digital Input Capabilities

The following table provides specifications for the VMM0604 addressing digital inputs:

Table 8: Addressing Digital Input Specifications

| Item | Min | Nom | Max | Unit |
|--|-------|-----|------|------|
| Input voltage range | 0 | - | 32 | V |
| Pull-up resistance | 9.8 k | - | 10.2 | kΩ |
| Minimum negative going threshold | 0.9 | - | - | V |
| Maximum positive going threshold | - | - | 2.15 | V |
| Cutoff frequency (hardware) | - | 80 | - | Hz |
| De-bounce <i>time</i> ¹⁰ | - | - | - | ms |
| Over-voltage | - | - | 36 | V |
| Wetting current | 316 | - | 343 | uA |
| Leakage current sleep mode - pin grounded or floating | - | 0 | - | A |

6.2.3.2. Addressing Digital Input Connections

These inputs are used to set the system address on the module such that it is unique among all other modules in the system. The maximum allowable addresses in a VMM system is 31.

The inputs are all active low inputs with internal pull-up resistors. The inputs are pulsed to ensure that a floating pin is read as inactive by the module.

The addressing arrangement is shown in the following table, which shows the required inputs that need to be active (connected to ground), and those that are floating.

Table 9: VMM system addressing (active=1, floating=0)

| Address Inputs | | | | | |
|----------------|---|---|---|---|-------------|
| 5 | 4 | 3 | 2 | 1 | VMM address |
| 0 | 0 | 0 | 0 | 0 | VMM1 |
| 0 | 0 | 0 | 0 | 1 | VMM2 |
| 0 | 0 | 0 | 1 | 0 | VMM3 |
| 0 | 0 | 0 | 1 | 1 | VMM4 |
| 0 | 0 | 1 | 0 | 0 | VMM5 |
| | | | | | |
| 1 | 1 | 1 | 1 | 0 | VMM31 |

¹⁰ De-bounce time for address inputs is based on hardware cutoff frequency. The software reads the address in succession during power-up until it receives two consecutive results that are the same. The time between readings is in the microsecond range so there is technically no software de-bounce on these inputs.

**NOTICE**

Address 32 is reserved and therefore may not be used in a system design.

The following shows a typical active low digital input addressing connection:

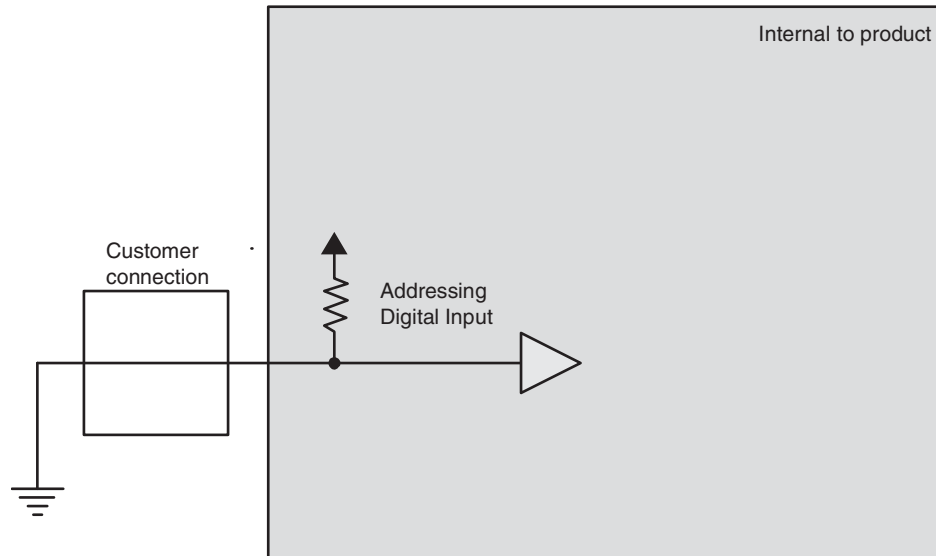

Figure 9: Addressing digital input connections

7. Outputs

The VMM0604 has 8 solid-state FET technology outputs designed for low to medium current and high inrush inductive load switching. Output currents can range up to 3.0 A.

The VMM0604 has 2 types of outputs:

- High-side outputs
- Low-side outputs with current sense



INFORMATION

A high-side and a low-side output can be used to create a half-bridge. An H-bridge output can be created from 2 half-bridges, allowing 2 full H-bridge outputs to be produced (refer to *Controlling a Linear Actuator* for an example of how to use an H-bridge).

7.1. VMM0604 High-Side Outputs

The VMM0604 has 4 high-side outputs:

- OUTPUT1_3A_HS to OUTPUT4_3A_HS

7.1.1. High-Side Output Capabilities

High-side outputs are used for switching voltages to loads using either a **pulse width modulated (PWM) signal**, or an **on/off signal**. They can also test for various fault conditions, which can be used for software diagnostics (refer to *High-Side Output Diagnostics and Fault Protection* on page 34 for more details).

All high-side outputs come with internal flyback diodes that provide protection when driving inductive loads.

- **When a high-side output is used as a PWM signal**, a pulsed output signal is provided by the VMM0604, where the percentage of time that the output is “on” vs. “off” is determined by the duty cycle of the signal, and the duty cycle is determined by the application software.
- **When a high-side output is used as an on/off signal**, the output provides battery voltage when in the “on” state (the application software is responsible for switching high-side outputs “on” and “off”).

The following table provides specifications for the VMM0604 high-side outputs:

Table 10: High-Side Output Specifications

| Item | Min | Nom | Max | Unit |
|---------------------------|-----|-----|-----|------|
| Operational voltage range | 6 | - | 32 | V |
| Over-voltage | - | - | 36 | V |

Vansco Multiplexing Module (VMM) 0604

32

| Item | Min | Nom | Max | Unit |
|--|-------|-----|-------|------------|
| Output current range | 0 | - | 3 | A |
| Load impedance @ 12 V | 4 | - | - | Ω |
| PWM frequency | 5 | - | 500 | Hz |
| PWM <u>resolution</u> ¹¹ | - | 0.1 | - | % |
| Flyback diode <u>current</u> ¹² | - | - | 1 | A |
| Short-circuit current limit (Tjunc = -40°C to +150°C) | 9 | 15 | 23 | A |
| Short-circuit trip time | - | 2 | - | ms |
| Thermal protection | - | 150 | - | °C |
| Digital feedback negative threshold | 1.5 | - | - | V |
| Digital feedback positive threshold | - | - | 3.58 | V |
| Digital feedback cutoff frequency | - | 26 | - | kHz |
| Open-load detection – max detectable load @ 12 V | - | - | 1.4 k | Ω |
| Open-load detection pull-up | 9.8 k | - | 10.2 | k Ω |
| Current sensing | - | No | - | - |
| Analog feedback | - | No | - | - |

7.1.2. High-Side Output Installation Connections

You must be aware of the following when connecting high-side outputs:

- High-side outputs are connected to an internal bus bar, which can be connected to a **+12 V** or **+24 V** battery. The bus bar is connected to logic power (VBATT), and both share the same connector pins.
- High-side outputs can provide switched battery power to any load type in a vehicle.
- High-side outputs can source up to **3.0 A**.
- High-side outputs have internal flyback diodes, which are needed when driving inductive loads (the flyback diodes absorb electrical energy when the load is turned off).



INFORMATION

Inductive loads will create an average current flow that moves out of the high-side output. When the output is on, the current flows through the output driver, and when the output is off, the current flows through the flyback diode. A duty cycle of 50% will produce the worst case average current flow through these two devices.

¹¹ This is the typical value. Actual value is dependent on the base frequency, since the counter used for this operation has a finite number of steps.

¹² This is an average current value, meaning a worst case PWM current of 2 A at 50% duty cycle is possible with inductive loads.



NOTICE

If large inductive loads are used, and the high-side output is providing a continuous PWM signal, then the PWM peak current must not be greater than the specified continuous current for the output (in continuous mode, the average current flow through the diode at 50% duty cycle is approximately equal to $\frac{1}{2}$ the peak current).

When connecting high-side outputs, ensure you follow these best practices:

- High-side outputs should not be connected to loads that will draw currents greater than the maximum peak current, or maximum continuous current.
- The grounds for the loads should be connected physically close to the VMM0604 power grounds.

The following shows a typical high-side output connection:

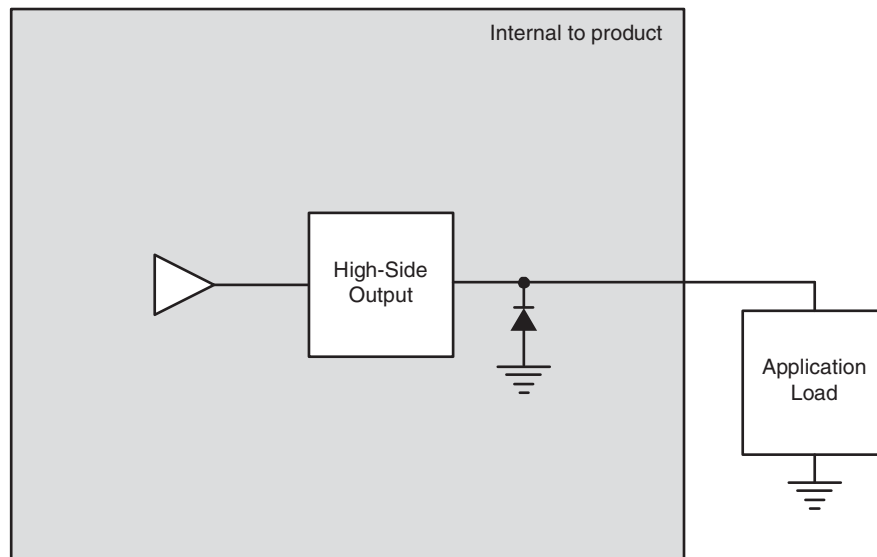

Figure 10: Typical high-side output installation connections

7.1.3. High-Side Output Diagnostics and Fault Protection

The VMM0604 high-side outputs have the ability to report many different fault conditions. They are protected against short-circuit and over-current, open load, and short-to-battery faults.



INFORMATION

The VMM0604 LEDs can be used to indicate output fault status through the application software.

7.1.3.1. Short Circuit

Short-circuit faults occur when a high-side output pin is shorted to ground. The output will turn off and retry as defined by the programmer.

7.1.3.2. Open Load

Open load faults occur when a low-side output pin is open circuit (not connected to a load). The use of this feature operates is defined by the programmer.

The low-side output circuit uses a small amount of current on the output pin to determine if an open load condition exists.



INFORMATION

Low-side outputs must be “on” to detect an open-load fault.

7.1.3.3. Short-to-Battery

Short-to-battery faults occur when a high-side output pin is connected to battery voltage.

The high-side output circuit uses voltage on the output pin to determine if a short-to-battery condition exists.



INFORMATION

High-side outputs must be “off” to detect a short-to-battery fault.

7.2. VMM0604 Low-Side Outputs with Current Sense

The VMM0604 has 4 low-side outputs:

- OUTPUT5_3A_LS to OUTPUT8_3A_LS

7.2.1. Low-Side Outputs with Current Sense Capabilities

Low-side outputs with current sense are used for switching grounds to loads using either a **pulse width modulated (PWM) signal**, or an **on/off signal**. They also have the ability to **sense current** that is provided to loads, through an amplifier circuit.

- **When a low-side output is used as a PWM signal**, a pulsed output signal is provided by the VMM0604, where the percentage of time that the output is “on” vs. “off” is determined by the duty cycle of the signal, and the duty cycle is determined by the application software.



INFORMATION

Current flow gets interrupted when using low-side outputs as a PWM signal, because the outputs are not “on” continuously. Therefore, current feedback control systems should use a high-side output for PWM signals, and a low-side output (turned on at 100%) for sensing current.

- **When low-side outputs are used as an on/off signal**, the output provides ground when in the “on” state (the application software is responsible for switching low-side outputs “on” and “off”).

- **When low-side outputs are used to sense current**, the application software will monitor the current flowing into the low-side output, and based on the amount of current, will turn the output either "on" or "off".
 - o The amplifier that measures the sensed current has an allowable voltage range of 0 V to 3 V. The application software will protect the circuit from an over-current or short-circuit event when the voltage from the amplifier reaches 2.9 V; therefore, the actual usable voltage range from the amplifier is only 0 V to 2.8 V.

The following table provides specifications for the VMM0604 low-side outputs:

Table 11: Low-Side Outputs with Current Sense Specifications

| Item | Min | Nom | Max | Unit |
|---|----------------|-------------------|-----------|--------------|
| Operational voltage range | 0 | - | 32 | V |
| Over-voltage | - | - | 36 | V |
| Output current range | 0 | - | 3 | A |
| Load impedance @ 12 V | - | 4 | - | Ω |
| PWM | - | No | - | - |
| Short-circuit protection | - | Yes | - | - |
| Thermal protection | - | No | - | - |
| Analog feedback gain (current sense) - programmable | 6.008 (0.6) | Program- mable | 10 (1) | V/V (V/A) |
| Analog feedback cutoff frequency @ min gain | - | 12 | - | Hz |
| Current sense resistance | 0.099 | - | .101 | Ω |
| Current sensing resolution - 0 to 3 A range | - | 5 | 14.5 | mA |
| Current sensing resolution - 0 to 2 A range | - | 3 | 8.7 | mA |
| Current sensing accuracy | - | - | 3.5 | % |
| Short-circuit trip time | - | - | 500 | us |
| Short-circuit current limit | - | 14 | - | A |
| Over-current trip point - 0 to 3 A range | - | 3.1 | - | A |
| Over-current trip point - 0 to 2 A range | - | 2.1 | - | A |
| Over-current trip time | - | 1 | - | s |
| Open-load detection | - | No | - | - |
| Digital feedback | - | No | - | - |

7.2.2. Low-Side Outputs with Current Sense Configuration Options

There are 2 programmable gain and attenuation factors that allow you to convert the maximum voltage expected on the low-side outputs to as close to **3.0 V** as possible (to optimize the voltage resolution).

Table 12: Gain and Attenuation for Low-Side Outputs with Current Sense

| Amp Gain | Max Current (A) | Attenuation 1 | Gain 1 |
|----------|-----------------|---------------|--------|
| 6.008 | 5 | ON | ON |
| 10 | 3 | OFF | OFF |

7.2.3. Low-Side Outputs with Current Sense Installation Connections

You must be aware of the following when connecting low-side outputs:

- Low-side outputs are connected to a common internal ground point that is connected to the battery ground (GND). Refer to *Logic and Output Power* for more details about the battery ground.
- Low-side outputs provide switched ground to any load type in a vehicle.
- Low-side outputs can sink up to **3.0 A**.
- When connecting a load to a low-side output, **ensure the load will not** drive currents greater than the maximum specified peak current, or maximum specified continuous current.

The following shows a typical low-side output connection:

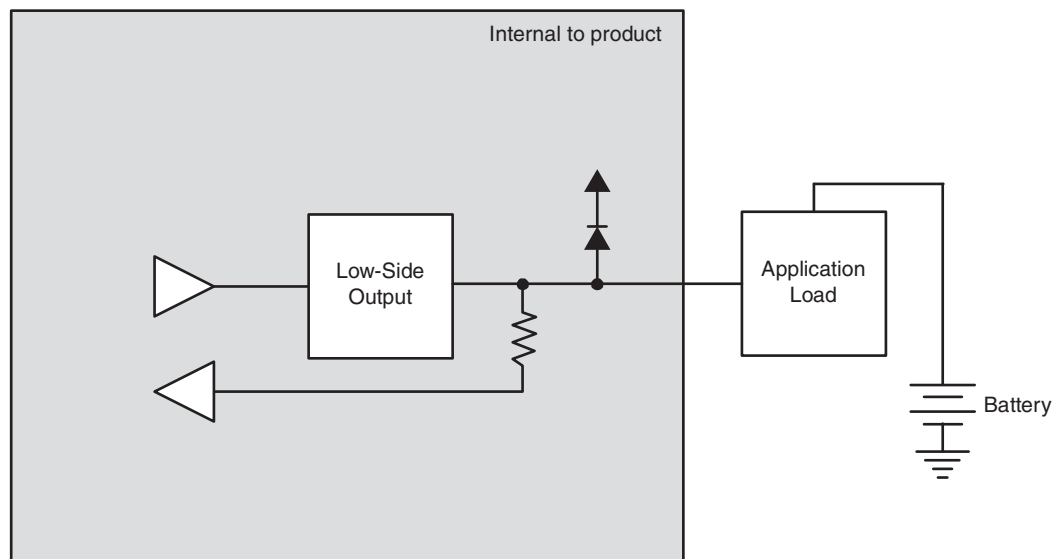

Figure 11: Low-side outputs with current sense installation connections

7.2.4. Low-Side Outputs with Diagnostics and Fault Protection

The VMM0604 low-side outputs have the ability to report many different fault conditions, and are protected against short-circuit, over-current, and short-to-ground faults.

Vansco Multiplexing Module (VMM) 0604



INFORMATION

The VMM0604 diagnostic LEDs indicate the output's status.

7.2.4.1. Short-Circuit

Short circuit faults occur when a low-side output pin is shorted to battery. The output will turn off and retry as defined by the programmer.

7.2.4.2. Over-Current

Over-current faults occur when a low-side output pin draws more current than the specified **over-current trip point**.

When an over-current fault is detected, the hardware automatically turns off the output.

The over-current trip time for low-side outputs is approximately **1 second**.



INFORMATION

The VMM0604 can be programmed in ladder logic to automatically reset an output from an over-current fault.

7.2.4.3. Short-to-Ground

Short-to-ground faults occur when a low-side output pin is connected to ground.

The low-side output circuit uses current on the output pin to determine if a short-to-ground condition exists.

8. VMM0604 Diagnostic LEDs

The VMM0604 has 12 red LEDs that are used to indicate the status of inputs, outputs, power and the Controller Area Network (CAN).

The following shows the VMM0604's LEDs as they appear on the product:

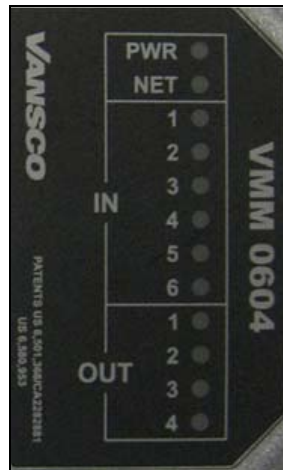

Figure 12: VMM0604 LEDs

8.1. Input LEDs

Input LEDs are used to indicate the status of inputs.

Input LEDs are labeled “IN” (1 to 6) on the VMM0604.

8.2. Output LEDs

Output LEDs are used to indicate the status of high-side outputs.

Output LEDs are labeled “OUT” (1 to 4) on the VMM0604.

8.3. Power LED

The power LED (labeled PWR) is used to indicate the status of power, software, and faults on the VMM0604.

8.4. Network LED

The network LED (labeled NET) is used to monitor the state of the CAN network.

9. Power

The VMM0604 is powered by the vehicle battery. The VMM0604 operates in a 12 V or 24 V system, and can operate from 6 V up to 32 V, with overvoltage protection at 36 V protection.

The VMM0604 has various pins on the connectors that are used for different types of power, as detailed in the following sections.

9.1. Logic and Output Power

The VMM0604 has **3 pins** dedicated to providing power for logic and outputs, called VBATT, and **4 pins** dedicated to grounding the VMM0604, called GND.



INFORMATION

The power and ground connections are paralleled over several pins to minimize voltage drops on higher current applications.

9.1.1. Logic and Output Power Capabilities

Logic power provides power to the logic circuit, which consists of the microprocessor, RAM, etc. The logic circuit can draw a maximum of **300 mA**.

Output power provides power to the output circuits through a battery or ground connection. Each output circuit can draw a maximum of **3 A**.

The following table provides specifications for the VMM0604 logic and output power:

Table 13: Logic and Output Power Specifications

| Item | Min | Nom | Max | Unit |
|--|-----|-----|-----|------|
| Input voltage range | 6 | - | 32 | V |
| Over-voltage | - | - | 36 | V |
| Current draw in on state (excluding outputs) | - | - | 300 | mA |
| Current draw in on state (including outputs) | - | - | 13 | A |
| Current draw in sleep <i>mode</i> ¹³ | - | - | 1 | mA |
| Inline fuse required on power pins (ATO <i>style</i>) ¹⁴ | - | 25 | - | A |
| Number of power pins | - | 3 | - | - |

¹³ Assumes there is no current flow through input or output connections in harness. Either active high inputs are not connected to battery during sleep mode, or active-low inputs are not connected to ground during sleep mode.

¹⁴ This is required to ensure proper reverse battery protection on the VMM. Failure to include this fuse in the end application harness could result in damage to the VMM and/or the application harness.

| Item | Min | Nom | Max | Unit |
|-----------------------|-----|-----|-----|------|
| Number of ground pins | - | 4 | - | - |

9.1.2. Logic and Output Power Installation Connections

When connecting the VMM0604 logic and output power, you should be aware of the following:

- Logic and output power connections are made using the VBATT and GND pins.
- The number of wires needed to connect the VMM0604 power depends on the amount of current required by the application. It is recommended to use **one (1) 16 AWG wire** for every **8 A** of expected output current; however, this is not always true and ultimately depends on your application.
- The VMM0604 is protected against reverse battery connections by an internal high-current conduction path that goes from ground to power. To protect the VMM0604 from damage in a reverse battery condition, place a fuse of **25 A or less** in series with the power wires in the application harness.
- All power connections to the VMM0604 should be fused to protect the vehicle harness.



INFORMATION

The system designer is responsible for selecting the appropriate fuses. Select fuse sizes by multiplying the maximum continuous current during normal operation by 1.333 (75% de-rating factor). Do not use slow blow fuses for this application.

The following shows a typical logic and output power connection:

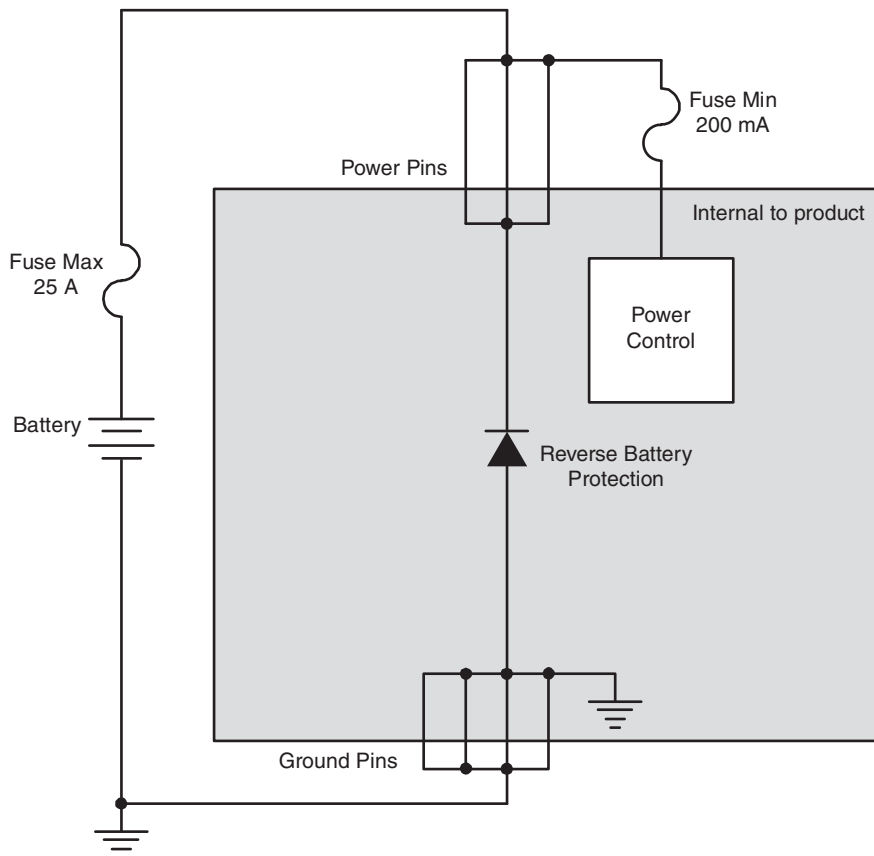

Figure 13: Logic and output power installation connections

9.2. Sensor Power

The VMM0604 has one pin dedicated to providing power to external sensors called `SENSOR_SUPPLY`.



WARNING

Do not drive more than **100 mA** of current through the `SENSOR_SUPPLY` pin. If you do, the pin will protect itself by dropping the voltage, which will result in a lack of power to your sensors, potentially causing unknown vehicle responses.

9.2.1. Sensor Power Capabilities

`SENSOR_SUPPLY` is a 5 V linear power supply that is capable of continuously providing 100 mA to external sensors.



INFORMATION

The voltage provided to the VMM0604 must be 6.5 V or greater to ensure the `sensor_supply` can provide 5 V.

Depending on system voltage, `SENSOR_SUPPLY` is capable of delivering different amounts of current to the sensors, as detailed in the following table:

Table 14: Maximum Sensor Current at Various Voltages

| Input Voltage | Maximum Sensor Current |
|---------------|------------------------|
| 6.5–14 VDC | 100 mA |
| 14–24 VDC | 50 mA |
| 24–32 VDC | 30 mA |

The following table provides specifications for the VMM0604 sensor power:

Table 15: Sensor Power Specifications

| Item | Min | Nom | Max | Unit |
|---|-----|-----|-----|------|
| Input voltage range | 6.5 | - | 32 | V |
| Over-voltage | - | - | 36 | V |
| Output voltage range | 4.8 | 5 | 5.2 | V |
| Output voltage accuracy | - | 4 | - | % |
| Output current (linear) @ 6.5 to 14 V battery | 0 | - | 100 | mA |
| Output current (linear) @ 14 to 24 V battery | 0 | - | 50 | mA |
| Output current (linear) @ 24 to 32 V battery | 0 | - | 30 | mA |
| Number of sensor power connector pins | - | 1 | - | - |

9.2.1.1. Sensor Power Fault Responses

`SENSOR_SUPPLY` is designed to survive short-to-battery, short-to-ground, and over-current events. If these events occur, the circuit will recover as described in the following table:

Table 19: Sensor Power Fault Recovery

| Event | Recovery |
|--|---|
| Short-to-battery (sensor voltage = battery voltage) | Sensor voltage recovers when the short is removed. |
| Short-to-ground (sensor voltage = ground) | Sensor voltage recovers when the short is removed. |
| Over-current (sensor voltage = ground) | Sensor voltage recovers when the over-current condition is removed. |

9.2.2. Sensor Power Installation Connections

For information on how to connect sensors, refer to Application Examples.

10. Communication

The only type of communication available to the VMM0604 is **Controller Area Network (CAN)** communication.

10.1. Controller Area Network (CAN)

The VMM0604 hardware provides CAN communication according to the **SAE J1939 specification**, making the VMM0604 compatible with any CAN-based protocol through software.

CAN communication is used to communicate the status of multiple modules that are connected together in the same network.

10.1.1. J1939 CAN Capabilities

The CAN communicates information at a rate of **250 kbps**. VMM0604 input and output information is transmitted through the CAN at a broadcast rate of **40 Hz**. Lack of regular CAN communication is an indication that there is either a problem with a module in the network, or a problem with the CAN bus.

The following table provides specifications for the CAN:

Table 17: CAN Specifications

| Item | Min | Nom | Max | Unit |
|---------------------------|-----|-----|------|------|
| Max voltage | - | - | 32 | V |
| Onboard terminator option | - | No | - | |
| Wake on CAN option | - | No | - | |
| Baud rate | - | 250 | 1000 | kbps |
| J1939 compliant | - | Yes | - | |

10.1.2. J1939 CAN Installation Connections

The CAN connection for the VMM0604 should conform to the J1939 standard.

For a list of J1939 connection considerations, refer to the SAE J1939 specifications available through the Society for Automotive Engineers. SAE J1939-11 covers the physical aspects of the CAN bus including cable type, connector type, and cable lengths.



INFORMATION

The VMM0604 does not have a CAN termination resistor, which is based on the assumption that the CAN bus is terminated in the harness.

The following lists the elements that are required for a J1939 CAN connection:
Vansco Multiplexing Module (VMM) 0604

- **CAN Cable:** A shielded twisted-pair cable should be used when connecting multiple modules to the CAN bus. The cable for the J1939 CAN bus has three wires: CAN High, CAN Low, and CAN Shield (which connect to the corresponding CAN_HIGH, CAN_LOW, and CAN_SHIELD pins on the connector). The CAN cable must have an impedance of 120 Ω .
 - o **The CAN cable is very susceptible to system noise;** therefore, CAN Shield must be connected according to the following:
 - a. Connect CAN Shield to the point of least electrical noise on the CAN bus.
 - b. Connect CAN Shield as close to the centre of the CAN bus as possible.
 - c. Use the lowest impedance connection possible.



NOTICE

Ground loops can damage electronic modules. The CAN Shield can only be grounded to one point on the network. If grounded to multiple points, a ground loop may occur.

- **CAN Connectors:** Industry-approved CAN connectors are manufactured by ITT Canon and Deutsch, and come in either “T” or “Y” configurations.
- **CAN Harness:** The CAN harness is the “main backbone” cable that is used to connect the CAN network. This cable cannot be longer than 40 metres, and must have a 120 Ω terminator resistor at each end. The 120 Ω terminator resistors eliminate bus reflections and ensure proper idle state voltage levels.
- **CAN Stubs:** The CAN stubs cannot be longer than 1 m, and each stub should vary in length to eliminate bus reflections and ensure proper idle state voltage levels.
- **Max Number of Modules in a System:** The CAN bus can handle a maximum of 30 modules in a system at one time.

The following shows a typical CAN connection using the SAE J1939 standard:

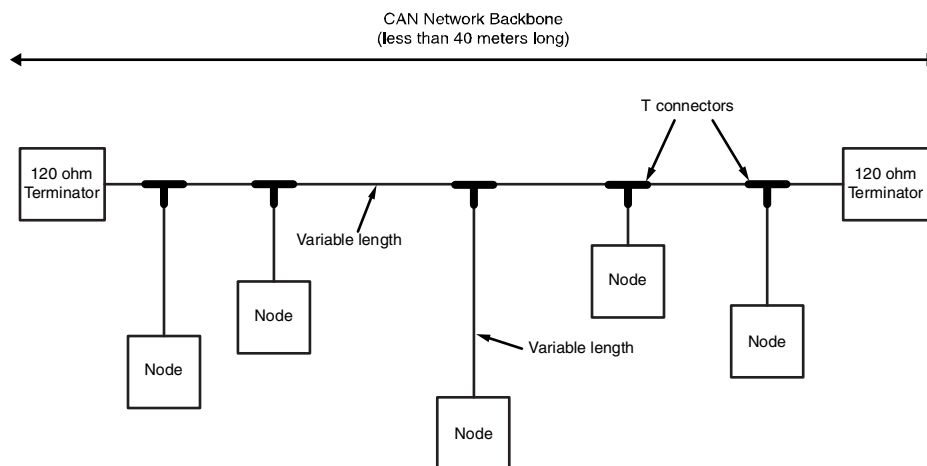

Figure 14: J1939 CAN connection

11. Connectors

The VMM0604 has one 35-pin Ampseal connector that connects to inputs, outputs, power, and the Controller Area Network (CAN). The connector has keying that prevents you from incorrectly mating it to the vehicle harness. The vehicle harness must be designed to interface with the connector.

The following is a picture of the required mating connector:

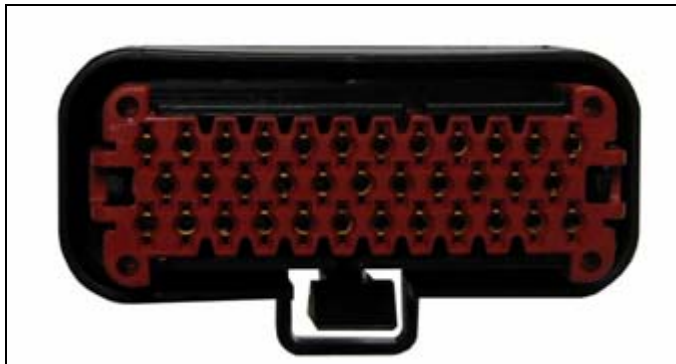

Figure 15: Black (J1) connector

11.1. Mating Connector Part Numbers

The following table shows the part numbers for the mating connectors and terminals that are used in the vehicle harness:

Table 18: Mating Connector Part Numbers

| Connector | Shell Part Number | Terminal Part Number |
|----------------------|-------------------|-------------------------------|
| Black (J1) Connector | AMP 776164-1 | 20-16AWG, Gold: AMP 770-854-3 |

11.2. Connector Pin-outs

Connector pins connect to inputs, outputs, power, and communication channels. They provide the interface between the vehicle harness and the internal circuitry of the VMM0604.

The following table shows the pin-out for the VMM0604 connector:

Table 19: Connector Pin-out

| Pin no. | Name | Function |
|---------|---------------|---------------------|
| 1 | OUTPUT3_3A_HS | 3A High-side output |
| 2 | OUTPUT7_3A_LS | 3A Low-side output |

| Pin no. | Name | Function |
|---------|---------------|--------------------------------------|
| 3 | SENSOR_SUPPLY | Power for external sensors |
| 4 | ADDR4 | Addressing digital input |
| 5 | ADDR3 | Addressing digital input |
| 6 | ADDR2 | Addressing digital input |
| 7 | ADDR1 | Addressing digital input |
| 8 | VBATT | Logic and output power |
| 9 | VBATT | Logic and output power |
| 10 | VBATT | Logic and output power |
| 11 | OUTPUT5_3A_LS | 3A Low-side output |
| 12 | OUTPUT1_3A_HS | 3A High-side output |
| 13 | N-C | Not connected |
| 14 | ADDR5 | Addressing digital input |
| 15 | CAN1_H | CAN 1 High |
| 16 | GND | Ground |
| 17 | INPUT6_ADF | Input: Analog, Digital, or Frequency |
| 18 | GND | Ground |
| 19 | N-C | Not connected |
| 20 | GND | Ground |
| 21 | N-C | Not connected |
| 22 | GND | Ground |
| 23 | N-C | Not connected |
| 24 | OUTPUT8_3A_LS | 3A Low-side output |
| 25 | OUTPUT4_3A_HS | 3A High-side output |
| 26 | CAN_SHLD | CAN Shield |
| 27 | CAN1_L | CAN 1 Low |
| 28 | POWER_CONTROL | Active high wake-up input |
| 29 | INPUT5_ADF | Input: Analog, Digital, or Frequency |
| 30 | INPUT4_ADF | Input: Analog, Digital, or Frequency |
| 31 | INPUT3_ADF | Input: Analog, Digital, or Frequency |
| 32 | INPUT2_ADF | Input: Analog, Digital, or Frequency |
| 33 | INPUT1_ADF | Input: Analog, Digital, or Frequency |
| 34 | OUTPUT2_3A_HS | 3A High-side output |
| 35 | OUTPUT6_3A_LS | 3A Low-side output |

12. Installing a VMM0604 into a Vehicle

Because every system is different, it is difficult for us to provide specific instructions on how to install a VMM0604 into a vehicle. Instead, we have provided **mechanical, environmental, and electrical guidelines and requirements** that you should be aware of before installing the product.



INFORMATION

The vehicle manufacturer is responsible for creating procedures for mounting the VMM0604 in a vehicle during production assembly.

12.1. Mechanical Guidelines

Ensure you review the following mechanical guideline sections before installing the VMM0604 into a vehicle.

12.1.1. VMM0604 Dimensions

The following shows the dimensions of the VMM0604 in millimeters [inches]:

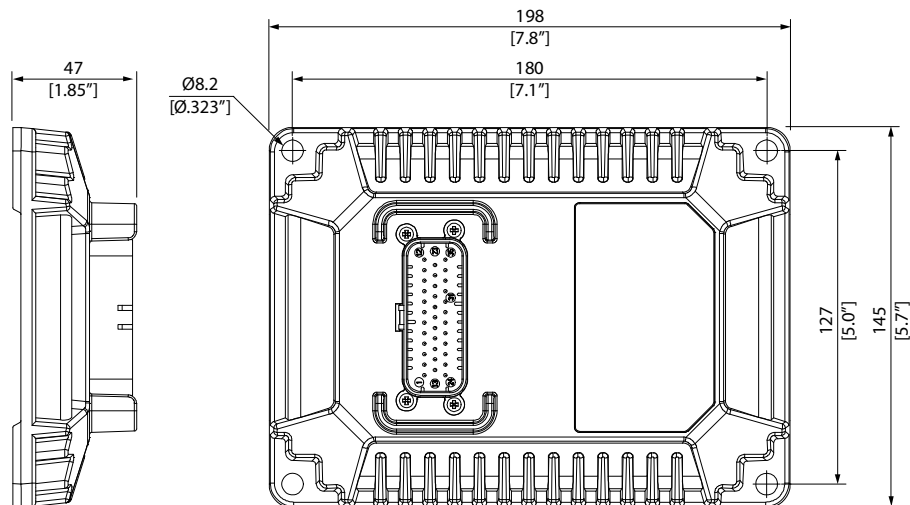

Figure 16: Dimensions of the VMM0604

12.1.2. Selecting a Mounting Location

The VMM0604 can be installed in the vehicle's cab, or on the chassis. If used for a marine application, ensure it is protected from excessive salt spray.

Before mounting the VMM0604, ensure you review the following environmental and mechanical requirements.

**NOTICE**

Do not install the VMM0604 close to any significant heat sources, such as a turbo, exhaust manifold, etc. Also avoid installing the VMM0604 near any drive-train component, such as a transmission or engine block.

12.1.2.1. Environmental Requirements**NOTICE**

The VMM0604 warranty does not cover damage to the product when exposed to environmental conditions that exceed the design limitations of the product.

Review the following environmental specifications before selecting a mounting location for the VMM0604:

- The VMM0604 must be in an environment that is within its ambient temperature range.
 - Safe operating temperature range for a VMM is **-40°C to +85°C**.
- The VMM0604 must be in an environment that does not exceed its particle ingress rating.
 - The sealing standard for the VMM0604 is **EP455 level 1 (IPX6)**.

**NOTICE**

The VMM0604 has not been tested for water ingress according to the EP455 level 1 standard.

- The VMM is protected from **aggressive pressure wash up to 1000 psi @ 1 m (3.28 ft.)**

**NOTICE**

Exercise caution when pressure washing the VMM0604. The severity of a pressure wash can exceed the VMM0604 pressure wash specifications related to water pressure, water flow, nozzle characteristics, and distance. Under certain conditions a pressure wash jet can cut wires.

12.1.2.2. Mechanical Requirements

Review the following mechanical requirements before selecting a mounting location for the VMM0604:

- The VMM0604 should be mounted vertically so **moisture will drain away from it**.
- The wire harness should have drip loops incorporated into the design to divert water away from the VMM0604.
- The harness should be **shielded from harsh impact**.

- The harness should **connect easily** to the connector and have **adequate bend radius**.
- The **labels and LEDs** should be easy to read.
- The VMM0604 should be in a location that is **easily accessible for service**.

12.1.3. Mounting the VMM0604 to a Vehicle

It is up to the original equipment manufacturer (OEM) to ensure the product is securely mounted to the vehicle.

The following guidelines are related to physically attaching the VMM0604 to a vehicle:

- The VMM0604 should be secured with **bolts in all four bolt holes** using 1/4"-20 **Hex Head** or equivalent metric size (6 mm) bolts.
- The bolts should be tightened according to the fastener manufacturer's tightening torque specifications..

12.2. Electrical Guidelines

The following sections provide electrical guidelines to install the VMM0604 in a vehicle.

12.2.1. Designing the Vehicle Harness

The vehicle manufacturer is responsible for designing a vehicle harness that mates with the VMM0604 connector(s).

The vehicle harness design depends on the following:

- How the VMM0604's inputs, outputs, communication, and power pins are configured.
- Other components on the vehicle and their physical locations.
- The routing of the harness.

For guidelines and recommendations on how to connect the different elements of the VMM0604, refer to the *Installation Connections* sections found within each input, output, communication, and power section in this manual.

12.2.2. Connecting the Vehicle Harness to the VMM0604

Once the vehicle harness is designed, it can be connected to the VMM0604 simply by clicking the mating connector into the connector port on the VMM0604.

13. Application Examples

The purpose of this section is to provide examples of how the VMM0604 can be used for different purposes.

The following examples are covered in this section:

- Implementing safety interlocks
- Controlling indicator lights
- Controlling a proportional valve
- Controlling motor speed
- Using one analog input as two digital inputs
- Connecting sensors



INFORMATION

These examples are for illustrative purposes only.

13.1. Implementing Safety Interlocks

Safety is paramount when creating controls for a vehicle.

One safety feature that can be implemented with the VMM0604 is to ensure the vehicle doesn't move when it is not being used, and no one is sitting in the operator's seat.

To prevent the vehicle from moving when no one is sitting in the operator seat:

1. Place a **seat switch interlock** on the operator seat and connect the switch to a digital input.
2. Write ladder logic application code for the digital input so that it shuts down critical vehicle functions when the switch is open (when no one is sitting in the seat).



INFORMATION

The example above may cause unwanted shutdowns if the operator moves around while controlling the vehicle. To prevent this, use software filtering that will prevent the vehicle from shutting down unless the switch is open for more than a defined period of time.

The following diagram shows a typical seat switch interlock connection:

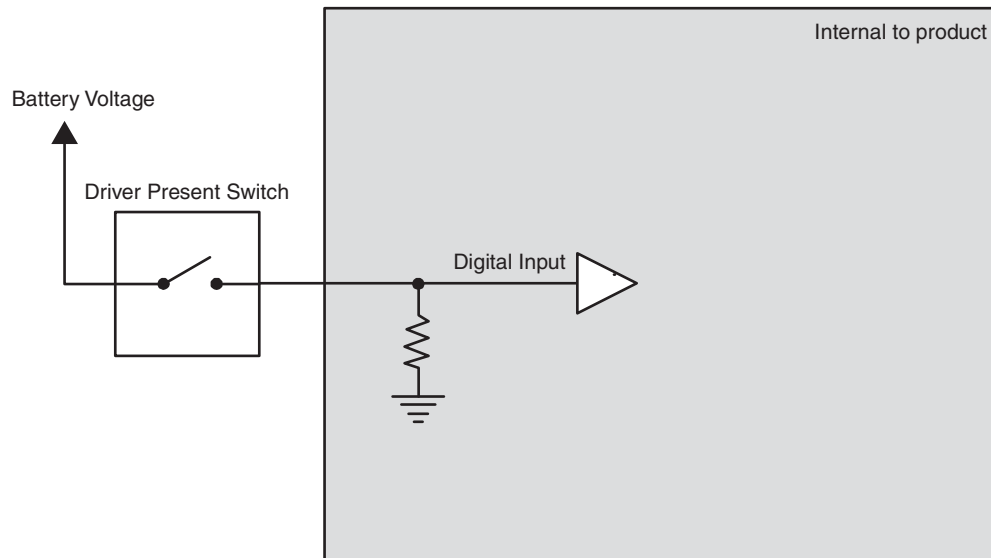

Figure 17: Seat switch interlock connection

13.2. Controlling Indicator Lights

Multiple VMM0604 can be used together in a system to control a vehicle's indicator lights.

The VMM0604s would communicate over CAN, and be connected according to the following:

- One VMM0604 could be wired to the rear indicator lights
- One VMM0604 could be wired to the front indicator lights
- One VMM0604 could be wired to the turn signal and hazard switches

The following shows how to connect three VMM0604s together in a system to control indicator lights:

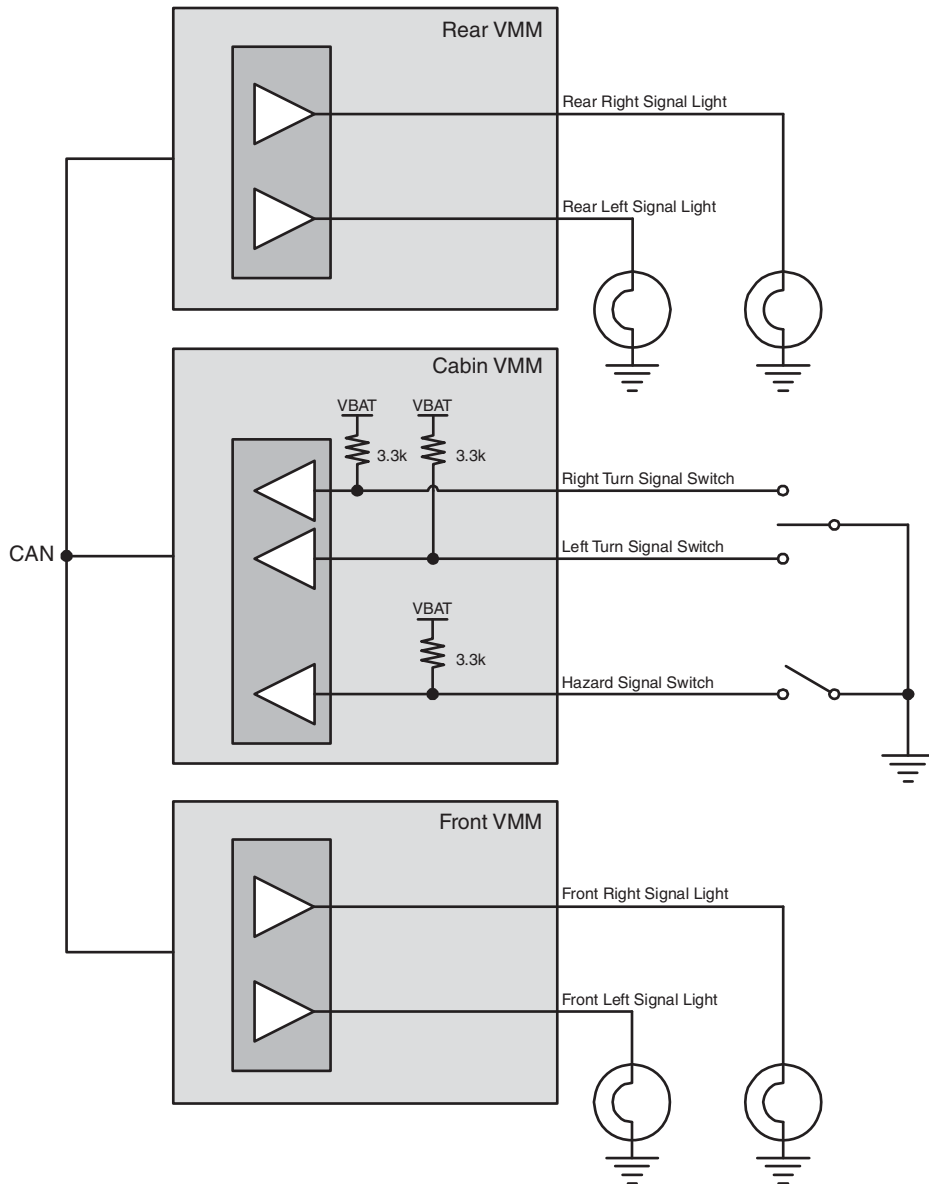

Figure 18: Indicator light connections

13.3. Controlling a Proportional Valve



INFORMATION

The VMM0604 has Proportional Integral Differential (PID) capabilities that make it possible to control devices like proportional valves through software. Refer to the appropriate software manual, or contact your Parker Vansco Account Representative for more details about software. This section only provides hardware connection information.

The VMM0604 can be used to control a proportional hydraulic valve through a **high-side output with PWM capability**, and a **low-side output with current sense**.

When making the connection, it is highly recommended to use the high-side and low-side outputs in pairs to avoid potential problems.

- The high-side output would drive power to the valve coil and adjust the duty cycle of a PWM signal.
- The low-side output would be used as a return path to ground for the valve coil, and provides feedback on the amount of current flowing through the valve coil.

The application code should be written so that the PWM duty cycle for the output is adjusted to achieve a target current through the valve coil.

- If current feedback is lower than target, the PWM duty cycle should increase to boost average current through the valve coil.
- If the current feedback is higher than target, the PWM duty cycle should decrease to reduce average current through the valve coil.

The following shows how to connect a high-side and low-side output to control a proportional hydraulic valve:

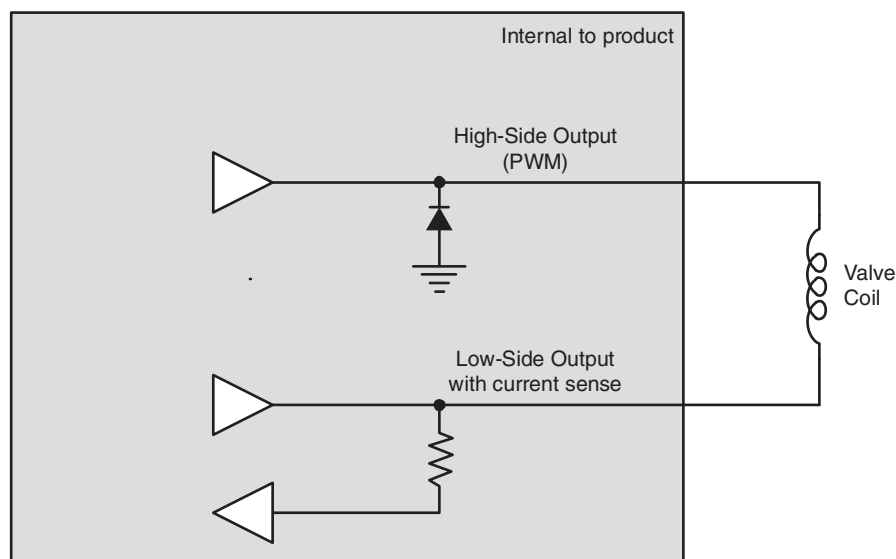

Figure 19: Connection for controlling a proportional valve

13.4. Controlling Motor Speed



INFORMATION

The VMM0604 has Proportional Integral Differential (PID) capabilities that make it possible to control devices like proportional valves through software. Refer to the appropriate software manual, or contact your Parker Vansco Account Representative for more details about software. This section only provides hardware connection information.

The VMM0604 can be used to control the DC motor speed of motors that provide a tachometer output.

To do this, you would use a **high-side output with PWM capabilities** to control the speed of the motor, and a **DC-coupled frequency input** to monitor the output from the motor.

The application code should be written so that the PWM duty cycle for the high-side output is adjusted to achieve a target speed (frequency) for the motor.

- If the frequency feedback is lower than target, the PWM duty cycle should increase to boost the average current through the motor to speed it up.
- If the frequency feedback is higher than target, the PWM duty cycle should decrease to reduce average current through the motor to slow it down.

The following shows how to connect the VMM0604 to control the speed of a motor:

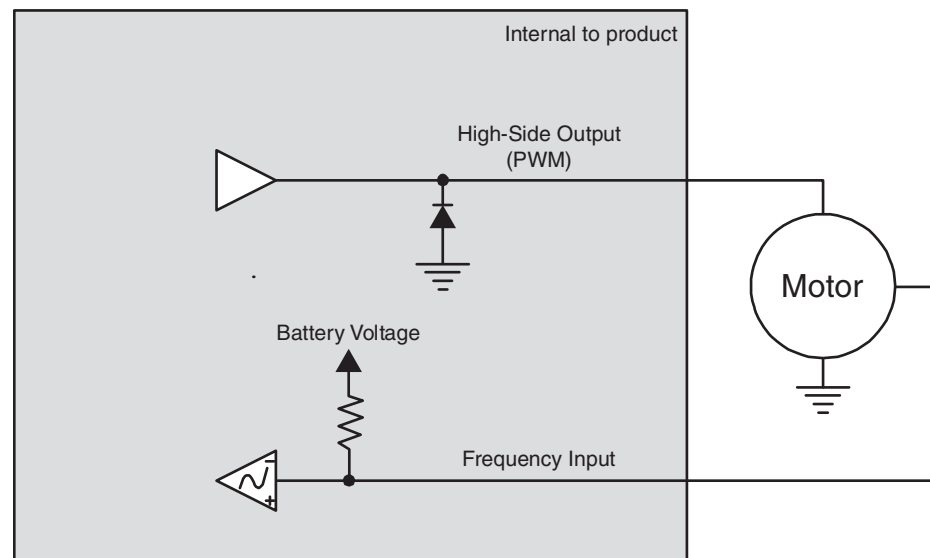

Figure 20: Connection for controlling motor speed

13.5. Using one Analog Input as Two Digital Inputs

The VMM0604 allows you to use one analog input as two digital inputs, which is useful in reducing harness lead or if you are running out of digital inputs in your system.

Vansco Multiplexing Module (VMM) 0604

55

To do this, you would connect the analog input to a single pole, double throw (SPDT) switch.



INFORMATION

You will need to write ladder logic that controls the switch according to the voltage value readings provided by the analog input. Refer to the appropriate ladder logic help file, or contact your Parker Vansco Account Representative for more information on writing ladder logic.

When making the connection, ensure there is a voltage difference between the two pins on the SPDT switch. This can be done by

- enabling the internal pull-up resistor on the analog input (done through software);
- adding a resistor to one of the pins on the SPDT switch.

The following shows how to connect an analog input to a SPDT switch:

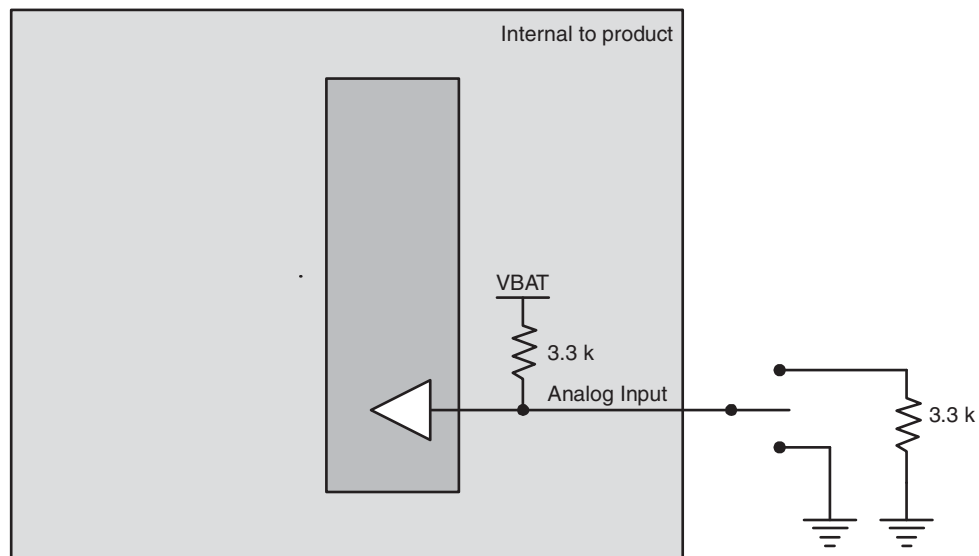

Figure 21: Connecting an analog input to an SPDT switch

13.6. Controlling a Linear Actuator



INFORMATION

The VMM0604 has Proportional Integral Differential (PID) capabilities that make it possible to control devices like an electric or hydraulic linear actuator through ladder logic. Refer to the appropriate ladder logic help file, or contact your Parker Vansco Account Representative for more details about ladder logic. This section only provides hardware connection information.

The VMM0604 can control the position of a linear actuator by using **two h-bridges of high-side and low-side outputs**, and monitor the position of the actuator using an

Vansco Multiplexing Module (VMM) 0604

56

analog input. When making the connections, it is highly recommended to use the high-side and low-side outputs in pairs to avoid potential problems (use high-side output 1 with low-side output 1, etc.).

The ladder logic should be written to adjust the PWM duty cycle and direction of the current to achieve a target position for the linear actuator.

The following shows how to connect high-side and low-side outputs for controlling a linear actuator:

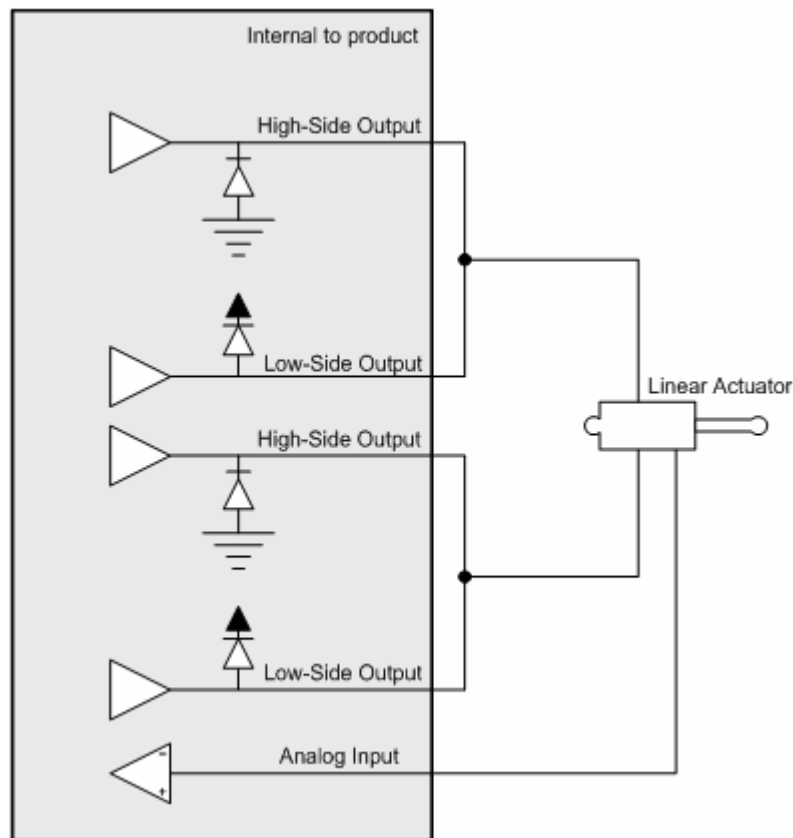

Figure 22: Connection for controlling a proportional valve

13.7. Connecting Various Sensors

There are many types of sensors that can be connected to the VMM0604, as follows:

- Open collector sensors
- Variable resistance sensors
- Variable reluctance sensors
- Switch sensors
- Voltage sensors
- CMOS sensors
- Potentiometer (ratiometric) sensors

**INFORMATION**

To optimize the reading accuracy for sensors, dedicate one of the main ground pins (called GND) as a low-current ground return for all sensors on the vehicle.

**INFORMATION**

When connecting sensors to the VMM0604 be sure to use the sensor's specification to ensure the VMM0604 is configured correctly for the sensor.

13.7.1. Open Collector

Open collector sensors are compatible with each type of input on the VMM0604.

Open collector sensors are typically used in applications that require digital or frequency measurements. They work by pulling voltage down to ground or up to power when activated, and are basically a switch that turns "on" and "off".

**INFORMATION**

Open collector sensors need a pull-up or pull-down resistor to bias the state of the sensor when the sensor is not activated. Pull-up and pull-down resistors are internal to the VMM0604.

The following shows a typical open collector sensor connection:

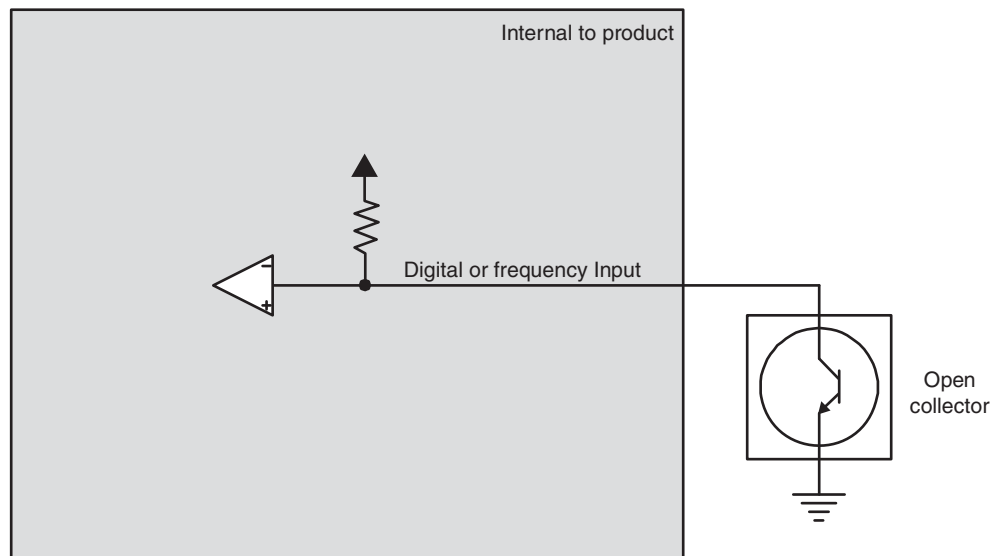

Figure 23: Open collector sensor connection

13.7.2. Variable Resistance

Variable resistance sensors change impedance to represent its measured value, and are compatible with analog inputs.

Variable resistance sensors are typically used in thermal and pressure applications. They work by changing the voltage reading on the sensor according to changes in pressure or temperature in the application.

The VMM0604 cannot measure resistance directly.

To make the VMM0604 measure resistance accurately, do the following:

- Include a precision pull-up resistor between the sensor and the sensor power output (called `SENSOR_SUPPLY`).
- Ensure the value of the precision resistor allows the maximum possible resolution for the sensor's input.
- Dimension the precision resistor to get the maximum voltage range from the sensor.



INFORMATION

Variable resistance sensor accuracy may suffer at the extremes of the sensor's range. A tolerance analysis should be performed to ensure measurement accuracy is acceptable for your application.

The following shows a typical variable resistance sensor connection:

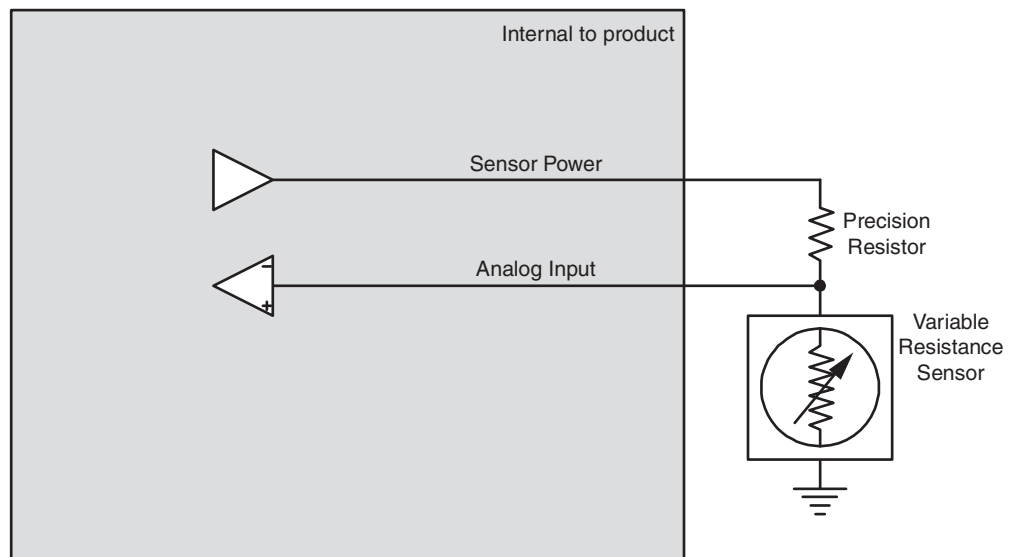

Figure 24: Variable resistance sensor connection

13.7.3. Variable Reluctance

Variable reluctance sensors are typically used in frequency measurement applications, and are compatible with AC-coupled frequency inputs.

Variable reluctance sensors do not require power (the power is induced), and they create frequency by out-putting a sine wave type signal. They work by using an increase or decrease in a magnetic field to detect the proximity of a part or device.

The following shows a typical variable reluctance connection:

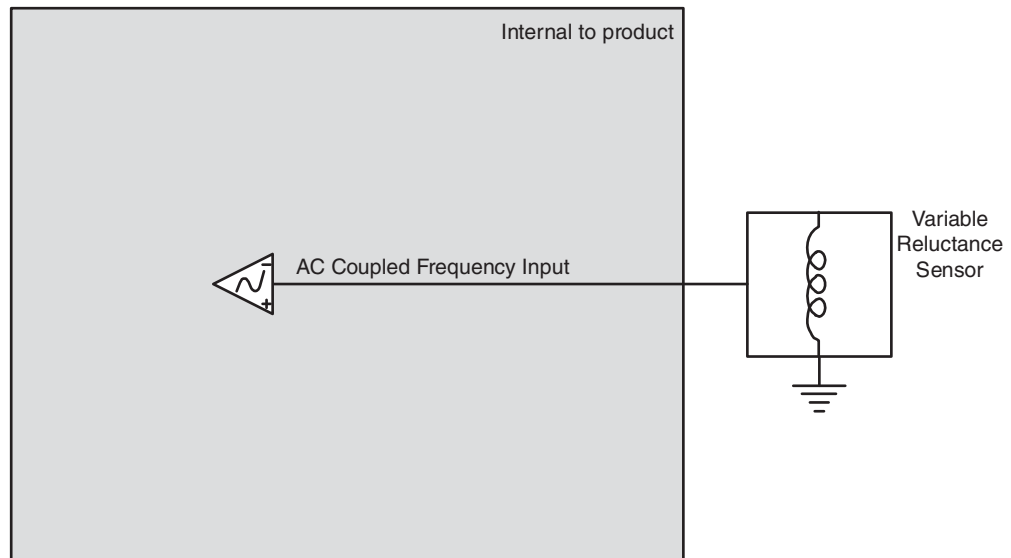

Figure 25: Variable reluctance sensor connection

13.7.4. Switch

A switch is a type of sensor that uses mechanical contacts in one of two states: open or closed. Sensor switches are used to turn sensors on and off, and can be wired directly to digital inputs.

Active-low sensor switches are common. To use active-low switches, the internal pull-up resistor on the input that the sensor is wired to must be enabled.



WARNING

Use of Active low switches is not recommended. A broken wire on this type of switch, if it makes contact with the chassis, will activate the function.

Active-high sensor switches are another common type which are generally safer. To use active-high switches, the internal pull-down resistor for the input that the sensor is wired to must be enabled.

The following shows a typical sensor switch connection:

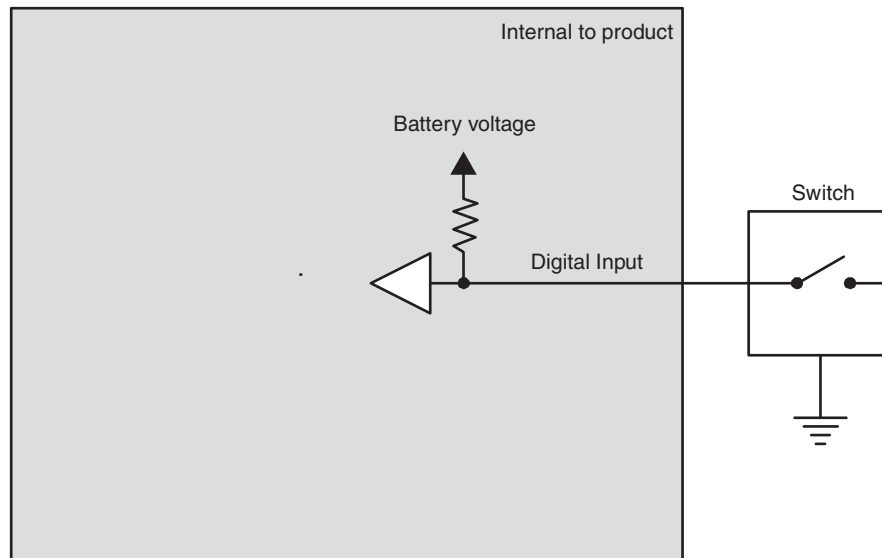

Figure 26: Switch sensor connection

13.7.5. Voltage

Voltage type sensors work by driving an analog voltage signal to report the sensor's measured value.

Voltage sensors are compatible with analog inputs, and are typically used in applications that require variable voltage measurements.



INFORMATION

Ensure you configure the analog input voltage (gain and attenuation factors) so the input's voltage is close to, but higher than, the maximum output voltage of the sensor.

The following shows a typical voltage sensor connection:

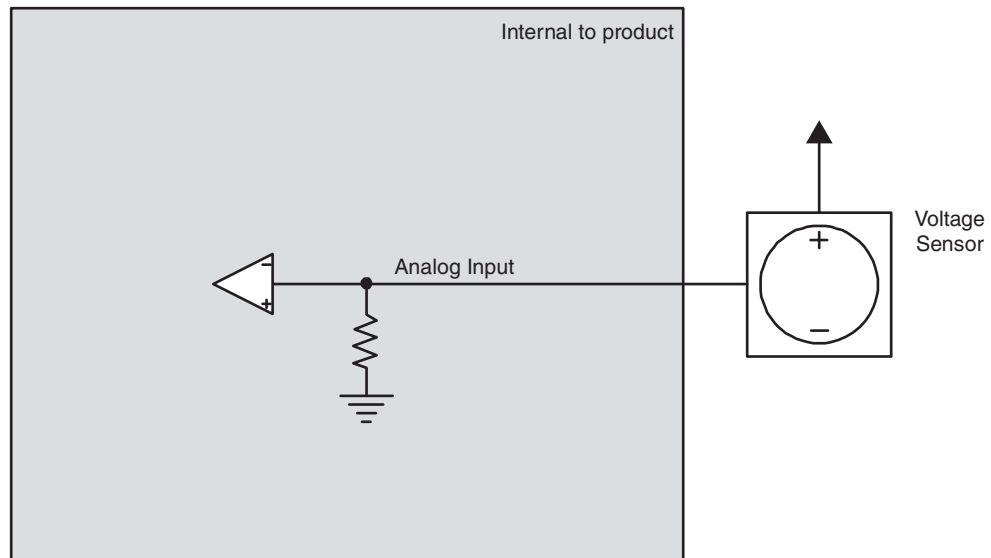

Figure 27: Voltage sensor connection

13.7.6. CMOS

A sensor with a CMOS-type output drives a high and low signal, and is typically used in digital and frequency applications, and therefore, CMOS sensors can be wired directly to digital and frequency inputs.

The following shows a typical CMOS sensor connection:

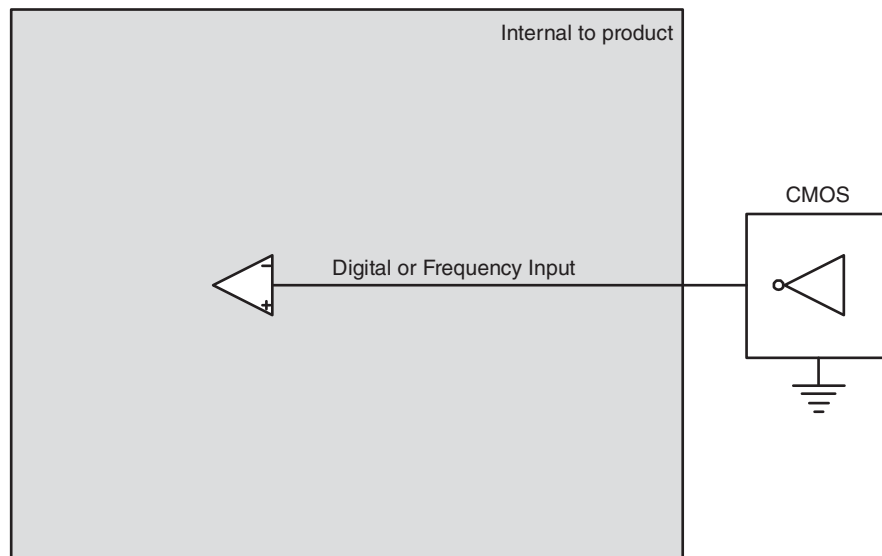

Figure 28: CMOS sensor connection

13.7.7. Potentiometer (Ratiometric)

Potentiometers and other ratiometric type sensors can be wired directly to analog inputs.

Vansco Multiplexing Module (VMM) 0604

62

Potentiometers are resistive devices that use a wiper arm to create a voltage divider. Changes to resistive measurements happen as the wiper arm moves along a resistive element.

When connecting potentiometer sensors, it is important to do the following:

- Connect one end of the sensor to the `SENSOR_SUPPLY` pin, and the other end to a `GND` pin on the VMM0604.
- Connect the sensor signal to an analog input.

The following shows a typical potentiometer sensor connection:

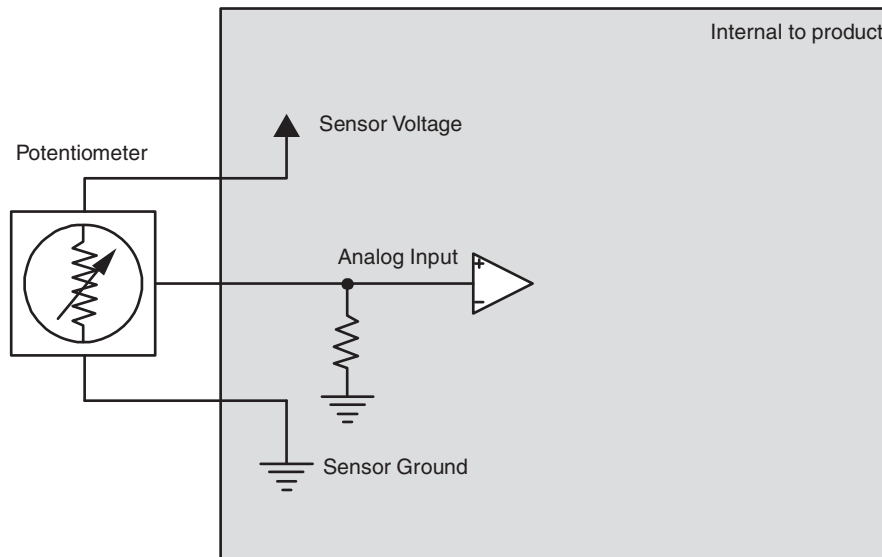

Figure 29: Potentiometer (ratiometric) sensor connection

14. Startup

14.1. Start-up procedures

This chapter contains instructions for action to be taken in connection with the initial start.



WARNING

Risk of injury!

If the control system is not fitted properly, the machine could move uncontrollably. The machine's engine shall not be started before the control system is completely fitted and its signals are verified.

14.1.1. Starting the control system

Start the control system as follows:

- Prior to start, all modules and cables are to be fitted correctly.
- Check fuses, i.e. make sure that the supply voltage to the modules is equipped with the correct fuse.
- Make sure that connections for supply voltage and return lines are correct in the cable's conductor joint.
- Make sure the emergency stop works.
 - o The emergency stop should disconnect the supply voltage to all modules.

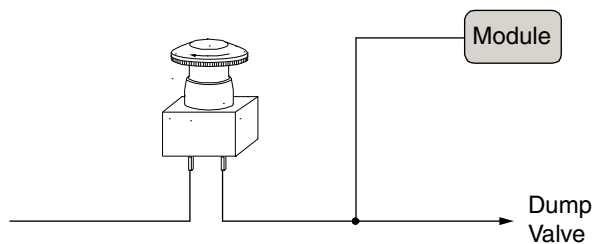

Figure 30: Emergency stop

Alternatively, the emergency stop may also shut off the diesel engine or a dump valve, and with that depressurize the hydraulic system.

14.1.2. Prepare for system start



WARNING

Make sure no one is in dangerous proximity to the vehicle to avoid injuries when it starts.

Prepare for the initial system start as follows:

- The engine for the hydraulic system's pump shall be in off position.
- Make sure that all connectors are properly connected.
- Turn on the control system.
- Make sure that voltage is being supplied to all modules.
- Make sure the emergency stop is functioning properly.

14.1.3. Start the system

Start the system as follows:

- Start the engine for the hydraulic system's pump, assuming that the above mentioned inspections have been carried out and shown correct values.
- Calibrate and adjust input and output signals, and check every output function carefully.
- In addition to these measures, the machine shall also meet the machine directives for the country in question.

15. Appendix A

15.1. VMM0604 Technical Overview

The following table lists the verification tests that were performed for the VMM0604:

Table 20: Test Specifications

| Ref # | Test Specification | Test Description | Deviated from Plan? |
|-------|--------------------------------------|------------------------------|-------------------------|
| 1. | J1455 (Jun 2006) Section 4.1.3.1 | 24 Hour Thermal Cycle | No |
| 2. | J1455 (Jun 2006) Section 4.1.3.2 | Thermal Shock | No |
| 3. | EP455 (Feb 03) Section 5.1.2 | Storage Temperature | No |
| 4. | J1455 (Jun 2006) Section 4.2.3 | 24 Hour Humidity Cycle | No |
| 5. | EP455 (Feb 03) Section 5.13.2 | Humidity Soak | No |
| 6. | J1455 (Jun 2006) Section 4.3.3 | Salt Spray Atmosphere | No |
| 7. | EP455 (Feb 03) Section 5.8.2 | Chemical Exposure | No |
| 8. | EP455 (Feb 03) Section 5.4.1 | Solar Radiation - UV Effects | <u>Yes¹⁵</u> |
| 9. | EP455 (Feb 03) Section 5.4.1 | Pressure Wash | No |
| 10. | J1455 (Jun 2006) Section 4.9.4.2 | Random Vibration | No |
| 11. | J1455 (Jun 2006) Section 4.10.3.1 | Handling Drop | No |
| 12. | J1455 (Jun 2006) Section 4.11.3.3 | Harness Shock | No |
| 13. | J1455 (Jun 2006) Section 4.11.3.4 | Operational Shock | No |
| 14. | J1455 (Jun 2006) Section 4.13.1 | Operating Voltage | No |
| 15. | EP455 (Feb 03) Section 5.10.7 | Operational Power Up | <u>Yes¹⁶</u> |

¹⁵ UUT distance changed to 0.5 m instead of 0.75 m.

¹⁶ Rate changed to 1 V/s instead of 1 V/ms.

| Ref # | Test Specification | Test Description | Deviated from Plan? |
|-------|--|--|--------------------------|
| 16. | J1455 (Jun 2006) Section 4.13.1 | Cold Cranking Voltage | No |
| 17. | J1455 (Jun 2006) Section 4.13.1 | Jumper Starts Voltage | <u>Yes</u> ¹⁷ |
| 18. | J1455 (Jun 2006) Section 4.13.1 | Steady State Reverse Polarity | No |
| 19. | EP455 (Feb 03) Section 5.10.4 | Short Circuit Protection | <u>Yes</u> ¹⁸ |
| 20. | EP455 (Feb 03) Section 5.11.1 | Transient Accessory Noise | No |
| 21. | EP455 (Feb 03) Section 5.11.2 | Transient Alternator Field Decay | <u>Yes</u> ¹⁹ |
| 22. | EP455 (Feb 03) Section 5.11.3 | Transient Batteryless Operation Level | <u>Yes</u> ²⁰ |
| 23. | J1455 (Jun 2006) Section 4.13.2 | Transient Inductive Load Switching Pulse 1 | <u>Yes</u> ²¹ |
| 24. | J1455 (Jun 2006) Section 4.13.2 | Transient Load Dump | <u>Yes</u> ²² |
| 25. | J1455 (Jun 2006) Section 4.13.2 | Transient Mutual Coupling Power Lines | No |
| 26. | J1455 (Jun 2006) Section 4.13.2 | Transient Mutual Coupling Signal Lines | No |
| 27. | J1455 (Jun 2006) Section 4.13.2.2.3 | Electrostatic Discharge Operating | <u>Yes</u> ²³ |
| 28. | J1455 (Jun 2006) Section 4.13.2.2.3 | Electrostatic Discharge Handling | <u>Yes</u> ²⁴ |
| 29. | J1455 (Jun 2006) Section 4.13.3 | EMC - Susceptibility | <u>Yes</u> ²⁵ |
| 30. | J1455 (Jun 2006) Section 4.13.3 | EMC - Emissions | <u>Yes</u> ²⁶ |

¹⁷ Maximum voltage changed to 36 V instead of 48 V.

¹⁸ Each UUT pin was exposed to +32 V and system ground.

¹⁹ Source impedance of 1 ohm. Repetition rate of 0.02 Hz for 60 test cycles.

²⁰ Frequency swept from 800 Hz - 1500 Hz over 5 minute period. Applied voltage tested to $12+25.2\sin(2\text{Pift})$ for 24 V systems.

²¹ Source impedance is 10 ohm (equipment limitation).

²² Source impedance of 2 ohm, and signal of $28 +122e^{-t/0.1}$ as per J1455 draft issued April 8 (Rev 01).

²³ Approach rate of the test probe uncontrolled until discharge occurs. Test probe dimensions differ from J1455 requirements.

²⁴ Approach rate of the test probe uncontrolled until discharge occurs. Test probe dimensions differ from J1455 requirements.

²⁵ EMC geometry smaller than referenced specification recommends. Field strength is not 100 V/m over the whole frequency range.

²⁶ EMC geometry smaller than referenced specification recommends.

Vansco Multiplexing Module (VMM) 0604

15.2. Frequently Asked Questions (FAQ)

What are the recommended mounting practices for the VMM?

Refer to *Selecting a Mounting Location* for details.

Can the VMM be pressure washed or immersed in water?

Refer to *Environmental Requirements* on page 49 for details.

Can the VMM be used as an H-bridge?

Yes. The VMM has separate high-side and low-side outputs that can be combined in the harness to create an H-bridge. Refer to *Application Examples* on page 51 for more details on how to create an H-bridge.

Will the VMM work on a 42 V electrical system?

No. The VMM is designed for 12 V and 24 V systems.

Should the VMM be disconnected when the welding on a vehicle where it is installed?

All electrical devices should be disconnected during welding to avoid damaging them. The VMM warranty does not cover damage to the product when exposed to conditions that exceed the design limitations of the product.

How does the power control feature work?

Refer to *Power* on page 40 for details.

How should I wire my CAN network?

Refer to *Communication* on page 44 for details.

Where can I get J1939 cables and connectors?

Two manufacturers of J1939-rated connectors are ITT Canon and Deutsch. Raychem, a subdivision of Tyco, manufactures a shielded cable compliant with J1939-11. These are manufacturers that Parker Vansco has experience with, but this should not be considered an exhaustive list of J1939 cable and connector suppliers. Consult your local wire and connector distributors for details.

What kind of circuits can be created with the outputs?

Outputs can be used to create high-side, low-side, and H-bridge circuits, as shown in the following:

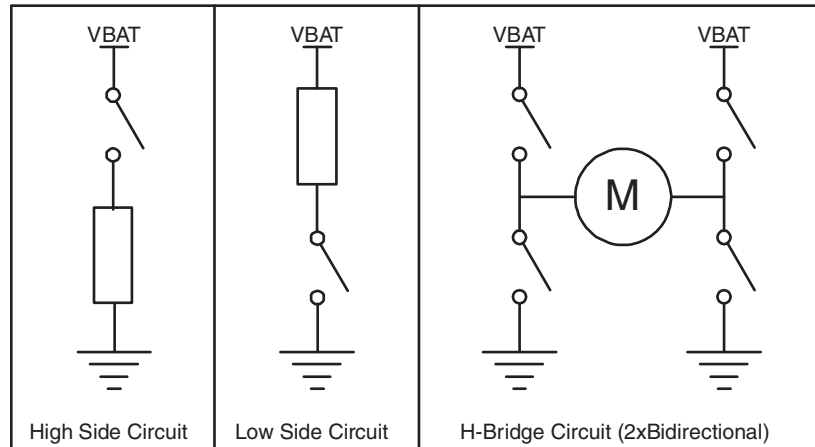

How do I program the VMM?

The VMM can be programmed using ladder logic. Consult your Parker Vansco Account Representative for more details.

Do the output currents require de-rating in certain conditions?

VMM outputs do not require de-rating. They are specified to operate continuously at the maximum temperature and the maximum rated current.

Can I plug my existing sensor into a VMM, and if so, how do I configure the input?

Refer to *Sensor Power* on page 42, or *Connecting Various Sensors* on page 57 for details on connecting sensors. Contact your Parker Vansco Account Representative for more information if needed.

Is it possible to purchase the VMM with a company logo printed on it?

Parker Vansco may consider customizing the overlay on a case-by case-basis. Consult your Parker Vansco Account Representative for details.

Is it possible to purchase a pre-programmed VMM?

Yes. Contact your Parker Vansco Account Representative for details on getting your VMM pre-programmed.

What torque should I apply to the mounting bolts?

Refer to the fastener manufacturer's recommendations for mounting bolt tightening torque.

Is it possible to get the VMMs with different connector options?

No. VMM connector options are not offered because the connectors are integral to the circuit board and mechanical enclosure design.

What is the maximum bus loading on the CAN network?

Requirements can vary by system; however, the industry standard is no more than 50% average bus loading.

Do I need to fuse VMM power?

Yes. Power connections to the VMM should be fused. Refer to *Power* on page 40 for more details.

Do I need to fuse VMM outputs?

VMM outputs are internally protected and no external fusing is required.

How much wetting current is provided by the VMM inputs?

Wetting currents can vary by module and by input type. Wetting current specifications are found in the specifications tables for each input.

Do I need an external flyback diode on my inductive load?

No. The VMM has internal flyback diodes as part of its high-side driver circuitry, and therefore an external flyback diode is not needed.

Is it a problem to have an external flyback diode on my inductive load? Will it affect my current sense measurement?

No. Having an external flyback diode present on circuits with internal flyback diodes will not cause problems and will not affect the current sense measurement.

Does the VMM offer analog outputs?

No; however, with the addition of external circuitry, an output can be PWM'd to generate an analog voltage.

Can I vary the frequency of my PWM output?

The frequency of each output is determined through software. Consult the appropriate software manual for details.

Can I connect VMM outputs in parallel?

You can connect on/off controlled outputs in parallel, but PWM'd outputs cannot as they are not guaranteed to be synchronized.

My VMM is broken. Who do I call regarding warranty?

Broken VMMs should be returned to the service department of the OEM, and the OEM will co-ordinate returns to the appropriate Parker Vansco service center.

Does the VMM support wireless connections?

The VMM does not support wireless connections; however, Parker Vansco offers a CAN to WiFi module. Contact your Parker Vansco Account Representative for details.

Can I connect the VMM to my existing J1939 devices?

Yes. The VMM is fully J1939 compatible and has generic J1939 messaging capability to support any custom communication scheme.

Can I use the VMM to power another VMM?

Yes, an output on your VMM can be used to power other VMMs, or to excite other VMMs' power control inputs.

Does the VMM support "Wake on CAN"?

No.

Can I run my VMM CAN bus faster than 250 kbps?

No. When the VMM is used in a VMM system, it can only communicate at 250kbps.

Can I use other Parker Vansco products such as the mVEC or CM3620 with my VMMs?

Yes, however, the software required for each is different. Interfacing to these modules must be done through the generic CAN and J1939 messaging included in the VMMS software tool.

15.3. Troubleshooting

This section assumes that the product is connected in a Development System.

The following table provides possible solutions for potential problems:

| Problem | Possible Causes | Possible Solutions |
|---|-------------------------------------|--|
| Everything is connected, but there is no CAN communication. | The VMM is not powered. | <ul style="list-style-type: none"> • Ensure all of your connecting points in the desktop setup are properly seated. • Ensure the power supply is on and connected to a VMM0604 within your desktop setup. • Ensure the power control input is active (refer to the power control input section for details). <p>The power LED will flash once every second when the VMM0604 is powered.</p> |
| | The CAN bus isn't set up correctly. | <ul style="list-style-type: none"> • Ensure there is a 120 Ω terminating resistor at each end of the CAN bus. |

16. Glossary of Terms

A

AC-coupled

A circuit that eliminates the DC offset voltage of the signal. This circuit is typically used with frequency inputs that have a DC offset. Note that the DC offset value varies by product.

active-high

Input type that is considered "on" when it reads a battery voltage level and "off" when it is floating or grounded.

active-low

Input type that is considered "on" when it reads a ground voltage level and "off" when it is floating or connected to battery voltage.

aliasing

A situation can arise in digital systems where a sampled analog value produces a measured signal with a frequency that is less than the actual analog signal. Aliasing occurs when the analog signal being sampled has a frequency greater than half the sample rate.

amplified

A circuit that applies a gain with a value greater than one (1) to a measured signal, which is typically used with analog inputs.

analog input

An input that allows a voltage level to be read and converted to discrete digital values within a microprocessor.

anti-alias filtering

Filters incorporated in hardware that ensure the analog value being read by the module does not have a frequency component greater than half the sample rate.

application software

A level of software that makes a product (hardware) perform desired functions for the end user.

attenuation

Decreasing the voltage level of an input signal to maximize the resolution of an input.

B**black box**

A custom compiled algorithm written in C programming language that allows a system designer to implement algorithms that are not possible in ladder logic.

C**CAN**

Controller Area Network

CAN High

One of the wires used in the shielded twisted-pair cable, which provides the positive signal that, when connected with CAN Low, provides a complete CAN differential signal.

CAN Low

One of the wires used in the shielded twisted-pair cable, which provides the negative signal that, when connected with CAN High, provides a complete CAN differential signal.

CAN Shield

A shielding that wraps around the CAN High and CAN Low wires (twisted-pair), completing the shielded twisted-pair cable.

CMOS

CMOS stands for Complimentary Metal-Oxide Semi-Conductor

Controller Area Network

A computer network protocol designed for the heavy equipment and automotive environment that allows microcontrollers and other devices to communicate with each other without using a host computer; also known as CAN.

controller I/O board

A development product that allows users to test products on a bench in a development environment before installing the product on a vehicle.

controller module

Any module that has embedded software used for controlling input and output functions.

current feedback

A circuit that allows software to measure the amount of current provided by the outputs. This circuit is typically connected to an analog input that is connected to the microprocessor. Note that current feedback is also known as current sense or current sensing.

current feedback control

Varying the duty cycle of an output so the output provides a desired amount of current to the load.

current sensing

When an analog input reads the amount of current flowing through an output driver circuit.

D**Data Link Adaptor (DLA)**

A development tool that connects the CAN bus to a personal computer (through a USB or RS232 port), so that programming and diagnostics can be performed on the product before installing it in a vehicle.

DC-coupled

A circuit used with signals that have minimal DC offset. The signal being read by this circuit must fall within the detection threshold range specified for the input.

de-rating

To reduce the rated output current level to a value less than the specified rating. De-rating is typically done so a product does not over-heat.

digital input

An input that is typically controlled by an external switch that makes the input either active (on), or inactive (off).

dimension

Selecting value(s) to generate optimal results.

driver (hardware)

An electronic device that switches power or ground to an external load. The driver is a key component used in all output circuits.

driver (software)

A block of software that provides access to different hardware components.

F**Field Effect Transistor (FET)**

An electronic device used either as a power switch, or amplifier in electronic circuitry. FETs are typically used as drivers.

floating input

An input that does not resist being pulled high or low when inactive.

frequency input

An input that allows a frequency value to be read from an oscillating input signal.

G**gain**

Increasing the voltage level of an input signal to maximize the resolution of an input.

general purpose input

An input that can be used as an analog, digital, or frequency input.

ground shift

The difference in ground potential from one harness location to another, which is typical in systems with large wire harnesses and high current loads.

H**half-bridge**

When a high-side and low-side switch are used together to provide a load with both a battery voltage and a ground.

harness address pins

Pins used by the product to identify itself within a system.

H-bridge

A combination of two half-bridge circuits used together to form one circuit. H-bridges provide current flow in both directions on a load, allowing the direction of a load to be reversed.

high-side output

An output that provides switched battery voltage to an external load.

I**inductive load**

A load that produces a magnetic field when energized. Inductors are electrical components that store energy and are characterized by the following equation:

$$E_{\text{stored}} = \frac{1}{2}LI^2$$

L**ladder logic**

A type of software code that can be used to control the product. Ladder logic is written using the VMMS tool.

load

Any component that draws current from the module, and is typically switched “on” and “off” with outputs. Examples include bulbs, solenoids, motors, etc.

logic power

Power pins for the microprocessor and logic peripherals.

low-side output

An output that provides a switched ground voltage to an external load.

M**multiplexing**

Transmitting multiple messages simultaneously over one channel in a local area network.

O**open load**

A fault state that occurs when a load that should be connected to an output becomes disconnected, which typically occurs because of a broken/worn wire in the wire harness or a broken/worn connector pin.

over-current

A fault state that occurs when a load draws more current than specified for an output, which results in the output shutting down to protect the circuitry of the product.

over-voltage

When the voltage exceeds the normal operating voltage of the product, which results in the VMM0604 shutting down to protect its circuitry.

P**power control input**

A digital input that is used to turn on the product. When the input is active, the product "turns on" and operates in normal mode, and when the input is inactive, the product "powers down" and will not operate.

procurement drawing

A mechanical drawing showing the dimensions, pin-outs, and implemented configuration options for a Parker Vansco product.

Proportional Integral Differential (PID)

This refers to the proportional-integral-differential closed-loop control algorithm.

pull-down

A resistor that connects an input to a ground reference so that an open circuit can be recognized by the microprocessor, which is typically used on active-high digital inputs or analog inputs.

pull-up

A resistor that connects an input to a voltage reference so that an open circuit can be recognized by the microprocessor, which is typically used on active-low digital inputs or analog inputs.

pulse counting

The act of counting the number of pulses that occur over a certain period of time on a frequency input.

Pulse Width Modulation (PWM)

A type of square wave frequency signal where the ratio of “on” time vs. “off” time is determined by the duty cycle of the signal. The duty cycle refers to the percent of time the square wave is “on” vs. “off”. PWM signals are typically used to drive varying amounts of current to loads, or to transmit data.

Q**quadrature**

A shaft rotation monitoring technique that provides the speed/position, and direction of the shaft.

R**RS232**

An inexpensive type of serial communication used on most PC and laptop computers that doesn't define the communication protocol, making it attractive for embedded applications. RS232 is an older technology that is slowly being phased out of production in favor of USB.

S**sample rate**

The rate at which the microprocessor reads analog voltage levels.

sensor power

A regulated voltage output that provides a set voltage level for analog sensors attached to the product.

shielded twisted-pair cable

A type of cable used for CAN communication that consists of two wires (CAN High and CAN Low) twisted together. These wires are covered by a shield material (CAN Shield) that improves the cable's immunity against electrical noise.

short-to-battery

A fault state that occurs when an input or output pin on the product is connected to battery power, potentially resulting in high current flow.

short-to-ground

A fault state that occurs when an input or output pin on the product is connected to system ground, potentially resulting in high current flow.

switch outputs

An output that is digital in nature. It switches to battery and/or ground levels.

system noise

Electrical interference generated from external devices that affect the behaviour of inputs, outputs and sensors. System noise can be generated from things like the vehicle alternator, engine, transmission, etc.

T**trip time**

The amount of time it takes a circuit to protect itself after a fault occurs.

V**VMM**

Vansco Multiplexing Module

VMM system

A collection of multiplexing products that function together in a system through software.

VMMS

Vansco Multiplexing Module Software.

W**wetting current**

The amount of current that flows into, or out of, a digital input. The current helps eliminate oxidation on the contacts of digital switches and relays. Switches with gold or silver contacts typically require much less wetting current than standard tinned contacts.

17. Index

A

- AC-coupled • 72
- AC-Coupled Frequency Input Capabilities • 23
- AC-Coupled Frequency Input Configuration Options • 24
- AC-Coupled Frequency Input Installation Connections • 24
- active-high • 72
- active-low • 72
- Addressing Digital Input Capabilities • 30
- Addressing Digital Input Connections • 30
- Addressing Digital Inputs • 29
- aliasing • 72
- amplified • 72
- analog input • 72
- Analog Input Capabilities • 20
- Analog Input Configuration Options • 20
- Analog Input Installation Connections • 21
- anti-alias filtering • 72
- Appendix A • 66
- Application Examples • 51, 68
- application software • 72
- attenuation • 72

B

- black box • 73

C

- CAN • 73
- CAN High • 73
- CAN Low • 73
- CAN Shield • 73
- CMOS • 62, 73
- Communication • 44, 68
- Connect the VMM0604 to a Development System • 15
- Connecting the Vehicle Harness to the VMM0604 • 50
- Connecting Various Sensors • 57, 69
- Connector Pin-outs • 46
- Connectors • 46
- Controller Area Network • 73
- Controller Area Network (CAN) • 44
- controller I/O board • 73
- controller module • 73
- Controlling a Linear Actuator • 56
- Controlling a Proportional Valve • 54
- Controlling Indicator Lights • 52
- Controlling Motor Speed • 55
- Create and Download Ladder Logic Software Applications • 16
- current feedback • 73
- current feedback control • 74
- current sensing • 74

D

- Data Link Adaptor (DLA) • 74
- DC-coupled • 74
- Vansco Multiplexing Module (VMM) 0604**

DC-Coupled Frequency Input Capabilities • 25
DC-Coupled Frequency Input Configuration Options • 26
DC-Coupled Frequency Input Installation Connections • 26
de-rating • 74
Designing the Vehicle Harness • 50
Diagram Conventions • 11
digital input • 74
Digital Input Capabilities • 18
Digital Input Configuration Options • 18
Digital Input Installation Connections • 19
Digital Inputs • 18, 28
dimension • 74
driver (hardware) • 74
driver (software) • 74

E

Electrical Guidelines • 50
Environmental Requirements • 49, 68

F

Field Effect Transistor (FET) • 74
floating input • 74
frequency input • 74
Frequently Asked Questions (FAQ) • 68

G

gain • 75
Gather Required Materials • 13
general purpose input • 75
General Purpose Inputs • 17
General Purpose Used as AC-Coupled Frequency Input • 23
General Purpose Used as Analog Input • 19
General Purpose Used as DC-Coupled Frequency Input • 25
General Purpose Used as Programmable Digital Input • 18, 28
ground shift • 75

H

half-bridge • 75
harness address pins • 75
H-bridge • 75
high-side output • 75
High-Side Output Capabilities • 32
High-Side Output Diagnostics and Fault Protection • 32, 34
High-Side Output Installation Connections • 33
How to Use this Manual • 11

I

Implementing Safety Interlocks • 51
inductive load • 75
Input LEDs • 39
Inputs • 17
Install the Data Link Adaptor (DLA) Driver Software • 14
Install the Required Software Tools • 14
Installing a VMM0604 into a Vehicle • 48
Introduction • 6

J

J1939 CAN Capabilities • 44
J1939 CAN Installation Connections • 44
Vansco Multiplexing Module (VMM) 0604

L

ladder logic • 75
load • 75
Logic and Output Power • 40
Logic and Output Power Capabilities • 40
Logic and Output Power Installation Connections • 41
logic power • 75
low-side output • 76
Low-Side Outputs with Current Sense Capabilities • 35
Low-Side Outputs with Current Sense Configuration Options • 37
Low-Side Outputs with Current Sense Installation Connections • 37
Low-Side Outputs with Diagnostics and Fault Protection • 37

M

Mating Connector Part Numbers • 46
Mechanical Guidelines • 48
Mechanical Requirements • 49
Mounting the VMM0604 to a Vehicle • 50
multiplexing • 76

N

Network LED • 39

O

Open Collector • 58
open load • 76
Open Load • 35
Output LEDs • 39
Outputs • 32
over-current • 76
Over-Current • 38
Overview • 13
over-voltage • 76

P

Potentiometer (Ratiometric) • 62
Power • 40, 68, 70
Power Control Digital Input • 28
Power Control Digital Input Capabilities • 28
Power Control Digital Input Installation Connections • 29
power control input • 76
Power LED • 39
Power Up the Development System • 16
Precautions • 7
procurement drawing • 76
Programmable Digital Inputs • 28
Proportional Integral Differential (PID) • 76
pull-down • 76
pull-up • 76
pulse counting • 77
Pulse Width Modulation (PWM) • 77

Q

quadrature • 77
Quick Start • 13

R

RS232 • 77

S

sample rate • 77
Selecting a Mounting Location • 48
sensor power • 77
Sensor Power • 42, 69
Sensor Power Capabilities • 42
Sensor Power Fault Responses • 43
Sensor Power Installation Connections • 43
shielded twisted-pair cable • 77
Short Circuit • 34
Short-Circuit • 38
short-to-battery • 77
Short-to-Battery • 35
short-to-ground • 77
Short-to-Ground • 38
Startup • 64
Switch • 60
switch outputs • 77
system noise • 78

T

trip time • 78
Troubleshooting • 71

U

Understanding the VMM0604 • 9
Using one Analog Input as Two Digital Inputs • 55

V

Variable Reluctance • 59
Variable Resistance • 58
VMM • 78
VMM system • 78
VMM0604 Diagnostic LEDs • 39
VMM0604 Dimensions • 48
VMM0604 High-Side Outputs • 32
VMM0604 Low-Side Outputs with Current Sense • 35
VMMS • 78
Voltage • 61

W

wetting current • 78