



Bulletin HY30-3309-INST/EU



Visit our homepage for additional support
parker.com/pmde

Installation and start-up information Hydraulic Pumps Series GPA-GP1

Effective: September 26, 2017
Supersedes: November 22, 2016



GPA



GP1

**Important installation information
for truck gear pumps**

**Wichtige Installationsinformationen
für LKW-Zahnradpumpen**

**Informations importantes pour l'installation
Pompes à engrenages pour camions**

**Important installation
information
for truck gear pumps**

**Wichtige Installations-
informationen
für LKW-Zahnradpumpen**

**Informations importantes
pour l'installation Pompes à
engrenages pour camions**

Content	Page	Inhalt	Seite	Contenu	Page
1)Flow vs. shaft rotation.....	3	1)Durchfluß- und Wellen-	3	1)Sens du débit en fonction du sens de rotation.....	3
2)Suction fitting selection.....	4	2)Verwendung der richtigen Sauganschlüsse.....	4	2)Choix du raccord d'aspiration....	4
3)Lubricate the spline.....	4	3)Schmierung der Pumpenwelle	4	3)Lubrification des cannelures	4
4)No external shaft loads	5	4)Keine äußeren Wellen- belastungen.....	5	4)Pas d'effort sur l'arbre	5
5) Hydraulic fluid.....	6	5) Hydraulikflüssigkeit.....	6	5) Fluide hydraulique	6

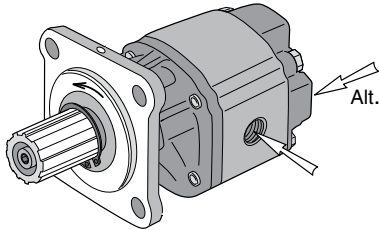
Installation and start-up information**Series GPA and GP1****Important installation information for truck gear pumps****Wichtige Installationsinformationen für LKW-Zahnradpumpen****Informations importantes pour l'installation Pompes à engrenages pour camions****1) Flow vs. shaft rotation****1) Durchfluß- und Wellendrehrichtung****1) Sens du débit en fonction du sens de rotation**

Type GPA

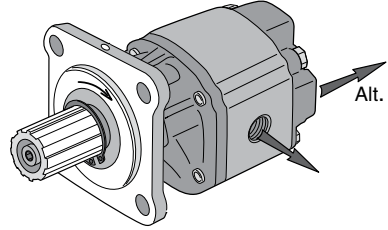

Type GPA

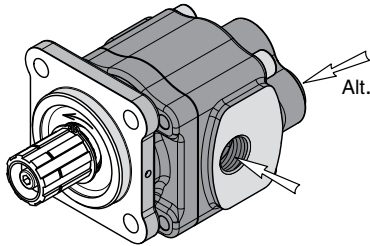

Type GP1

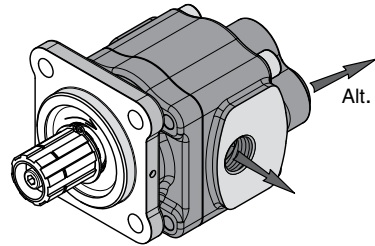

Type GP1

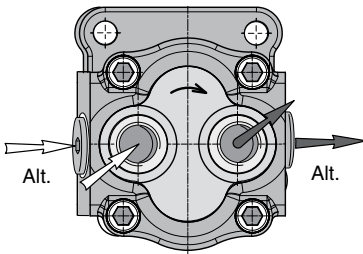

Type GPA

Left hand rotating pump
Linksdrehende Pumpe
Pompe rotation gauche

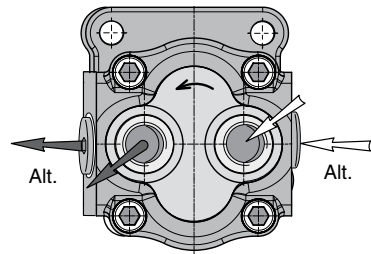

Type GPA

Right hand rotating pump
Rechtsdrehende Pumpe
Pompe rotation droite

Please note!

- The gear pumps are bi-directional (and internally drained)
- Port connector assembly:
- Screw in the connector until it firmly touches the pump housing; then tighten the connector 30° (1/12 turn).

Bitte beachten!

- Die Zahnradpumpen sind für beide Drehrichtungen vorgesehen (die Leckölabfuhr ist intern)
- Montage der Ölanschlüsse:
- Ölanschlüsse mit Schrauben an das Pumpengehäuse handfest montieren, dann die Schrauben 30° (1/12 Umdrehung) anziehen.

Veuillez noter!

- Ces pompes sont bi-directionnelles (avec drain interne)
- Montage du raccord sur l'orifice:
- Visser le raccord jusqu'au contact avec le corps de la pompe puis serrer fermement d'1/12 de tour (30 degrés).

Installation Dimensions

Series GPA and GP1

Important installation information for truck gear pumps	Wichtige Installationsinformationen für LKW-Zahnradpumpen	Informations importantes pour l'installation Pompes à engrenages pour camions
---	---	---

2) Suction fitting selection	2) Verwendung der richtigen Sauganschlüsse	2) Choix du raccord d'aspiration
------------------------------	--	----------------------------------

Flow Flow speed [m/s] at indicated line size [mm/in]

Fördermenge Durchflussgeschwindigkeit [m/s] bei den angegebenen Leitungsabmessungen [mm/zoll]

Débit Vitesse d'écoulement [m/s] pour la dimension indiquée [mm/pouce]

[l/min]	19 / 3/4"	25 / 1"	32 / 1 1/4"	38 / 1 1/2"	50 / 2"
5	0.3	0.2	0.1	< 0.1	< 0.1
15	0.9	0.5	0.3	0.2	0.1
25	1.5	0.8	0.5	0.4	0.2
40	-	1.4	0.8	0.6	0.3
60	-	2.0	1.2	0.9	0.5
80	-	-	1.7	1.2	0.7
100	-	-	-	1.5	0.8

Please note!

The gear pump must not be installed more than 0.5 m above the min. oil level in the reservoir.

Bitte beachten!

Die Pumpe muß nicht mehr als 0,5 m über dem Ölstand im Tank montiert werden.

Veillez noter!

La pompe à engrenages doit être installée au maximum 0,5 m au dessus du niveau mini du reservoir.

3) Lubricate the spline

3) Schmierung der Pumpenwelle

3) Lubrification des cannelures

Please note!

When the PTO has a sealed-off output sleeve (as shown in the illustration), the gear pump shaft spline **must be lubricated with a heat-resistant grease before start-up**; repeat periodically (at least once a year).

Bitte beachten!

Wenn der Nebenantrieb eine abgedichtete Abtriebsmuffe hat (siehe Abbildung), muss die Vielkeilwelle der Zahnradpumpe **vor Inbetriebnahme mit einem hitzebeständigen Schmierfett geschmiert werden**; mehrfach periodisch, mindestens einmal im Jahr.

Veillez noter!

Quand la prise de mouvement (PTO) possède son propre joint d'étanchéité (comme montré sur l'illustration), l'arbre cannelé de la pompe **doit être monté avec une graisse résistant à la température**; cette opération doit être répétée périodiquement.

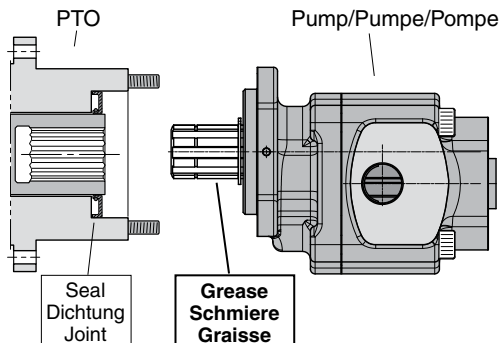

Important installation information for truck gear pumps	Wichtige Installationsinformationen für LKW-Zahnradpumpen	Informations importantes pour l'installation Pompes à engrenages pour camions
4) No external shaft loads	4) Keine äußeren Wellenbelastungen	4) Pas d'effort sur l'arbre

Please note!

- No external radial or axial shaft loads are allowed on the pump shaft.
- In case of radial and/or axial shaft loads an external, bearing supported coupling must be utilized.

Bitte beachten!

- Die Pumpenwelle darf nicht radial oder axial belastet werden.
- Im Falle von radialen und/oder axialen Wellenbelastungen ist eine separate Lagerabstützung erforderlich.

Veillez noter!

- Les efforts radiaux ou axiaux sur l'arbre de la pompe ne sont pas autorisés.
- En cas d'efforts radiaux et/ou axiaux ils doivent être supportés par des roulements.

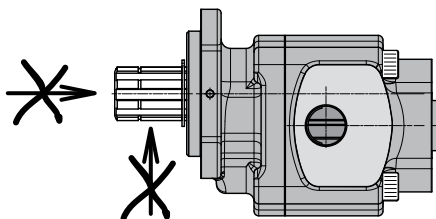

Notes / Notizen / Notes**5) Hydraulic fluid**

Use, exclusively, good quality hydraulic fluid with anti-foam and anti-wear additives.

The fluid must meet the following specifications:

DIN 51 524 / 51 525 (type HLP).

Viscosity

Acceptable:

- 8 – 800 cSt (mm²/s)

Recommended:

- 22 cSt (in cold climate)

- 37 cSt (in temperate climate)

- 46 cSt (in hot climate)

Temperature

- Min. - 15 °C

- Max.+ 80 °C

- Cold start: -25 °C to -15 °C
(< 20 bar, < 1 500 rpm)

Filtration

- Suction line: Not recommended

- Pressure line: 10 to 25 µm.

5) Hydraulikflüssigkeit

Es dürfen nur hochwertige Hydraulikflüssigkeiten auf Mineralbasis verwendet werden.

Zulässig sind HLP-Hydrauliköle nach DIN 51 524 / 51 525.

Viskosität

Zulässige Viskosität:

- 8 – 800 cSt (mm²/s)

Empfohlene Viskosität:

- 22 cSt (bei kalter Umgebungstemperatur)

- 37 cSt (normaler Umgebungstemperatur)

- 46 cSt (heißer Umgebungstemperatur)

Temperatur

- min. - 15 °C

- max.+ 80 °C

- Kaltstart: -25 °C bis -15 °C
(< 20 bar, < 1 500 U/min)

Filterung

- Saugleitungsfilter vermeiden

- Druck- oder Rücklaufilter:
10 bis 25 µm.

5) Fluide hydraulique

Utiliser exclusivement un fluide hydraulique de bonne qualité avec additifs anti-mousse et anti-usure.

Le fluide doit être conforme aux normes DIN 51 524 / 51 525 (type HLP).

Viscosité

Acceptable:

- 8 à 800 cSt (mm²/s)

Recommandé

- 22 cSt (climat froid)

- 37 cSt (climat tempéré)

- 46 cSt (climat chaud)

Température

- Mini - 15°C

- Maxi + 80°C

- Démarrage à froid:

-25°C à -15°C
(inf à 20 bar et inf à
1500 tr/mn)

Filtration

- Aspiration : non recommandée

- Pression : 10 à 25 µm.



WARNING – USER RESPONSIBILITY

FAILURE OR IMPROPER SELECTION OR IMPROPER USE OF THE PRODUCTS DESCRIBED HEREIN OR RELATED ITEMS CAN CAUSE DEATH, PERSONAL INJURY AND PROPERTY DAMAGE.

This document and other information from Parker-Hannifin Corporation, its subsidiaries and authorized distributors provide product or system options for further investigation by users having technical expertise.

The user, through its own analysis and testing, is solely responsible for making the final selection of the system and components and assuring that all performance, endurance, maintenance, safety and warning requirements of the application are met. The user must analyze all aspects of the application, follow applicable industry standards, and follow the information concerning the product in the current product catalogue and in any other materials provided from Parker or its subsidiaries or authorized distributors.

To the extent that Parker or its subsidiaries or authorized distributors provide component or system options based upon data or specifications provided by the user, the user is responsible for determining that such data and specifications are suitable and sufficient for all applications and reasonably foreseeable uses of the components or systems.

Offer of Sale

Please contact your Parker representation for a detailed "Offer of Sale".

Position notification regarding Machinery Directive 2006/42/EC:

Products made by the Pump & Motor Division Europe (PMDE) of Parker Hannifin are excluded from the scope of the machinery directive following the "Cetop" Position Paper on the implementation of the Machinery Directive 2006/42/EC in the Fluid Power Industry.

All PMDE products are designed and manufactured considering the basic as well as the proven safety principles according to:

- ISO 13849-1:2015
- SS-EN ISO 4413:2010

so that the machines in which the products are incorporated meet the essential health and safety requirements.

Confirmations for components to be proven component, e. g. for validation of hydraulic systems, can only be provided after an analysis of the specific application, as the fact to be a proven component mainly depends on the specific application.

Dr. Hans Haas

General Manger

Pump & Motor Division Europe

**Parker Hannifin Manufacturing Sweden AB** HY30-3309-INST/EU

Pump & Motor Division Europe

461 82 Trollhättan

Sweden

Tel. +46 (0)520 40 45 00

www.parker.com/pmde© Copyright 2017
All rights reserved