

# Oilgear

PVK OPEN LOOP PUMPS

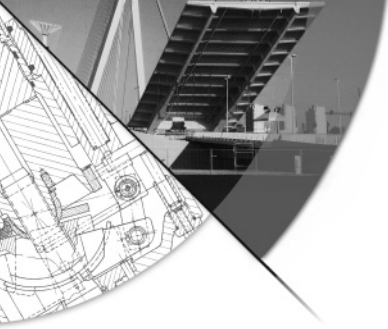



# Table of Contents

Performance Assurance	page <b>3</b>
Features and Benefits	page <b>4-5</b>
Specifications	page <b>6</b>
Pump Controls	page <b>7</b>
Curves	
Performance	page <b>8</b>
Sound	page <b>9</b>
Inlet Suction/Supercharge	page <b>10</b>
How To Order	page <b>11</b>

## PERFORMANCE ASSURANCE – STANDARD WITH EVERY OILGEAR PUMP



**Oilgear**  
PERFORMANCE  
ASSURANCE

**Every** Oilgear product is shipped to you with our Performance Assurance — a corporate commitment to stay with your installation until our equipment performs as specified.

Hydraulic equipment and systems have been Oilgear's primary business since 1921. For decades, we have developed hydraulic techniques to meet the unique needs and unusual fluid power problems of machinery builders and users worldwide, matching fluid power systems to a tremendous range of applications and industries. Our exclusive Performance Assurance program is built upon that strong foundation.

As a customer, you also benefit from access to Oilgear's impressive technical support network. You'll find factory trained and field-experienced application engineers on staff at every Oilgear facility. They are backed by headquarters staff who can access the records and knowledge learned from decades of solving the most difficult hydraulic challenges.

When your design or purchase is complete, our service is just beginning. If you ever need us, our Oilgear engineers will be there, ready to help you with the education, field service, parts and repairs to assure that your installation runs smoothly — and keeps right on running.

**Oilgear** Performance Assurance

# PVK Open Loop Pumps

Control interchangeability.

- Facilitates changes, from stock, on the machine in the field.

1

Cylinder mounted polymerous journal bearings.

- Enables operation with low viscosity or other special fluids.
- Provides infinite bearing life.
- Permits compact design.

2

Optional minimum volume stop.

4

Quiet valve plate design.

- Minimizes noise at typical electric motor speeds.

5

Thru-shaft availability.

- 100% thru-shaft capability. (PVK 140 only; PVK 270/370 is 50%)
- Enables multiple pump installation from a single shaft.
- Permits pump to drive auxiliary devices.

6

7

Hardened cylinder surface running on hardened valve plate ("hard-on-hard").

- Provides greater resistance to contamination.
- Facilitates long life.
- Allows operation with low viscosity or other special fluids.

Steel shoes running on hardened swashblock surface.

- Facilitates a higher degree of contaminate resistance.
- Permits higher pressure operation with long life.
- Allows operation with low viscosity or other special fluids.

8

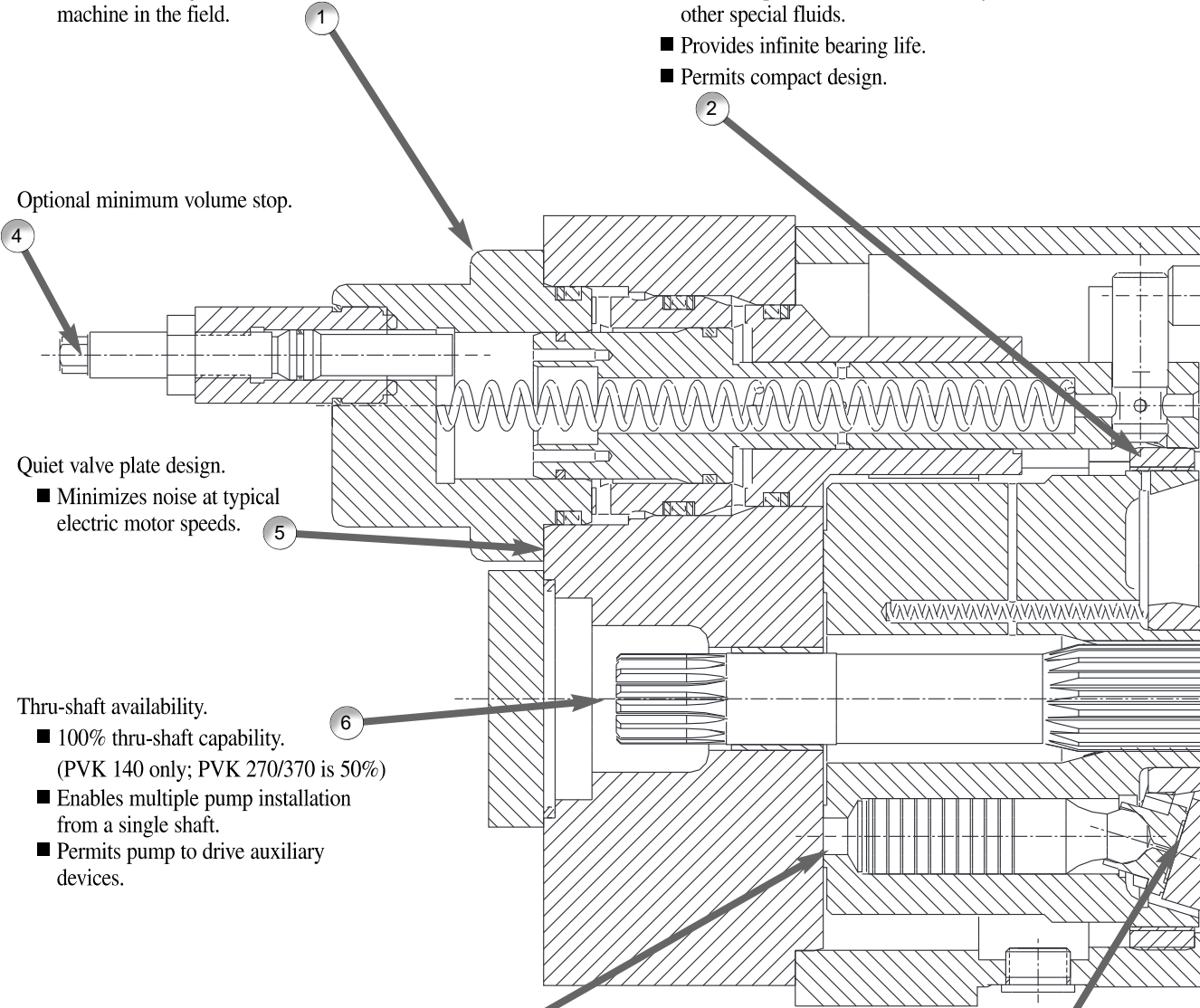

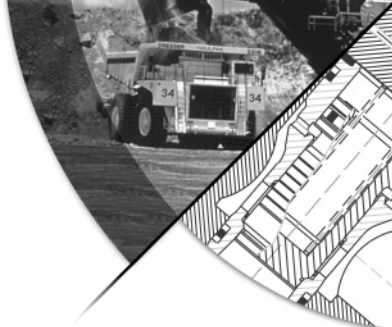

# Oilgear Features and Benefits

Swashblock and saddle with special polymerous bearings.

- Allows running on low viscosity or other special fluids.
- Permits consistent control reaction.
- Eliminates troublesome yoke bearings.
- Provides long life.

3

9

Maximum volume stop (standard).

11

Sealed front shaft bearings.

- Allows operation with low viscosity or other special fluids.
- Permits side loading.

12

SAE keyed or SAE splined shaft.

10

Patented pressure lubricated swashblock design.

- Provides high performance for high pressure cycling operation.

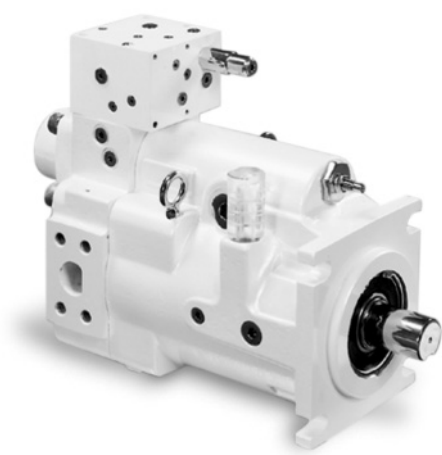
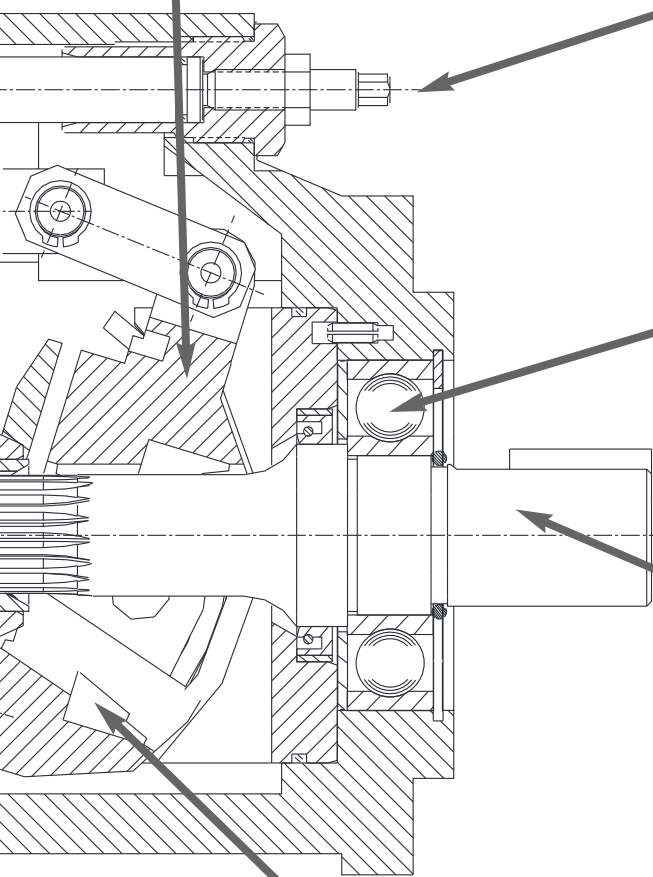

# SPECIFICATIONS

## NOMINAL DIMENSIONS

UNIT SIZE	LENGTH		WIDTH		HEIGHT		WEIGHT		FACE MOUNTING FLANGE
	in.	mm.	in.	mm.	in.	mm.	lbs.	kg.	
140	14.81	376,2	8.25	209,6	10.78	273,8	200	91	SAE "D" 4 Bolt
<b>270 &amp; 370</b>	21.25	539,8	11.75	298,5	15.69	398,5	550	250	SAE "F" 4 Bolt

## NOMINAL PERFORMANCE SPECIFICATIONS

UNIT SIZE	THEORETICAL MAXIMUM DISPLACEMENT		RATED CONTINUOUS PRESSURE		MAXIMUM PRESSURE 10% of duty cycle		MAXIMUM RATED SPEED*	FLOW RATE at max. rated rpm, rated cont. pressure & 14.7 psia (1 bar abs) inlet conditions		POWER INPUT at rated cont. pressure & max. rated rpm	
	in <sup>3</sup> /rev	ml/rev	psi	bar	psi	bar		rpm	gpm	l/min	hp
140	8.61	141	5000	345	5800	400	1800	63.0	238,7	207.2	154,6
270	16.3	267	5000	345	5800	400	1500	100.0	379,0	326.9	244,0
370	22.4	367	3500	241	4100	283	1500	135.1	512,0	324.5	242,2

\*Higher operating speeds may be approved. Consult the Oilgear application engineering department.

## PORT CONFIGURATION

Shaft Rotation	Left Hand (CCW)	Right Hand (CW)
Port A left side facing shaft	Pressure	Suction
Port B right side facing shaft	Suction	Pressure

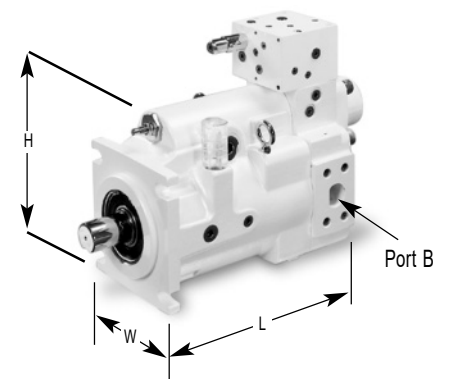

# PUMP CONTROLS

## ■ Electronic Servo Control “V”

A precision servo control designed to minimize hysteresis is available with several electro-hydraulic servo valve sizes to provide slow or very fast response rates.

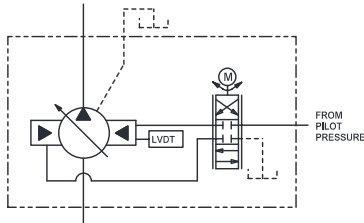

## ■ Pressure Proportional Displacement Control “E”

The control is designed with a spring feedback so that the pump will go to a stroke setting in response to a separate pressure signal. A pressure unloading option is available.

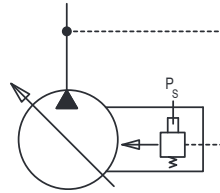

## ■ Solenoid Operated Dual Position “RU”

Two adjustable deliveries as selected by an integral solenoid operated valve.

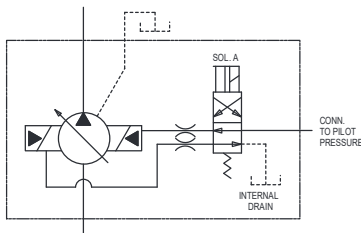

## ■ Multiple Pressure Operators

One, two or three pressure adjusting operators can be added to the basic “P” Control. The operator can be selected by integral solenoid valves and will provide independent pressure adjustment.

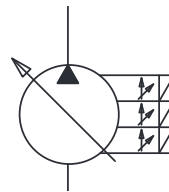

## ■ Basic Pressure Compensating Control “P”

The use of a four-way valve spool in the signal circuit allows this Oilgear Control to be adjusted to lower minimum operating pressures than other manufacturers. The Control is developed in a modular configuration facilitating the addition of multiple operators. An auxiliary port for remote pressure signal is included. A pressure compensating function is included with any of the following operators.

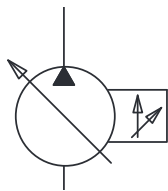

## ■ Flow Compensating Operator

A module can be added to allow the pressure compensator to operate in response to the differential pressure across an orifice – changing the operator to a flow compensator control.

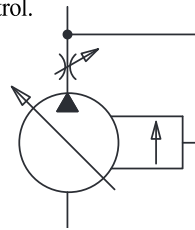

## ■ Electronically Modulated Pressure Operator

A proportional valve can be added to the basic “P” Control to regulate the compensating pressure. This operator can be used singularly or in conjunction with a pressure operator.

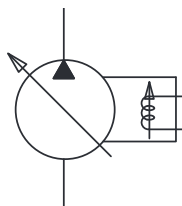

## ■ Horsepower Limiting Operator

A module can be added to all of the previously mentioned pressure sensing options to provide a control that limits horsepower as related to pump delivery.

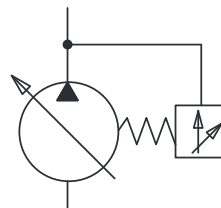

Note: Numerous “P” control/operator combinations are listed under “How-to-Order”. Please consult the factory if you have a specific requirement.

# PERFORMANCE CURVES

## Oilgear Performance Curves

### PVK-140

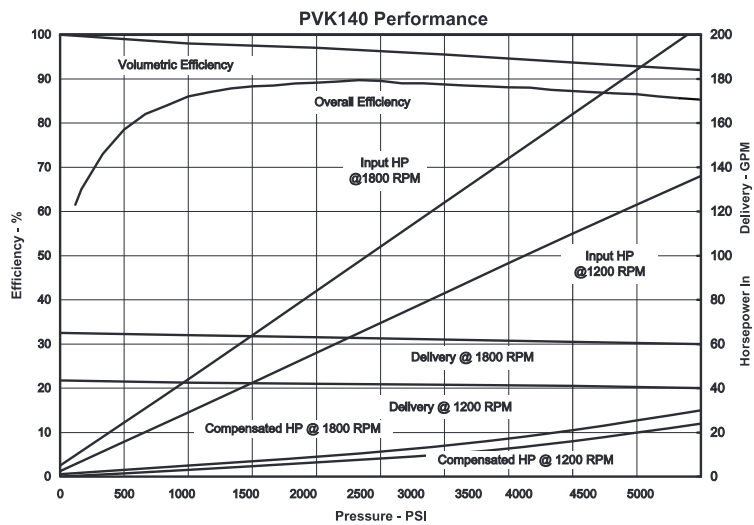

### PVK-270

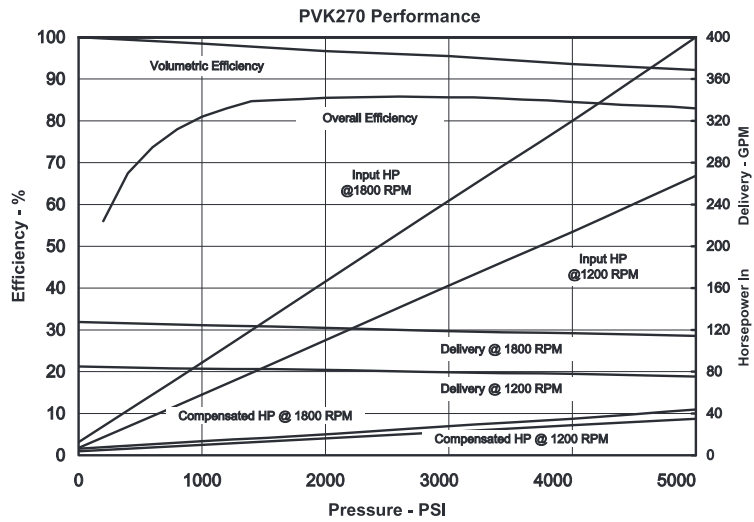

### PVK-370

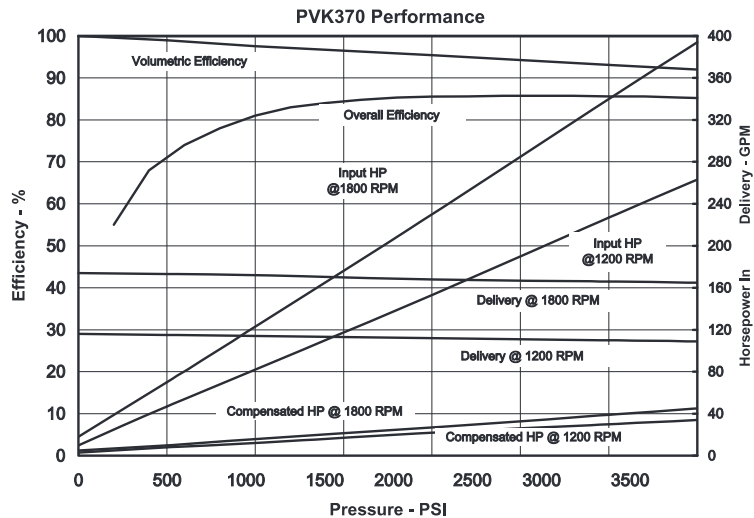

# SOUND CURVES

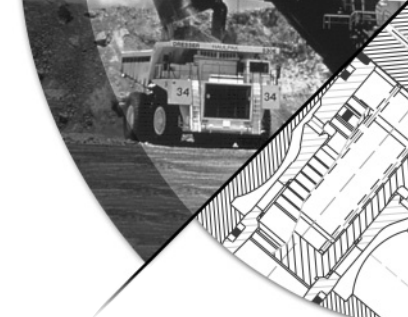

## ■ PVK-140 NOISE @ 3 ft.

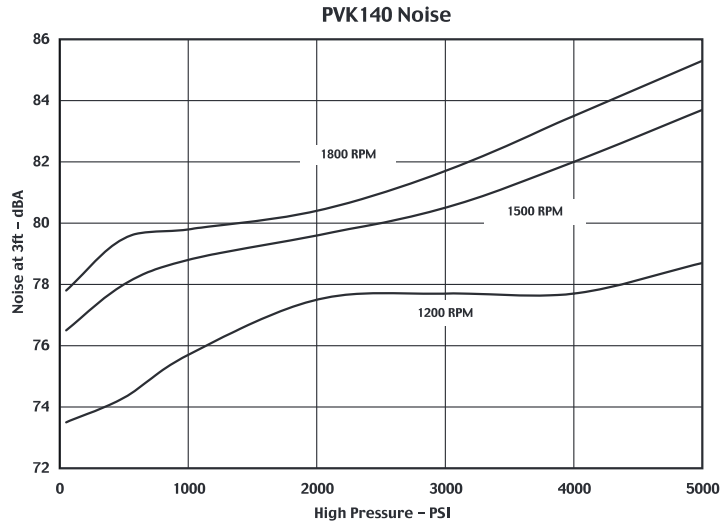

## ■ PVK-270 NOISE @ 3 ft.

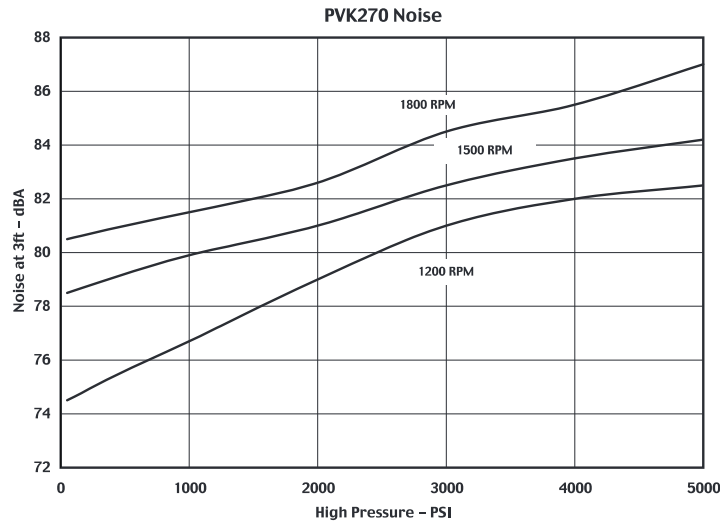

## ■ PVK-370 NOISE @ 3 ft.

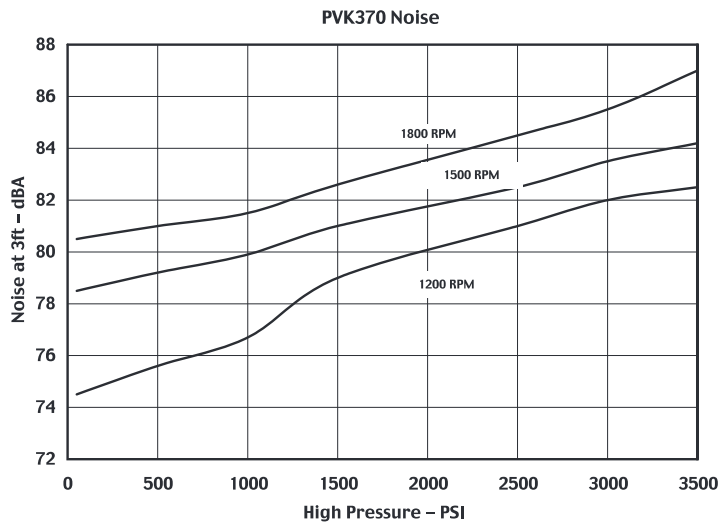

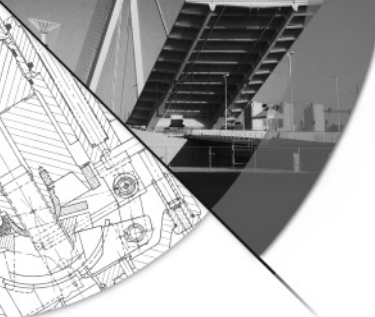

# PERFORMANCE CURVES

## Oilgear Inlet Suction Curves

■ PVK-140 SUCTION TEST

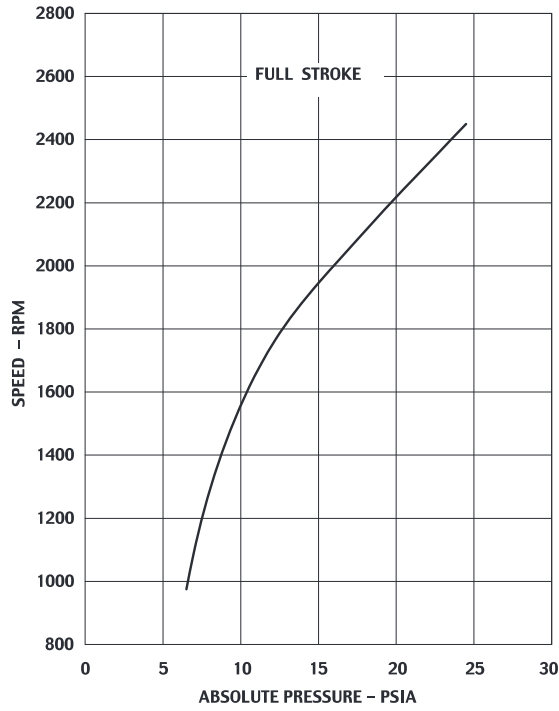

■ PVK-270 SUCTION TEST

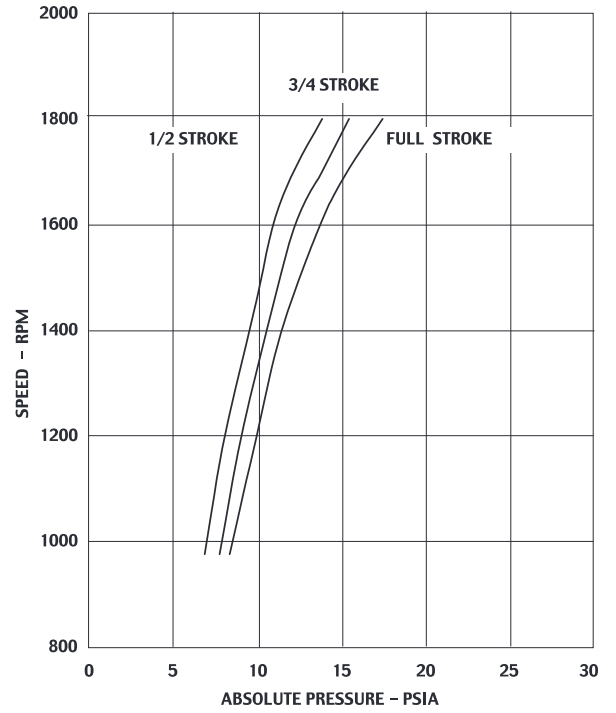

■ PVK-370 SUCTION TEST

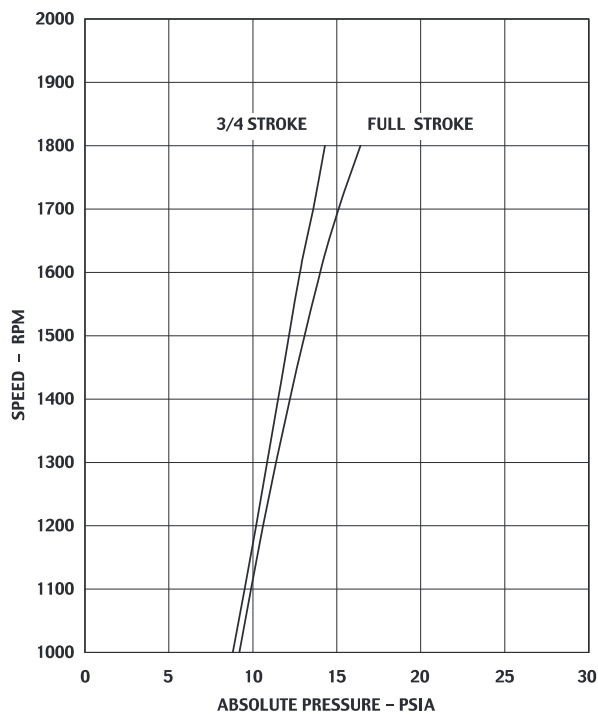

# HOW TO ORDER

BLOCK NUMBER EXPLANATION	1	2	3	-	4	-	5	6	7	-	8	9	10	11	-	12	-	13	14	-	15	/	16
VARIABLE PUMP EXAMPLE	P	V	K	-	270	-	B1	U	V	-	L	D	F	Y	-	E	-	RNN	SN	-	GS	/	51
FIXED PUMPS EXAMPLE	P	V	K	-	140	-	A1	U	V	-	L	D	F	S	-	F	-	100	SB	-	CP		
	P	F	K	-	140	-	A1	U	V	-	L	D	F	S	-	N	-	NN		-	CP		

- 1 = UNIT  
P = Pump
- 2 = TYPE  
V = Variable  
F = Fixed
- 3 = DESIGN TYPE  
K = Type
- 4 = UNIT SIZE  
140 = 140 ml/revolution  
270 = 270 ml/revolution  
370 = 370 ml/revolution
- 5 = DESIGN SERIES  
A1 = (PVK - 140)  
B1 = (PVK - 270 & 370)  
(Subject to change)
- 6 = DESIGN SERIES MODIFIER  
U = SAE Mounting and Ports  
B = Metric Threads w/BSPP Ports (PVK-140)
- 7 = SEALS  
V = Viton (Std.)  
B = Buna - N  
E = Butyl  
P = EPR
- 8 = ROTATION  
L = Left hand (CCW)  
R = Right hand (CW)
- 9 = VALVE PLATE TYPE  
D = One-Way Service  
T = Two-Way Service
- 10 = CONNECTION TYPE  
F = Flange  
(Flanges are customer supplied)
- 11 = SHAFT END  
Y = Keyed  
S = Splined
- 12 = CONTROL TYPE  
& 13 = MODIFIER  
12 =  
E = Proportional Pilot Signal Displacement Control
- 13 -1 = Type:  
A = Normally Open Proportional Device  
B = Normally Closed Proportional Device  
R = Remote (Customer Supplied Proportional Device)  
1 = Solenoid Operated, One Volume  
2 = Solenoid Operated, Two Volume  
3 = Solenoid Operated, Three Volume  
4 = Solenoid Operated, Four Volume

12	-	13
E	-	R N N

- 13 - 2 = Solenoid Voltage:  
N = None Required  
0 = 115/60 - 110/50 VAC  
1 = 230/60 - 220/50 VAC  
2 = 12 VDC  
3 = 24 VDC
- 13 - 3 = Connector:  
N = None Required  
R = .500 NPT w/o Light  
W = .500 NPT w/Light  
S = PG-11 w/o Light  
L = PG-11 w/Light
- 12 =  
F = Fixed Control

12	-	13
F	-	100

- 13 -1 = Stroke Type:  
075 = 75% Stroke  
100 = Full Stroke
- 12 =  
N = No Control

12	-	13
N	-	NNN

- 13 -1 = Type:  
NNN = No Control
- 12 =  
P = Pressure Compensating Control

12	-	13
P	-	1 N N / H 100

- 13 -1 = Pressure Compensator Options:  
1 = Single  
2 = Dual  
3 = Triple  
A = Normally Open Proportional Device  
B = Normally Closed Proportional Device  
C = Single Pressure w/No Load Starting  
D = Dual Pressure w/No Load Starting  
E = Triple Pressure w/No Load Starting  
R = Remote
- 13 - 2 = Solenoid Voltage:  
N = Non Required  
0 = 115/60 - 110/50 VAC  
1 = 230/60-220/50 VAC  
2 = 12 VDC  
3 = 24 VDC
- 13 - 3 = Connector:  
N = Non Required  
R = .500 NPT w/o Light  
W = .500 NPT w/Light  
S = PG-11 w/o Light  
L = PG-11 w/Light

- (Omit if not required)
- 13 - 4 = Control Modifier:  
F = Load Sense Option  
G = Load Sense w/Horsepower Limiting Option  
H = Horsepower Limiting Option
- 13 - 5 = Input Horsepower:  
100 = 100 HP Input @ 1800 rpm
- 12 =  
R = Solenoid Operated Volume Control

12	-	13
R	-	U 2 R

- 13 - 1 = Type:  
U = Two Volume Control
- 13 - 2 = Solenoid Voltage:  
0 = 115/60 - 100/50 VAC  
1 = 230/60 - 220/50 VAC  
2 = 12 VDC  
3 = 24 VDC
- 13 - 3 = Connector:  
R = .500 NPT w/o Light  
W = .500 NPT w/Light  
S = PG-11 w/o Light  
L = PG-11 w/Light  
B = .500 NPT Conduit Box
- 12 =  
V = Electrohydraulic (w/feedback) Control

12	-	13
V	-	S25

- 13 - 1 = Type:  
M20 = Servo Valve Size 20  
M40 = Servo Valve Size 40 (PVK-270/370 only)  
S25 = Servo Valve Size 25  
S50 = Servo Valve Size 50 (PVK-270/370 only)  
RNN = Remote Valve Control
- 14 = VOLUME STOPS  
SN = Maximum Volume Stop (Standard)  
SB = Minimum & Maximum Volume Stop
- 15 = COVER PLATE OR ADAPTERS  
CP = Cover Plate, (Standard without Auxiliary Pump)  
\*AS = Short Adapter for Mounting PVWH-04, 06, 10 (SAE A 2-Bolt)  
\*BS = Short Adapter for Mounting PVWH-11, 15, 20 (SAE B 2-Bolt)  
\*CS = Short Adapter for Mounting PVWH-25, 34, 45, 60 (SAE C 2-Bolt)  
AL = Long Adapter for Mounting PVWH-04, 06, 10 (SAE A 2-Bolt)  
BL = Long Adapter for Mounting PVWH-11, 15, 20 (SAE B 2-Bolt)  
CL = Long Adapter for Mounting PVWH-25, 34, 45, 60 (SAE C 2-Bolt)  
\*GS = Short Adapter for Mounting 51 Gear Pump (SAE B 2-Bolt)  
GL = Long Adapter for Mounting 51 Gear Pump (SAE B 2-Bolt)  
\* See DS-47927 for Adapter Mounting Limitations
- 16 = OPTIONAL AUXILIARY PUMPS  
51 = Gear Pump 5.10 cipr (85 ml/revolution) (2000 psi)  
31 = Gear Pump 3.10 cipr (51 ml/revolution) (2000 psi)

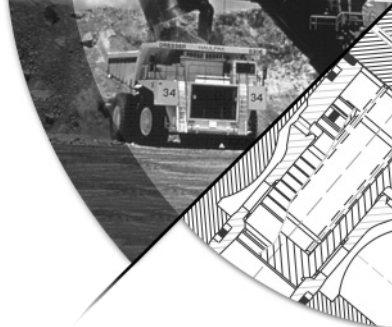

# Oilgear How to Order

# Oilgear

World Headquarters  
The Oilgear Company  
2300 South 51st Street Milwaukee, WI USA 53219  
phone: 414/327-1700 fax: 414/327-0532  
[www.oilgear.com](http://www.oilgear.com)

For more information about your application or the products  
in this brochure, please contact your nearest Oilgear facility.



AUSTRALIA  
Oilgear Towler Australia Pty. Ltd.

BRAZIL  
Oilgeardo Brazil Hydraulica Ltd.

CANADA  
The Oilgear Company

FRANCE  
Oilgear Towler S.A.

GERMANY  
Oilgear Towler GmbH

INDIA  
Oilgear Towler Polyhydron Pvt. Ltd.  
Towler Automation Pvt. Ltd.

ITALY  
Oilgear Towler S.r.l.

JAPAN  
The Oilgear Japan Company

KOREA  
Oilgear Towler Korea Co. Ltd.

MEXICO  
Oilgear Mexicana S.A. de C.V.

SPAIN  
Oilgear Towler S.A.

TAIWAN  
Oilgear Towler Taiwan Co. Ltd.

UNITED KINGDOM  
Oilgear Towler Ltd.

UNITED STATES OF AMERICA  
The Oilgear Company

