

# Enrange PGT Transmitter

---

Remote Equipment Control

---



**MAGNETEK**  
E N R A N G E

March 2013  
Part Number: 178-01636-0110 R5  
© 2013 Magnetek Material Handling

# Your New Radio Remote

---

Thank you for your purchase of Magnetek's Enrange® brand PGT Radio Remote Equipment Control. Magnetek has set a whole new standard in radio-remote performance, dependability, and value with this unique new line of handheld transmitters.

If your product ever needs modification or service, please contact one of our representatives at the following locations:

## U.S. Service Information

For questions regarding service or technical information contact:

**1.866.MAG.SERV**  
**(1.866.624.7378).**

### World Headquarters:

Magnetek, Inc.  
N49 W13650 Campbell Drive  
Menomonee Falls, WI 53051

**Telephone:** 1.800.288.8178  
**Website:** [www.magnetekmobilehydraulic.com](http://www.magnetekmobilehydraulic.com)  
**e-mail:** [info@magnetekmh.com](mailto:info@magnetekmh.com)

### Fax Numbers:

*Main:* 1.800.298.3503  
*Sales:* 1.262.783.3510  
*Service:* 1.262.783.3508

Magnetek, Inc. has additional satellite locations for Canada and the United States. For more information, please visit <http://www.magnetekmobilehydraulic.com>.

©2013 MAGNETEK

All rights reserved. This notice applies to all copyrighted materials included with this product, including, but not limited to, this manual and software embodied within the product. This manual is intended for the sole use of the person(s) to whom it was provided, and any unauthorized distribution of the manual or dispersal of its contents is strictly forbidden. This manual may not be reproduced in whole or in part by any means whatsoever without the expressed written permission of MAGNETEK.

# TABLE OF CONTENTS

1.0	INTRODUCTION .....	5
1.1	PRODUCT MANUAL SAFETY INFORMATION .....	5
1.2	WARNINGS AND CAUTIONS .....	6
2.0	CRITICAL INSTALLATION CONSIDERATIONS .....	7
2.1	GENERAL .....	7
2.2	PERSONS AUTHORIZED TO OPERATE RADIO CONTROLLED MACHINERIES .....	7
2.3	SAFETY INFORMATION AND RECOMMENDED TRAINING FOR RADIO CONTROLLED EQUIPMENT OPERATORS .....	8
2.4	TRANSMITTER UNIT .....	9
2.5	PRE-OPERATION TEST .....	9
2.6	HANDLING BATTERIES.....	10
2.7	OPTIONAL RECHARGEABLE BATTERY CHARGING .....	10
2.8	BATTERY DISPOSAL.....	10
3.0	PGT TRANSMITTER STANDARD CONFIGURATION AND OPERATION .....	11
3.1	INSTALLING THE BATTERY PACK .....	12
3.1.1	Alkaline Battery Pack (BT127).....	12
3.1.2	Optional NiMH Rechargeable Battery Pack (BT126) .....	13
3.1.3	Setting Battery Type Dip Switches .....	14
3.2	TURNING THE TRANSMITTER ON AND OFF.....	15
3.2.1	Turning On the Transmitter (with Standard Status LED Indicator).....	15
3.2.2	Turning On the Transmitter (with Optional Graphic User Interface Screen) .....	15
3.2.3	Pulling In the Machine Stop Relay.....	16
3.2.4	Turning Off the Transmitter.....	16
3.3	MACHINE STOP SWITCH (For Emergency Stopping Only).....	16
3.4	STATUS LED .....	16
3.5	OPTIONAL GRAPHIC USER INTERFACE .....	16
3.6	NORMAL OPERATING MODE WITH STANDARD STATUS LED .....	17
3.6.1	Watch Dog Indicator (Steady Blinking Status LED).....	17
3.6.2	Switch Change Indicator (Rapidly Blinking Status LED) .....	17
3.6.3	Low Battery Level Indicator (Blinking Red Status LED) .....	17
3.7	NORMAL OPERATING MODE WITH OPTIONAL GRAPHIC USER INTERFACE .....	18
3.7.1	Watch Dog Indicator (Spinning Arrow) .....	18
3.7.2	Command Confirmation .....	18
3.7.3	Battery Life Indicator .....	18
3.7.4	Signal Strength Indicator .....	18
3.7.5	Two-Way Feedback System .....	19
3.8	JOYSTICKS AND PADDLES/LEVERS .....	19
3.9	ROTARY SELECTOR SWITCH .....	19
3.10	AUXILIARY SWITCHES.....	19
4.0	TRANSMITTER SETUP .....	20
4.1	TRANSMITTER SETUP SETTINGS WITH STANDARD STATUS LED .....	20
4.1.1	RF Channel Setting Override.....	20
4.1.2	RF Channel Setting Selection.....	20
4.1.3	IR Configuration Receiver.....	22
4.1.3.1	IR Configuration Receiver On Transmitters Equipped with Separate Power/Status and Battery LED Indicators .....	22
4.1.3.2	IR Configuration Receiver On Transmitters Equipped with Single Status/Battery LED Indicator .....	23
4.2	USING THE TRANSMITTER IN SETUP MODE (WITH OPTIONAL GRAPHIC USER INTERFACE).....	24
4.2.1	Entering Setup Mode .....	24
4.2.2	Adjusting Settings in Setup Mode.....	24
4.2.2.1	Access Code.....	24

Enrange PGT Transmitter Instruction Manual

March 2013

Page 3 of 45

4.2.2.2	Channel Select .....	25
4.2.2.3	User Code.....	25
4.2.2.4	Transmitter Timeout.....	25
4.2.2.5	Backlight Timeout .....	25
4.2.2.6	Password Enable.....	26
4.2.2.7	Change Password .....	26
4.2.2.8	IR Configuration Receiver .....	26
4.2.2.9	Exit Without Save .....	27
4.2.2.10	Exit With Save .....	27
5.0	OPTIONAL PROGRAMMING WITH RCP.....	28
5.1	ACCESS CODES.....	28
5.2	CHANGING RECIEVER ACCESS CODES.....	28
5.3	CONNECTING THE PGT TO A COMPUTER .....	29
5.4	PROGRAMMING WITH RCP .....	30
5.4.1	PGT Configuration Pages.....	32
5.4.2	Saving, Downloading, and Reading the Programs and Other RCP Software Functions.....	37
6.0	TRANSMITTER CHANNEL CONFIGURATION SETTINGS .....	39
6.1	FCC STATEMENTS.....	39
6.2	CHANNEL AND FREQUENCY DESIGNATIONS BY COUNT.....	40
6.3	OPTIONAL FREQUENCIES AND CHANNELS .....	41
6.3.1	900 MHz: FHSS .....	41
6.3.2	2.4 GHz: FHSS .....	41
6.3.3	433 MHz Telemotive Legacy Channel Set: TMS and TDMA .....	41
7.0	OPTIONAL CAN BUS TETHER FEATURE .....	42
7.1	INSTALLATION OF TETHER CABLE .....	42
7.2	OPERATION OF TRANSMITTER IN TETHER MODE .....	42
7.3	RETURNING TRANSMITTER TO WIRELESS MODE .....	42
7.4	CAN CONNECTOR RECEPTACLE PIN-OUT DETAILS .....	43
8.0	GENERAL TROUBLESHOOTING .....	44
8.1	TROUBLESHOOTING OPTIONAL TETHER OPERATION.....	45
8.2	ASSEMBLY AND REPLACEMENT PARTS.....	45

## 1.0 INTRODUCTION

Thank you for your purchase of Magnetek's Enrange® brand PGT Radio Remote Equipment Control. These instructions are to be used as a reference for personnel operating the Enrange® brand PGT Radio Remote Equipment Control and the equipment that this Enrange® brand PGT Radio Remote Equipment Control is attached to.

The user of these instructions should have basic knowledge in the handling of electronic equipment.

## 1.1 PRODUCT MANUAL SAFETY INFORMATION

Magnetek, Inc. (Magnetek) offers a broad range of radio remote control products, control products and adjustable frequency drives, and industrial braking systems for overhead material handling applications. This manual has been prepared by Magnetek to provide information and recommendations for the installation, use, operation and service of Magnetek's material handling products and systems (Magnetek Products). Anyone who uses, operates, maintains, services, installs or owns Magnetek Products should know, understand and follow the instructions and safety recommendations in this manual for Magnetek Products.

The recommendations in this manual do not take precedence over any of the following requirements relating to proper equipment operation:

- Instructions, manuals, and safety warnings of the manufacturers of the equipment where the radio system is used,
- Plant safety rules and procedures of the employers and the owners of facilities where the Magnetek Products are being used,
- Regulations issued by the Occupational Health and Safety Administration (OSHA),
- Applicable local, state or federal codes, ordinances, standards and requirements, or
- Safety standards and practices for the specific industry.

This manual does not include or address the specific instructions and safety warnings of these manufacturers or any of the other requirements listed above. It is the responsibility of the owners, users and operators of the Magnetek Products to know, understand and follow all of these requirements. It is the responsibility of the owner of the Magnetek Products to make its employees aware of all of the above listed requirements and to make certain that all operators are properly trained. **No one should use Magnetek Products prior to becoming familiar with and being trained in these requirements.**

## WARRANTY INFORMATION

FOR INFORMATION ON MAGNETEK'S PRODUCT WARRANTIES BY PRODUCT TYPE, PLEASE VISIT [WWW.MAGNETEKMOBILEHYDRAULIC.COM](http://WWW.MAGNETEKMOBILEHYDRAULIC.COM).

## 1.2 WARNINGS AND CAUTIONS

Throughout this document WARNING and CAUTION statements have been deliberately placed

---

to highlight items critical to the protection of personnel and equipment.

**WARNING – A warning highlights an essential operating or maintenance procedure, practice, etc. which if not strictly observed, could result in injury or death of personnel, or long term physical hazards. Warnings are highlighted as shown below:**



**CAUTION – A caution highlights an essential operating or maintenance procedure, practice, etc. which, if not strictly observed, could result in damage to, or destruction of equipment, or loss of functional effectiveness. Cautions are highlighted as shown below:**



**WARNINGS and CAUTIONS SHOULD NEVER BE DISREGARDED.**

The safety rules in this section are not intended to replace any rules or regulations of any applicable local, state, or federal governing organizations. Always follow your local lockout and tagout procedure when maintaining any radio equipment. The following information is intended to be used in conjunction with other rules or regulations already in existence. It is important to read all of the safety information contained in this section before installing or operating the Radio Control System.

## 2.0 CRITICAL INSTALLATION CONSIDERATIONS



### **WARNING**

PRIOR TO INSTALLATION AND OPERATION OF THIS EQUIPMENT, READ AND DEVELOP AN UNDERSTANDING OF THE CONTENTS OF THIS MANUAL AND THE OPERATION MANUAL OF THE EQUIPMENT OR DEVICE TO WHICH THIS EQUIPMENT WILL BE INTERFACED. FAILURE TO FOLLOW THIS WARNING COULD RESULT IN SERIOUS INJURY OR DEATH AND DAMAGE TO EQUIPMENT.

FOLLOW YOUR LOCAL LOCKOUT TAGOUT PROCEDURE BEFORE MAINTAINING ANY REMOTE CONTROLLED EQUIPMENT. ALWAYS REMOVE ALL ELECTRICAL POWER FROM THE CRANE, HOIST, LIFTING DEVICE OR SIMILAR EQUIPMENT BEFORE ATTEMPTING ANY INSTALLATION PROCEDURES. DE-ENERGIZE AND TAGOUT ALL SOURCES OF ELECTRICAL POWER BEFORE TOUCH-TESTING ANY EQUIPMENT. FAILURE TO FOLLOW THIS WARNING COULD RESULT IN SERIOUS INJURY OR DEATH AND DAMAGE TO EQUIPMENT.

THE DIRECT OUTPUTS OF THIS PRODUCT ARE NOT DESIGNED TO INTERFACE DIRECTLY TO TWO STATE SAFETY CRITICAL MAINTAINED FUNCTIONS, I.E., MAGNETS, VACUUM LIFTS, PUMPS, EMERGENCY EQUIPMENT, ETC. A MECHANICALLY LOCKING INTERMEDIATE RELAY SYSTEM WITH SEPARATE POWER CONSIDERATIONS MUST BE PROVIDED. FAILURE TO FOLLOW THIS WARNING COULD RESULT IN SERIOUS INJURY OR DEATH OR DAMAGE TO EQUIPMENT.

## 2.1 GENERAL

Radio controlled equipment operates in several directions. Quite frequently, the equipment is operated in areas where people are working in close proximity to the material handling equipment. The operator must exercise extreme caution at all times. Workers must constantly be alert to avoid accidents. The following recommendations have been included to indicate how careful and thoughtful actions may prevent injuries, damage to equipment, or even save a life.

## 2.2 PERSONS AUTHORIZED TO OPERATE RADIO CONTROLLED MACHINERIES

Only properly trained persons designated by management should be permitted to operate radio controlled equipment.

Radio controlled equipment should not be operated by any person who cannot read or understand signs, notices, and operating instructions that pertain to the equipment.

Radio controlled equipment should not be operated by any person with insufficient eyesight or hearing or by any person who may be suffering from a disorder or illness, is taking any medication that may cause loss of equipment control, or is under the influence of alcohol or drugs.

### 2.3 SAFETY INFORMATION AND RECOMMENDED TRAINING FOR RADIO CONTROLLED EQUIPMENT OPERATORS

Anyone being trained to operate radio controlled equipment should possess as a minimum the following knowledge and skills before using the radio controlled equipment.

The operator should:

- 
- have knowledge of hazards pertaining to equipment operation
  - have knowledge of safety rules for radio controlled equipment
  - have the ability to judge distance of moving objects
  - know how to properly test prior to operation
  - be trained in the safe operation of the radio transmitter as it pertains to the equipment being operated
  - have knowledge of the use of equipment warning lights and alarms
  - have knowledge of the proper storage space for a radio control transmitter when not in use
  - be trained in transferring a radio control transmitter to another person
  - be trained how and when to report unsafe or unusual operating conditions
  - test the transmitter emergency stop and all warning devices prior to operation; testing should be done on each shift, without a load
  - be thoroughly trained and knowledgeable in proper and safe operation of the equipment that utilizes the radio control
  - know how to keep the operator and other people clear of hazardous points
  - know and follow the local lockout and tagout procedures when servicing radio controlled equipment
  - know and follow all applicable operating and maintenance manuals, safety procedures, regulatory requirements, and industry standards and codes

The operator shall not:

- operate the equipment if the direction of travel or function engaged does not agree with what is indicated on the controller
- operate any damaged or malfunctioning equipment
- change any settings or controls without authorization and proper training
- remove or obscure any warning or safety labels or tags
- leave power on the radio controlled equipment when the equipment is not in operation
- operate any equipment using a damaged controller because the unit may be unsafe
- operate manual motions with other than manual power
- operate radio controlled equipment when low battery indicator is on

Enrange PGT Transmitter Instruction Manual  
March 2013  
Page 8 of 45





## WARNING

THE OPERATOR SHOULD NOT ATTEMPT TO REPAIR ANY RADIO CONTROLLER. IF ANY PRODUCT PERFORMANCE OR SAFETY CONCERNS ARE OBSERVED, THE EQUIPMENT SHOULD IMMEDIATELY BE TAKEN OUT OF SERVICE AND BE REPORTED TO THE SUPERVISOR. DAMAGED AND INOPERABLE RADIO CONTROLLER EQUIPMENT SHOULD BE RETURNED TO MAGNETEK FOR EVALUATION AND REPAIR. FAILURE TO FOLLOW THIS WARNING COULD RESULT IN SERIOUS INJURY OR DEATH AND DAMAGE TO EQUIPMENT.

### 2.4 TRANSMITTER UNIT

Transmitter switches should never be mechanically blocked ON or OFF. When not in use, the operator should turn the transmitter OFF. A secure storage space should be provided for the transmitter unit, and the transmitter unit should always be placed there when not in use. This precaution will help prevent unauthorized people from operating the material handling equipment.

Spare transmitters should be stored in a secure storage space and only removed from the storage space after the current transmitter in use has been turned OFF, taken out of the service area and secured.

### 2.5 PRE-OPERATION TEST

At the start of each work shift, or when a new operator takes control of the equipment, operators should do, as a minimum, the following steps before operation of equipment:

Test all warning devices.

**Test all direction and speed controls.**

**Test all functions**

Test the transmitter emergency stop.

## 2.6 HANDLING BATTERIES



KNOW AND FOLLOW PROPER BATTERY HANDLING, CHARGING AND DISPOSAL PROCEDURES. IMPROPER BATTERY PROCEDURES CAN CAUSE BATTERIES TO EXPLODE OR DO OTHER SERIOUS DAMAGE. FAILURE TO FOLLOW THIS WARNING COULD RESULT IN SERIOUS INJURY OR DEATH AND DAMAGE TO EQUIPMENT.

Use only batteries approved by Magnetek for the specific product.

Do not dispose of a battery pack in fire; it may explode.

Do not attempt to open the battery pack.

Do not short circuit the battery.

Keep the battery pack environment cool during storage (i.e., not in direct sunlight or close to a heating source).

## 2.7 OPTIONAL RECHARGEABLE BATTERY CHARGING

For those transmitters equipped with rechargeable batteries and battery chargers, all users shall be familiar with the instructions of the charger before attempting to use.

Do not attempt to charge non-rechargeable battery packs in the charger.

Avoid charging partially discharged rechargeable batteries to help prolong battery cycle life.

Do not charge batteries in a hazardous environment.

Keep the battery pack environment cool during charging (i.e., not in direct sunlight or close to a heating source).

Do not short the charger.

Do not attempt to charge a damaged battery.

Use only Magnetek Enrange approved chargers for the appropriate battery pack.

Do not attempt to use a battery that is leaking, swollen or corroded.

Charger units are not intended for outdoor use. Only use charger units indoors.

## 2.8 BATTERY DISPOSAL

Before disposing of batteries consult local and governmental regulatory requirements for proper disposal procedure.

### 3.0 PGT TRANSMITTER STANDARD CONFIGURATION AND OPERATION



## WARNING

BEFORE OPERATING THE TRANSMITTER, FAMILIARIZE YOURSELF WITH ALL SAFETY INFORMATION IN THIS MANUAL, THE CORRESPONDING RECEIVER SYSTEM MANUAL, APPROPRIATE MANUAL SUPPLEMENTS AND ANY OTHER LOCAL, STATE, OR FEDERAL RULES OR REGULATIONS ALREADY IN EXISTENCE. FAILURE TO FOLLOW THIS WARNING COULD RESULT IN SERIOUS INJURY OR DEATH AND DAMAGE TO EQUIPMENT.

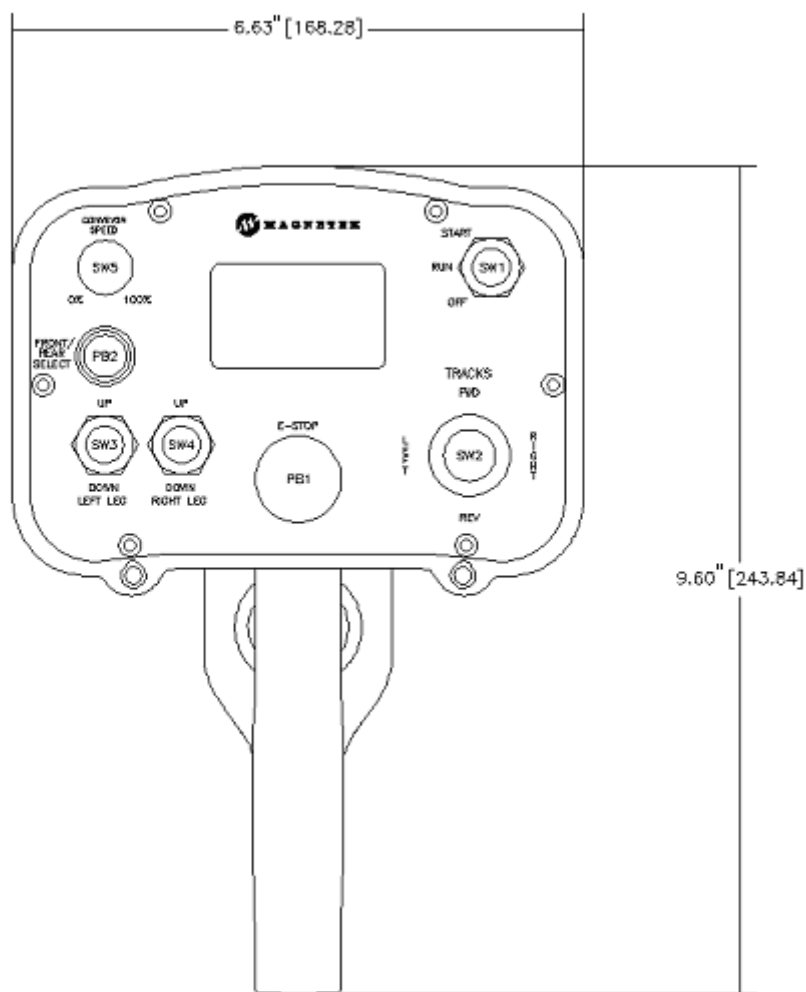

Figure 1: Typical PGT Configuration.

### 3.1 INSTALLING THE BATTERY PACK

Prior to utilizing the PGT transmitter, the battery pack must be installed (unless the unit is being utilized with the optional tether feature - then the battery pack is optional).

#### 3.1.1 Alkaline Battery Pack (BT127)

The PGT comes standard with a battery pack (BT127) that holds three disposable AA alkaline batteries.



Figure 2: BT127 Battery Pack

To change the alkaline batteries in the battery pack, separate the inner tray from the outer housing (see Figure 2) and replace all the batteries with new ones.



Figure 3: Separated Alkaline Battery Pack

When reinserting the tray into the outer housing, make sure the grooves in the inner tray align with the slides in the outer housing. When placing the battery pack into the PGT battery pocket, orient the battery pack so that the sticker is facing out (see Figure 4).



Figure 4: Installation of Battery Pack into PGT transmitter

After installing the battery pack, install the battery cover over the battery and secure by tightening the thumbscrew at the end of the battery cover (see Figure 5).



**Figure 5: Installation of Battery Cover**

*NOTE: For the battery level indicator on the PGTs equipped with either the standard status LED or the optional graphic user interface, the battery type dip switch settings need to be set for the battery pack being used in order to display the correct low battery level indication. See Section 3.1.3 for details on setting the battery type dip switches.*

### **3.1.2 Optional NiMH Rechargeable Battery Pack (BT126)**

*NOTE: If using the optional rechargeable battery pack BT126, review and become familiar with the rechargeable battery charger manual prior to use.*

The rechargeable battery pack BT126 is a sealed battery pack that has no user-serviceable components within the battery pack.



**Figure 6: BT126 Battery Pack**

The rechargeable battery pack BT126 is shipped from the factory with a minimal charge and will need to be charged prior to use for the first time with the specified charger.

*NOTE: When utilizing the optional tether mode on the PGT transmitter, the battery packs will not be recharged from the tether power feed. The rechargeable battery pack only can be recharged using the specified charger.*

When placing the battery pack into the PGT battery pocket, orient the battery pack so that the sticker is facing out (see Figure 4).

After installing the battery pack, install the battery cover over the battery and secure by tightening the thumbscrew at the end of the battery cover (see Figure 5).

*NOTE: For the battery level indicator on the PGTs equipped with the standard status LED or the optional graphic user interface, the battery type dip switch settings need to be set for the battery pack being used in order to display the correct low battery level indication. See Section 3.1.3 for details on setting the battery type dip switches.*



### 3.1.3 Setting Battery Type Dip Switches

For proper indication of the battery level on the PGT transmitters, the battery type dip switch settings need to be set for the battery pack being used in the transmitter.

*NOTE: The dip switch settings are set at the factory for the battery type ordered with the system. These settings will need to be changed only if the battery type changes.*

The dipswitches are accessed through the USB/IR cover on the bottom of the PGT transmitter (see Figure 7).



**Figure 7: USB/IR Cover Location and Cover Removal**

Use the following table to properly set the dip switches for the correct battery type (see Figure 8 for dip switch view):

Battery P/N	Battery Type	Dip Switch 1	Dip Switch 2
BT127-0	4.5V Alkaline	Off	Off
BT126-0	3.6V NiMH	Off	On



**Figure 8: Dip switch block as viewed through USB/IR port**

*NOTE: The dip switch block switches are oriented so that the Off position is next to the number designator and the On position is up or away from the number designator.*

### 3.2 TURNING THE TRANSMITTER ON AND OFF

The PGT uses both a three position toggle switch labeled OFF-ON-START and a Machine Stop switch to turn the transmitter on or off.



Figure 9: Machine Stop Switch and OFF-ON-START toggle

#### 3.2.1 Turning On the Transmitter (with Standard Status LED Indicator)

First, the Machine Stop switch must be in the raised position (pulled out). Next, push the OFF-ON-START toggle switch to the START position and release it once the Status LED lights up as a solid green color. Following the Status LED turning on and illuminating green, the unit will perform a routine initialization.

During initialization, the PGT scans for any switches or motions that may be on during power up. If any switches or motions are on, the failure will be displayed as a solid red Status LED, and the PGT will power itself down.

After a successful initialization, the PGT will enter normal operation mode and display the normal operating status LED indications. See Section 3.6 for more information on the normal operation mode with standard status LED.

#### 3.2.2 Turning On the Transmitter (with Optional Graphic User Interface Screen)

First, the Machine Stop switch must be in the raised position (pulled out). Next, push the OFF-ON-START toggle switch to the START position and release it once the Magnetek logo appears on the LCD screen. Following the logo screen, the unit will perform a routine initialization.

During initialization, the PGT scans for any switches or motions that may be on during power up. If any switches or motions are on, the failure will be displayed on the display, and the PGT will power itself down.

After a successful initialization, the PGT will enter the Normal Operation Mode and display the normal operating screen. See Section 3.7 for more information on the Normal Operation Mode with Optional Graphic User Interface.

*NOTE: Holding the OFF-ON-START toggle in the START position for more than 5 seconds will put the device into Setup Mode. For normal use release the START toggle once the Magnetek logo appears. See Section 4.2 for more information on the Setup Mode.*

Enrange PGT Transmitter Instruction Manual

March 2013

Page 15 of 45

### 3.2.3 Pulling In the Machine Stop Relay

Once the PGT has been turned on (as described in Sections 3.2.1 and 3.2.2) and in the Normal Operating Mode, the Machine Stop relay can be pulled in by pushing the OFF-ON-START toggle switch to the START position and then releasing.

*NOTE: You must release the OFF-ON-START switch to the ON position after the unit is powered up, then push to the START position a second time to pull in the Machine Stop relay.*

### 3.2.4 Turning Off the Transmitter

The transmitter can be turned off by pressing the OFF-ON-START toggle switch down to the OFF position. Once turned off, the MLC relay in the receiver is immediately opened.

*NOTE: If the unit has a standard status LED, it will illuminate a solid red color during the transmitter's power down process. Once the power down process is complete, the transmitter will turn off and the status LED will not be on.*

*NOTE: Depressing the Machine Stop switch will also turn the transmitter off and open the Machine Stop relay in the receiver. See Section 3.3 for more information on the Machine Stop switch.*

## 3.3 MACHINE STOP SWITCH (For Emergency Stopping Only)

When depressed, the Machine Stop relay in the receiver is immediately opened.

Under normal operating conditions, the Machine Stop switch must be in the raised position or the transmitter and system will not operate.

*NOTE: The Machine Stop Switch is to be used for emergency stopping only, not for normal system shut down.*

## 3.4 STATUS LED

The standard PGT transmitter includes a status LED to let the operator know that the unit is functioning and if the battery level is low.

## 3.5 OPTIONAL GRAPHIC USER INTERFACE

The optional LCD screen located at the center of the device provides visual information during the operation of the PGT transmitter. It is used to change configuration settings, confirm commands being operated, provide two-way feedback, and display transmitter diagnostic information such as battery life and signal strength.

The optional graphic user interface replaces the standard status LED when ordered.



### **3.6 NORMAL OPERATING MODE WITH STANDARD STATUS LED**

In normal operating mode, the PGT utilizes the status LED to communicate the watch dog timer within the CPU of the transmitter and when the battery level is low.

#### **3.6.1 Watch Dog Indicator (Steady Blinking Status LED)**

The blinking LED represents the watch dog timer within the CPU of the unit.

*NOTE: The LED should be continuously blinking at all times. If the LED is not blinking the transmitter will need to be rebooted to operate properly.*

#### **3.6.2 Switch Change Indicator (Rapidly Blinking Status LED)**

When a switch is actuated or a switch status changes, the status LED will blink rapidly during the change.

*NOTE: If a joystick, rotary switch or auxiliary switch is held in position or latched, the status LED will return to the steady watch dog indicator blinking state.*

#### **3.6.3 Low Battery Level Indicator (Blinking Red Status LED)**

When the battery level drops below 10% the status LED will turn red. The status LED will continue blinking for the watch dog indicator and switch change indicator status.

*NOTE: If using an optional battery pack that is different than what the unit was shipped from the factory with, the low battery level indicator will be inaccurate unless the dip switch settings are set to the correct battery type being used. See Section 3.1.3 for details to properly set the dip switches.*

### 3.7 NORMAL OPERATING MODE WITH OPTIONAL GRAPHIC USER INTERFACE

In normal operating mode, the PGT displays real time information relating to the operation of the transmitter on the graphic user interface. Information may include Command Confirmation, Battery Life, Signal Strength, Two-Way Feedback, etc.

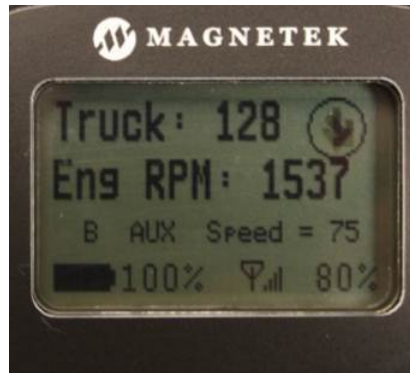

Figure 10: Normal operating screen on graphic user interface

#### 3.7.1 Watch Dog Indicator (Spinning Arrow)

The spinning arrow represents the watch dog timer within the CPU of the unit.

*NOTE: The arrow should be continuously spinning at all times. If the arrow is not spinning the transmitter will need to be rebooted to operate properly.*

#### 3.7.2 Command Confirmation

Each time the user operates a control on the transmitter, a message will be displayed on the graphic user interface screen confirming what is being operated.

For example, if the second paddle is moved to its 4th position in the UP direction the display will show 'MTN2 D1 SP=4'. This translates to 'Motion 2, Direction 1, Speed 4'.

#### 3.7.3 Battery Life Indicator

Remaining battery life is displayed in the bottom left hand corner of the graphic user interface screen.

Battery life is displayed in 5% increments.

*NOTE: If using an optional battery pack that is different than what the unit was shipped from the factory with, the battery life indicator will be inaccurate unless the dip switch settings are set to the correct battery type being used. See Section 3.1.3 for details to properly set the dip switches.*

#### 3.7.4 Signal Strength Indicator

The Signal Strength Indicator shows the radio signal strength at the receiver.

The Signal Strength Indicator is only available in systems equipped for Two-Way feedback (systems utilizing the 433 MHz frequency band do not have Two-Way feedback available). For such systems, Signal Strength is displayed at the bottom right hand corner of the graphic user interface screen.

Signal Strength is displayed in 5% increments.

*NOTE: On 433 MHz systems, the signal strength indicator will show minimum signal strength regardless of the actual signal strength (systems utilizing the 433 MHz frequency band do not have Two-Way feedback).*

### **3.7.5 Two-Way Feedback System**

This option allows the user to view various parameters that may be important to the operation of the equipment on the graphic user interface display screen.

Parameters such as engine RPM, the torque or speed of a drive, temperature, current, or any other useful values can be sent from the receiver and displayed on the transmitter.

*NOTE: Systems utilizing the 433 MHz frequency band do NOT have Two-Way feedback available.*

### **3.8 JOYSTICKS AND PADDLES/LEVERS**

To activate the desired motor functions, operate the Joystick or Paddle/Lever that corresponds to the desired motion.

To activate higher speed functions for those transmitter models so equipped, operate the Joystick or Paddle/Lever further to activate the desired speed.

### **3.9 ROTARY SELECTOR SWITCH**

The rotary selector switch can be used to select various modes of operation.

A rotary switch can have 2 to 12 positions to select from.

### **3.10 AUXILIARY SWITCHES**

These switches activate special function relays that control items such as grab attachments, magnets, lights, and etc.

The auxiliary switches can be momentary or latched.

## 4.0 TRANSMITTER SETUP

The transmitter may have settings changed one of four ways.

For units without the optional graphic user interface, the built-in dip switch block can adjust the RF channel, RF Channel Setting Override function, and the battery type. The RF channel and access code can be programmed using the IR configuration link with a compatible receiver. All other settings can only be changed at the factory or with the optional RCP software.

For units with the optional graphic user interface, the Setup Mode can be used to edit configuration settings such as: Access Code, Channel Select, User Code, Transmitter Time Out, Backlight Time Out, Password Enable, Change Password, and more. The settings can also be changed with the optional RCP software.

*NOTE: The IR configuration receiver link can adjust settings on both types of units (with and without the optional graphic user interface), but on units without the optional display the saved channel is only used if the override dip switch is set to ON. If the override dip switch is set to OFF, the dip switch settings set the RF channel.*

*NOTE: The optional RCP software can adjust settings on both types of units (with and without the optional graphic user interface) but on units without the optional display, the saved channel is only used if the override dip switch is set to ON. If the override dip switch is set to OFF, the dip switch settings set the RF channel.*

### 4.1 TRANSMITTER SETUP SETTINGS WITH STANDARD STATUS LED

There are three settings that can be adjusted using the dip switch block: the battery life indication setting, the RF Channel Setting Override setting, and the RF Channel setting. In addition, the access code and channel can be changed using the IR configuration receiver link with a compatible receiver (contact the factory to determine if your receiver is compatible).

The Battery Life Indication setting can be set for the appropriate battery type using dip switch positions 1 and 2; this is detailed in Section 3.1.3. The RF Channel Setting Override, the RF Channel Setting Selection, and the IR Configuration are detailed in the following sections.

#### 4.1.1 RF Channel Setting Override

The dip switch block can enable or disable the RF channel setting dip switch override. Dip switch position number 3 enables the channel from memory function, which enables the transmitter to utilize the channel setting that was set up with the optional RCP software in the transmitter's memory (instead of normally overwriting the channel settings with the dip switch settings in standard status LED equipped transmitters) or to use the channel that was set up using the IR configuration receiver option. This dip switch is located on the same block used for battery life indication and is visible through the USB/IR window (see Figure 11). To set the RF channel setting override, reference Figure 12 for dip switch settings for the override function.

#### 4.1.2 RF Channel Setting Selection

The dip switch block can also set the RF channel setting. This dip switch block is the same block used for RF channel setting override and battery life indication. The dip switch block is visible through the USB/IR window (see Figure 11).



**Figure 11: Dip switch block as viewed through USB/IR port**

*NOTE: The dip switch block switches are oriented so that the Off position is next to the number designator and the On position is up or away from the number designator.*

Regardless of which radio frequency the transmitter was equipped with the RF channel dip switch settings are the same. Refer to Sections 6.2 and 6.3 for details on the specific RF channel details for the radio frequency that the transmitter is equipped with.

The following figure details the dip switch positions for each RF channel.

		SWITCH POSITIONS				
CHANNEL		SW4	SW5	SW6	SW7	SW8
1		DOWN	DOWN	DOWN	DOWN	DOWN
2		UP	DOWN	DOWN	DOWN	DOWN
3		DOWN	UP	DOWN	DOWN	DOWN
4		UP	UP	DOWN	DOWN	DOWN
5		DOWN	DOWN	UP	DOWN	DOWN
6		UP	DOWN	UP	DOWN	DOWN
7		DOWN	UP	UP	DOWN	DOWN
8		UP	UP	UP	DOWN	DOWN
9		DOWN	DOWN	DOWN	UP	DOWN
10		UP	DOWN	DOWN	UP	DOWN
11		DOWN	UP	DOWN	UP	DOWN
12		UP	UP	DOWN	UP	DOWN
13		DOWN	DOWN	UP	UP	DOWN
14		UP	DOWN	UP	UP	DOWN
15		DOWN	UP	UP	UP	DOWN
16		UP	UP	UP	UP	DOWN
17		DOWN	DOWN	DOWN	DOWN	UP
18		UP	DOWN	DOWN	DOWN	UP
19		DOWN	UP	DOWN	DOWN	UP
20		UP	UP	DOWN	DOWN	UP
21		DOWN	DOWN	UP	DOWN	UP
22		UP	DOWN	UP	DOWN	UP
23		DOWN	UP	UP	DOWN	UP
24		UP	UP	UP	DOWN	UP
25		DOWN	DOWN	DOWN	UP	UP
26		UP	DOWN	DOWN	UP	UP
27		DOWN	UP	DOWN	UP	UP
28		UP	UP	DOWN	UP	UP
29		DOWN	DOWN	UP	UP	UP
30		UP	DOWN	UP	UP	UP
31		DOWN	UP	UP	UP	UP
32		UP	UP	UP	UP	UP

FUNCTION	SW3
CHANNELS FROM DIPSWITCH	DOWN
CHANNELS FROM MEMORY	UP

**Figure 12: Dip switch positions for RF channel selection**

The dip switch settings will take effect upon the next power cycle of the transmitter.

*NOTE: If using the optional RCP software on transmitters NOT equipped with the optional graphic user interface, the channel settings will read from the dip switch positions and not from memory when the channel from memory override function is not enabled. The RF channel set by the optional RCP software will not be used unless the memory override dip switch is set to ON. When the RF channel from memory override is NOT enabled, the dip switch positions set the RF channel used by the transmitter.*

*NOTE: If using the IR configuration receiver function on transmitters NOT equipped with the optional graphic user interface, the channel settings will read from the dip switch positions and not from memory when the channel from memory override function is not enabled. The RF channel set by the IR configuration receiver function will not be used unless the memory override dip switch is set to ON. When the RF channel from memory override is NOT enabled, the dip switch positions set the RF channel used by the transmitter.*

*NOTE: The transmitters equipped with the optional graphic user interface will read channel settings from memory and will not respond to dip switch changes for the channel setup. Only the dip switches for the battery life indication are functional on graphic user interface equipped transmitters.*

### **4.1.3 IR Configuration Receiver**

IR Cfg Recv function allows the transmitter to link, using IR, to a compatible receiver (contact the factory to determine if your receiver is compatible) and automatically set up the channel and access code to match the linked compatible receiver.

*NOTE: If using the IR configuration receiver function on transmitters NOT equipped with the optional graphic user interface, the channel settings will read from the dip switch positions and not from memory when the channel from memory override function is not enabled. The RF channel set by the IR configuration receiver function will not be used unless the memory override dip switch is set to ON. When the RF channel from memory override is NOT enabled, the dip switch positions set the RF channel used by the transmitter.*

#### **4.1.3.1 IR Configuration Receiver On Transmitters Equipped with Separate Power/Status and Battery LED Indicators**

To utilize the IR configuration receiver function and link to a compatible receiver, push the OFF-ON-Start toggle to the Start position and hold for more than 5 seconds. When the transmitter successfully enters the IR configuration mode, the Power/Status and Battery LED(s) will blink alternately continuously. After the LEDs are blinking alternately, point the IR window of the transmitter at the desired receiver to control and momentarily press the OFF-ON-Start toggle to the Start position and release.

If the link is successful, the LEDs will stop blinking and the transmitter will shut down. The new settings obtained from the IR configuration function will take effect upon the next power cycle of the transmitter.

If the link is unsuccessful with a compatible receiver, the Power/Status and Battery LED(s) will continue to blink alternately.

To cancel the IR configuration receiver without a successful link, move the OFF-ON-Start toggle to the OFF position.



#### **4.1.3.2 IR Configuration Receiver On Transmitters Equipped with Single Status/Battery LED Indicator**

To utilize the IR configuration receiver function and link to a compatible receiver, push the OFF-ON-Start toggle to the Start position and hold for more than 5 seconds. When the transmitter successfully enters the IR configuration mode, the Status/Battery LED will blink continuously. After the LED is blinking, point the IR window of the transmitter at the desired receiver to control and momentarily press the OFF-ON-Start toggle to the Start position and release.

If the link is successful, the LED will stop blinking and the transmitter will shut down. The new settings obtained from the IR configuration function will take effect upon the next power cycle of the transmitter.

If the link is unsuccessful with a compatible receiver, the Status/Battery LED will continue to blink.

To cancel the IR configuration receiver without a successful link, move the OFF-ON-Start toggle to the OFF position.

## 4.2 USING THE TRANSMITTER IN SETUP MODE (WITH OPTIONAL GRAPHIC USER INTERFACE)

*NOTE: The Setup Mode is only accessed on transmitters equipped with the optional graphic user interface. The units equipped with the standard status LED can only have the settings of the transmitter changed at the factory or by using the optional RCP software.*

The Setup Mode can be used to edit configuration settings such as: Access Code, Channel Select, User Code, Transmitter Time Out, Backlight Time Out, Password Enable, Change Password, and more.

*NOTE: No parameter changes will take effect until the user has selected 'Save and Exit' from the Setup Mode.*

### 4.2.1 Entering Setup Mode

To enter the Setup Mode, first make sure the unit is OFF and the Machine Stop switch is raised. Next, push the OFF-ON-START toggle switch to the START position and hold it in the START position for more than 5 seconds until the setup screen appears.

The user will see a prompt for a four digit password if the password feature is enabled. If no password is enabled, then the adjustments in Section 4.2.2 will be available with no further input required from the user.

*NOTE: The password feature is enabled by default from the factory.*

Use the Joystick/Paddle to increment/decrement the value and toggle to the START position when finished. If the password is entered correctly, the device will enter Setup Mode. If it is entered incorrectly, the device will power down.

*NOTE: The factory default password to get into the setup menu is 0000.*

### 4.2.2 Adjusting Settings in Setup Mode

To navigate through Setup Mode, the Joystick/Paddle designated (MTN 1) and OFF-ON-START switch are used. The Joystick/Paddle cycles through the menus and is also used to change parameters within the menus. Pushing the OFF-ON-START switch to the START position will toggle between the menu and its parameter(s). When adjusting larger values, the speed is dependent on how far the Joystick/Paddle is depressed.

*NOTE: No parameter changes will take effect until the user has selected 'Save and Exit' from the Setup Mode.*

#### 4.2.2.1 Access Code

The Access Code determines which receiver will be controlled by the transmitter.

The Access Code in the MLTX2 transmitter must match the receiver Access Code or dip switches.

If the Access Codes settings on the receiver and transmitter do not match, no communication will occur.

The Access Code is a 20-bit binary value with a decimal equivalent of 0 - 1048575. It will be displayed as binary or decimal depending on the application.



#### 4.2.2.2 Channel Select

The Channel Select setting determines the frequency that the MLTX2 is operating on.

The user can select channels 1-32 which correspond to the frequencies in Sections 6.2 and 6.3.

#### 4.2.2.3 User Code

The User Code setting is a unique identifier that allows the user to select multiple modes when using the same channel. The receiver can be tuned to only 'hear' messages sent from a transmitter with the same user code.

#### 4.2.2.4 Transmitter Timeout

This setting controls the amount of time that the transmitter can be inactive before it automatically shuts off.

The Timeout time can be set from 1 to 60 minutes.

When the unit times out, the transmitter will turn off.

Setting Timeout to 0 disables transmitter timeout.



DO NOT ASSUME THE POWER IS OFF IN THE RECEIVER BECAUSE THE TRANSMITTER IS TURNED OFF. FAILURE TO FOLLOW THIS WARNING COULD RESULT IN SERIOUS INJURY OR DEATH AND DAMAGE TO EQUIPMENT.

#### 4.2.2.5 Backlight Timeout

The Backlight timeout setting controls the amount of time that the backlight will stay on after a command is pressed before it automatically shuts off.

Backlight Timeout can be set from 1 to 30 seconds.

Setting Timeout to disable will disable the backlight.

Setting Timeout to "always on" sets the backlight to be on continuously while the transmitter is on and active.

*NOTE: Leaving the backlight on longer will decrease the battery run time and will require more frequent battery replacement (or recharges for optional rechargeable battery packs).*

#### 4.2.2.6 Password Enable

This setting enables or disables the requirement of entering a password into the transmitter to enter Setup Mode.

When the disabled setting is selected the user will go directly into Setup Mode without being prompted to enter a password.

Magnetek strongly recommends enabling the Setup Mode password setting to prevent unauthorized or accidental changes to parameters.

*NOTE: The unit is shipped with the password requirement enabled and utilizing the factory default password.*

#### 4.2.2.7 Change Password

This allows the user to change the password needed to enter the Setup Mode.

The password must consist of 4 digits.

#### 4.2.2.8 IR Configuration Receiver

IR Cfg Recv function in the setup allows the transmitter to link to a compatible receiver by using IR (contact the factory to determine if your receiver is compatible) and automatically set up the channel and access code to match the linked compatible receiver.

After selecting this option, point the IR window of the transmitter at the desired receiver to control and momentarily press the OFF-ON-Start toggle to the Start position and release. The graphic user interface will display "Attempting" while scanning for the receiver's IR signal. If the receiver is in range and IR link is made, the message will change to "Success".

*NOTE: The changes to the transmitter's channel configuration and access code will not be saved until the operator selects the Exit with Save option to exit the Setup Mode.*

If the receiver is not in range, the scan will time out and the graphic user interface will display "Failed". The operator can reposition the transmitter and reattempt to establish the IR link with the receiver by toggling the Start position on the OFF-ON-Start toggle multiple times.

*NOTE: The access code and channel will not be updated to match the desired receiver until "Success" is displayed. Once "Success" is displayed, subsequent "Failed" messages will not overwrite the access code and channel obtained in the successful IR link until a new successful IR link is made.*

The IR configuration function will only update channel and access code information if the receiver and transmitter are programmed at the factory with the same project identification number. If the receiver/transmitter pairing is not programmed with the same project identification number, the graphic user interface will display "Err Project ID" when an IR link is attempted. The IR link will not be successful and the access code and channel information in the transmitter will not be changed.

If the receiver and transmitter IR pair are not operating in the same frequency band, when an IR link is attempted the graphic user interface will display "Err RF Freq". The IR link will not be successful and the access code and channel information in the transmitter will not be changed.

#### **4.2.2.9 Exit Without Save**

If the user does not wish to save any of the configuration changes made, the Exit Without Save option can be selected.

*NOTE: None of the changes will be saved upon selection of this option. The transmitter will start up with the last saved configuration settings.*

#### **4.2.2.10 Exit With Save**

Selection of this option saves all changes and exits the Setup Mode.

Upon exit, the device will start up with the new configuration settings.

## 5.0 OPTIONAL PROGRAMMING WITH RCP

Using the optional RCP software makes programming of the PGT easier and allows for settings to be saved for future reference.



### WARNING

THE USE OF RCP (RADIO CONTROL PROGRAMMER) IS INTENDED FOR USE BY AUTHORIZED PERSONS ONLY. CHANGES TO ANY RADIO DATA VALUE MAY LEAD TO UNEXPECTED, UNDESIRABLE, OR UNSAFE OPERATION OF EQUIPMENT AND FURTHERMORE MAY LEAD TO EQUIPMENT DAMAGE, PERSONAL INJURY, OR EVEN DEATH. ALL EQUIPMENT OPERATORS AND/OR PERSONNEL SHOULD BE NOTIFIED OF ANY RADIO DATA VALUE CHANGES THAT MAY AFFECT OPERATION.

## 5.1 ACCESS CODES

The receiver and transmitter must be programmed with the same access code to properly communicate with each other.



### WARNING

TWO OPERATIONAL TRANSMITTERS WITH THE SAME ACCESS CODES OPERATING AT THE SAME TIME IS A DEFINITE SAFETY HAZARD. FAILURE TO FOLLOW THIS WARNING COULD RESULT IN SERIOUS INJURY OR DEATH AND DAMAGE TO EQUIPMENT.

## 5.2 CHANGING RECEIVER ACCESS CODES

**Receiver Access Code Programming.** For detailed instructions on setting parameters including access codes, see the "Programming" section of the applicable receiver manual.



### WARNING

AFTER CHANGING THE ACCESS CODES ON THE TRANSMITTER, TEST THE UNIT BY TURNING IT ON AND OFF NEAR THE APPROPRIATE RECEIVER. IF THE RECEIVER DOES NOT RESPOND, DO NOT ACTIVATE A FUNCTION BUTTON! THE TRANSMITTER MAY HAVE THE WRONG ACCESS CODE, WHICH COULD MOVE OTHER EQUIPMENT. RE-CHECK THE ACCESS CODE IN THE TRANSMITTER AND RETEST. FAILURE TO FOLLOW THIS WARNING COULD RESULT IN SERIOUS INJURY OR DEATH, AND DAMAGE TO EQUIPMENT.



## WARNING

THE ACCESS CODES IN THE RECEIVER ARE UNIQUE AND FACTORY PRESET. DO NOT CHANGE THESE ACCESS CODES UNLESS YOU ARE REPLACING AN EXISTING RECEIVER AND ITS ACCESS CODE. CHANGING THIS CODE COULD MAKE IT COMMON WITH ANOTHER RECEIVER ACCESS CODE, WHICH COULD MOVE OTHER EQUIPMENT. NO TWO SYSTEMS IN ANY LOCATION SHOULD EVER HAVE THE SAME ACCESS CODES INDEPENDENT OF THE FREQUENCY. FAILURE TO FOLLOW THIS WARNING COULD RESULT IN SERIOUS INJURY OR DEATH, AND DAMAGE TO EQUIPMENT.

### 5.3 CONNECTING THE PGT TO A COMPUTER

The PGT transmitter contains circuits that permit communication with a computer system via USB. The USB mini-B plug is located through the IR/USB port window as detailed in Section 3.1.3.

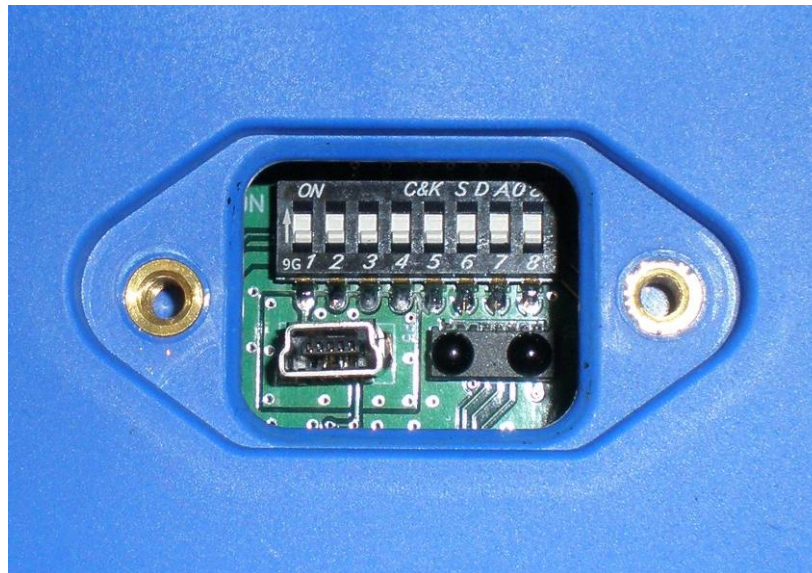

Figure 13: USB mini-B receptacle as viewed through USB/IR port

When plugging in the transmitter to a computer system, the transmitter batteries must be installed. The USB circuit does not provide power to the transmitter. Magnetek highly recommends using a fully charged battery pack when using USB and RCP with the transmitter.

## 5.4 PROGRAMMING WITH RCP

Read the section of the PGT manual regarding additional operational features to familiarize you with the features listed below. The PGT transmitter can be programmed using the optional RCP (Radio Control Programmer) software.

Magnetek RCP software makes the programming of the PGT transmitter easier and allows the programmer to store all of the PGT settings in files for later use or reference. The RCP software also allows the programmer to customize the PGT transmitter display (on PGTs with optional graphic user interface) with language descriptions that are project or machine specific. Help is provided for each function at the bottom of the RCP screen. The RCP software allows you to select frequency, access code, transmitter power, as well as CAN configuration. Follow the steps below:

### Install the RCP Software

Install the RCP software onto your computer. The software is self installing; simply insert the CD-ROM into your CD-ROM drive and follow the onscreen prompts. Refer to the installation instruction sheet for help. You will be prompted to enter an activation code. The code can be found on the CD jewel case and on the installation instructions. The software cannot be used without this code.

### Run the RCP Software

After installation of the RCP Software, double click the RCP icon to launch the program.



### Click on New Project or Open Project

Select “New Project” if you are creating a new program file. Select “Open Project” if you want to retrieve an existing program file. A list of recent projects will appear under “Open Project.” Clicking on one of these will open that project. It is recommended that you create a folder in which to save all programming files.

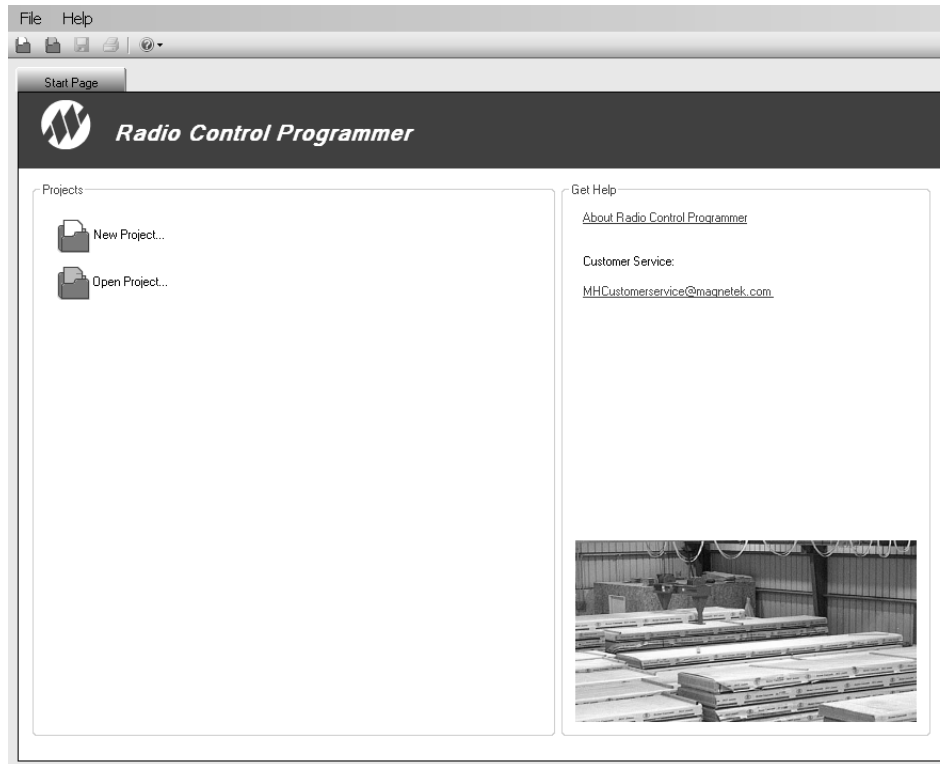

### For New Projects, Select Device Type

After the New Projects icon is selected, a menu will open listing the available device types. Select the device type that matches the product you wish to program (selecting a project type will display a picture of the product for verification).

### Receive Device Data Checkbox

At the bottom of the New Project window there is a check box that allows the user to automatically download the setting values on the device upon connection.

*NOTE: This check box is checked by default.*

Having the “Receive Device Data” option checked will cause the program to automatically read the data that is currently on the device upon clicking the Add button.



## WARNING

IF “RECEIVE DEVICE DATA” CHECKBOX IS UNCHECKED, THE RCP PROGRAM WILL OVERWRITE ALL SETTING VALUES ON THE DEVICE WITH DEFAULT VALUES AND ANY SETTINGS CHANGED BY THE OPERATOR UPON SENDING THE PROGRAM TO THE DEVICE. ALL STORED VALUE SETTINGS WITHIN THE DEVICE WILL BE REPLACED, INCLUDING ANY PROJECT-SPECIFIC VALUES. MAGNETEK STRONGLY RECOMMENDS THAT THE “RECEIVE DEVICE DATA” CHECKBOX BE LEFT CHECKED.



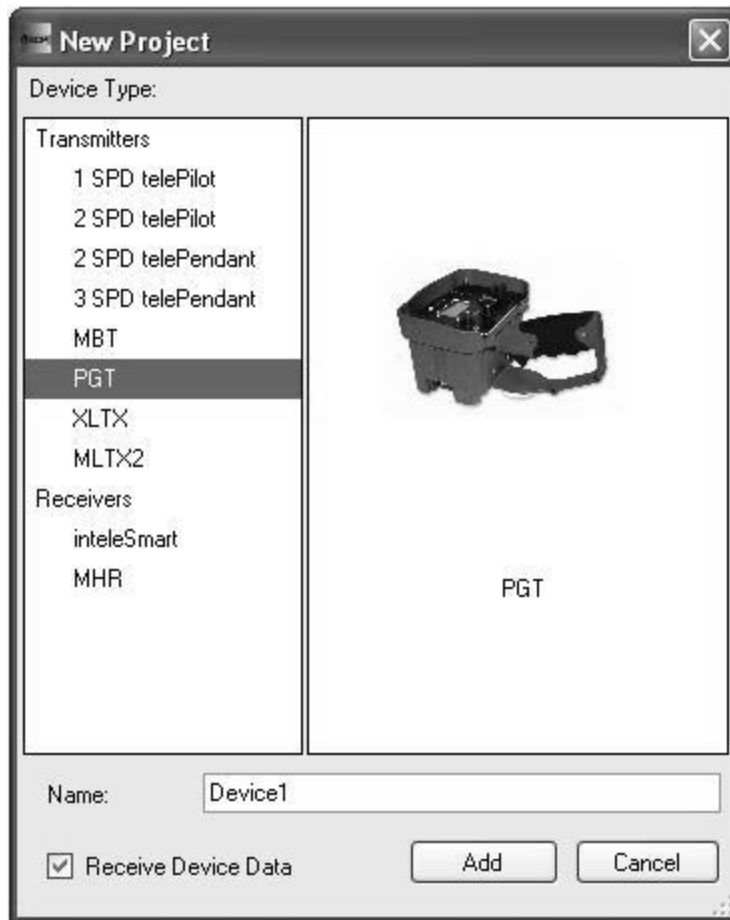

This screen also allows the programmer to create a specific name for the device to help keep track of device settings and changes. It is recommended that a unique name is chosen for each device programmed with RCP.

#### 5.4.1 PGT Configuration Pages

The PGT Transmitter has two configurable pages available to change settings on. The first page allows the configuration of general transmitter settings (Transmitter name, Access code, RF channel, etc.). The second page allows the configuration of the CAN bus network settings for models with the optional CAN connector equipped.

#### Unit Info Pages

This page allows the user to view the receiver's Project ID and serial number. The user can modify the transmitter name, access code, RF channel and activate the password. This page may also be used by the user to synchronize the internal clock on the transmitter with the connected PC or manually set the clock/date.

*NOTE: Changing any of these details will require a reboot of the PGT after the new information has been sent to the device.*



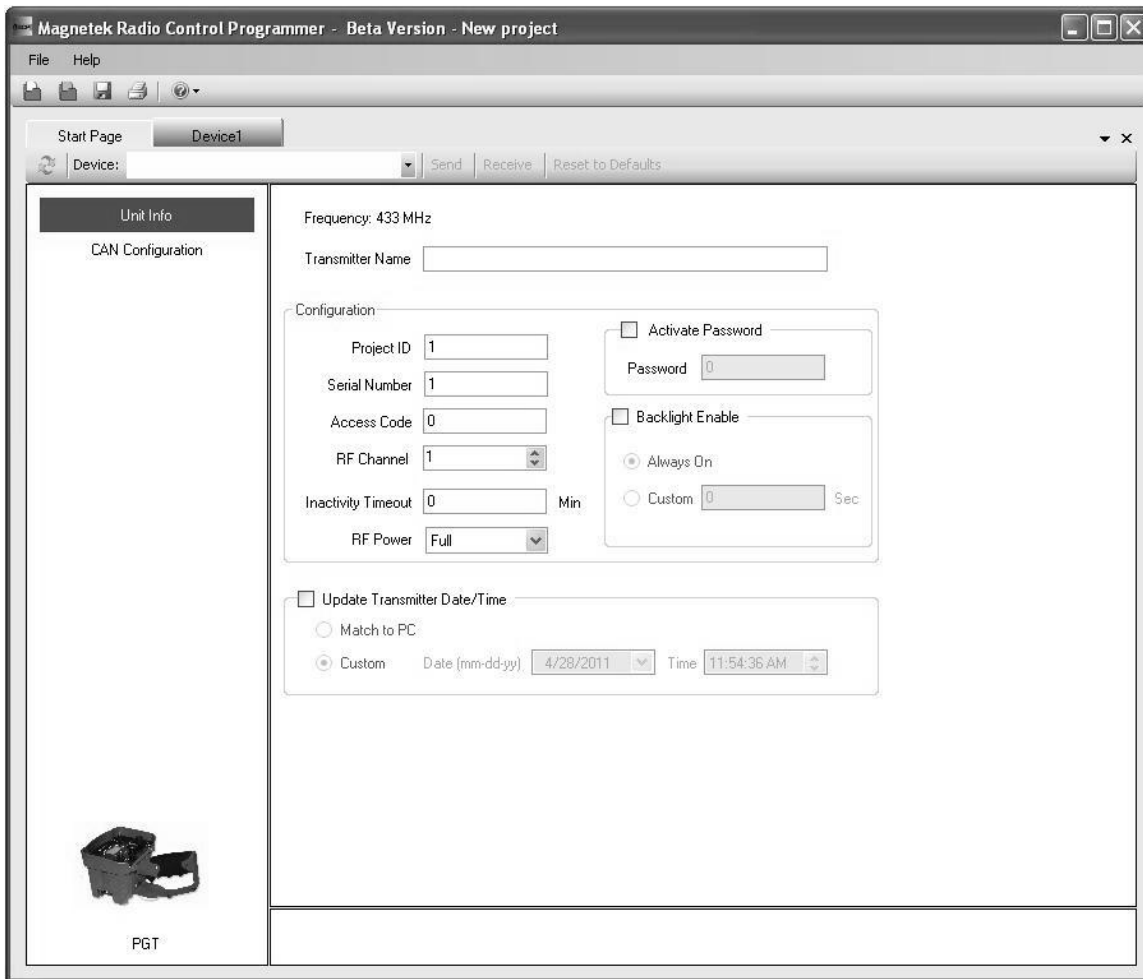

### *Transmitter Name*

The transmitter name field allows the user to create a custom name for the transmitter. The name can be up to 16 ASCII characters long.

### *Project ID*

This section displays the Project ID for the unit. The Project ID is set by the factory and cannot be modified by the user.

### *Serial Number*

This section displays the serial number for the unit. The serial number of the unit is set by the factory and cannot be modified by the user.

### Access Code

The access code acts as the transmitter address. The transmitter will only transmit commands to receivers with the same address. This feature is selectable by the user.

*NOTE: The transmitter must be set with the same access code as the receiver to properly communicate with each other.*



## WARNING

THE ACCESS CODES IN THE RECEIVER ARE UNIQUE AND FACTORY PRESET. DO NOT CHANGE THESE ACCESS CODES UNLESS YOU ARE REPLACING AN EXISTING RECEIVER AND ITS ACCESS CODE. CHANGING THIS CODE COULD MAKE IT COMMON WITH ANOTHER RECEIVER ACCESS CODE, WHICH COULD MOVE OTHER EQUIPMENT. NO TWO SYSTEMS IN ANY LOCATION SHOULD EVER HAVE THE SAME ACCESS CODES INDEPENDENT OF FREQUENCY. FAILURE TO FOLLOW THIS WARNING COULD RESULT IN SERIOUS INJURY OR DEATH, AND DAMAGE TO EQUIPMENT.

### RF Channel

The RF channel is user-selectable through the pull-down menu. This function is used to prevent interference with other radio devices. The user-selectable channels for 400 MHz, 900 MHz and 2.4 GHz systems are 1 through 32. See Sections 6.2 and 6.3 for channel frequency details.

*NOTE: If using the optional RCP software on transmitters NOT equipped with the optional graphic user interface, the channel settings will read from the dip switch positions and not from memory when the channel from memory override function is not enabled. The RF channel set by the optional RCP software will not be used unless the memory override dip switch is set to ON. When the RF channel from memory override is NOT enabled, the dip switch positions set the RF channel used by the Transmitter.*

### Inactivity Timeout

The transmitter can be set to turn off after a period of time when no controls are activated. To restart the transmitter, the OFF-ON-START switch must be cycled through the Start position. The factory default setting for the inactivity timeout is 15 minutes.

### RF Power

The RF transmitting power of the unit is user-selectable through the pull-down menu. This function is used to reduce the operating range of the transmitter from the equipment being operated. The user-selectable options for RF power are Full, Half, Quarter and Minimum.

### Activate Password

The password is used to restrict access to the configuration menu on the PGT. Having an active password prevents accidental changes to the transmitter.

**Please familiarize yourself with this section before programming your password.**

If you choose to enable the password function, you can create a new password by selecting a four digit numerical password using numbers from 0 to 9. Be sure to write this password down in a safe place for future reference.



## WARNING

ALWAYS REMEMBER TO STORE THE PASSWORD IN A SECURE LOCATION FOR ACCESS IF THE PASSWORD IS LOST OR FORGOTTEN. ONCE THE TRANSMITTER IS PROGRAMMED WITH A PASSWORD, THERE IS NO WAY TO DEFEAT THE PASSWORD WITHOUT USING THE RCP SOFTWARE TO EITHER READ THE PASSWORD OR REPROGRAM A NEW PASSWORD.



## WARNING

THIS PASSWORD FUNCTION IS NOT TO BE USED AS A SECURITY DEVICE. THE PURPOSE OF THIS FUNCTION IS TO PREVENT ACCIDENTAL CHANGES TO THE TRANSMITTER SETTINGS. THE BEST FORM OF SECURITY IS ALWAYS TO LOCK UP THE TRANSMITTER WHEN NOT IN SERVICE. FAILURE TO FOLLOW THIS WARNING COULD RESULT IN SERIOUS INJURY OR DEATH AND DAMAGE TO EQUIPMENT.

The password default setting is to be disabled during initial programming by the RCP software. To enable password protection, check the box next to the phrase "Activate password."



## WARNING

NOT ENABLING THE PASSWORD FUNCTION ALLOWS THE TRANSMITTER SETTINGS TO BE MODIFIED BY ANY UNAUTHORIZED USERS. IMPROPER TRANSMITTER SETTINGS COULD RESULT IN SERIOUS INJURY OR DEATH AND DAMAGE TO EQUIPMENT.

### *Backlight Enable*

This section allows the user to enable the LCD display backlight (on systems equipped with optional graphic user interface LCD display) and select the period of time after transmitter activity that the backlight stays on.

The user has the option to check the "Always On" check boxed for backlight timeout. If this box is checked, the backlight will remain on continuously while the transmitter is active.

*NOTE: The longer the backlight is turned on, the shorter the transmitter battery life will be.*

The user can also enable the backlight to turn off or timeout after a period of time - the user can select the custom field and enter in the time (in seconds) that the backlight should be lit. The range of values is 1 to 30 seconds.

*Update Transmitter Date/Time*

Enrange PGT Transmitter Instruction Manual

March 2013

Page 35 of 45

This feature allows the user to reset the internal clock on the transmitter to the correct date and time. The user can select to match the clock on the PC that is connected to the unit or select a custom date and time.

## CAN Configuration Page

This page allows the user to modify the CAN bus network communication settings.

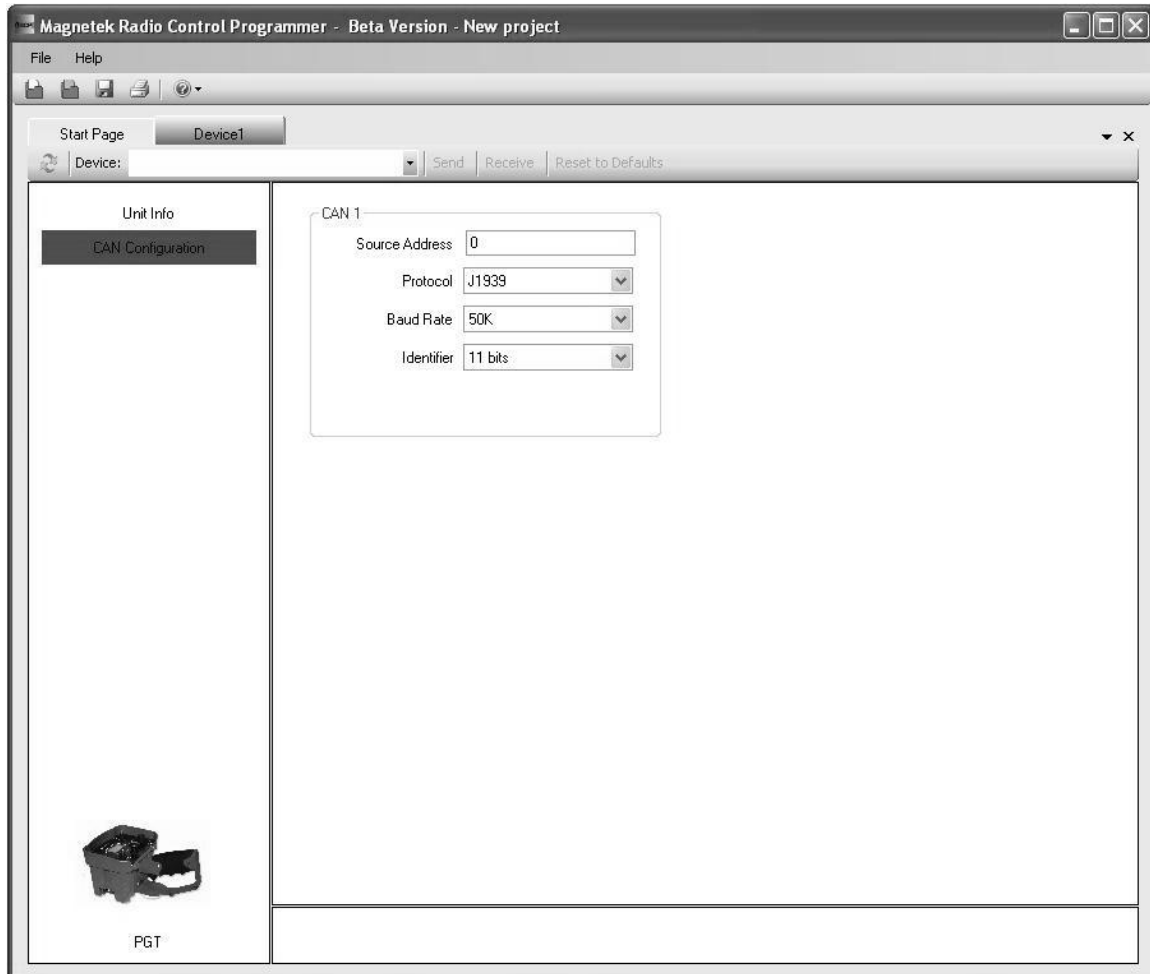

### Source Address

This is the address that the PGT will use as the source address when transmitting messages on the CAN bus network.

### *Protocol*

This pull-down menu allows the user to modify the communication protocol for the CAN bus network. The user can select from the following options:

- J1939
- CAN Open
- Parker ICP
- High Country Tek DN
- OEM Controls

### *Baud Rate*

This pull-down menu allows the user to modify the communication speed of the CAN bus network. The user-selectable options are 50k, 125k, 250k, and 500k.

### *Identifier*

This pull-down menu allows the user to select between an 11 bits or 29 bits identifier.

## **5.4.2 Saving, Downloading, and Reading the Programs and Other RCP Software Functions**



### **CAUTION**

TO PROGRAM OR READ DATA FROM THE PGT, THE TRANSMITTER MUST BE TURNED ON.

### **Saving the Programming File**

Once programming is complete click the file tab at the top of the RCP screen to open the file menu. File locations and name can be selected from this menu. Old files can be deleted, called up, modified and renamed by this same menu.

### **Sending a Program to the PGT**



### **WARNING**

AFTER EVERY PROGRAMMING OF THE TRANSMITTER, TEST THE UNIT BY UTILIZING THE APPROPRIATE RECEIVER. IF THE RECEIVER DOES NOT RESPOND, DO NOT ACTIVATE A FUNCTION BUTTON! THE TRANSMITTER MAY HAVE INCORRECT PROGRAMMING. RE-CHECK THE PROGRAMMING IN THE TRANSMITTER AND RETEST. AFTER ACTIVATION OF THE RECEIVER, FUNCTIONALLY TEST ALL COMMANDS ON THE TRANSMITTER BY INITIALLY JOGGING THE BUTTONS, THEN WITH A FULL MOVEMENT BEFORE RETURNING TO SERVICE. FAILURE TO FOLLOW THIS WARNING COULD RESULT IN SERIOUS INJURY OR DEATH AND DAMAGE TO EQUIPMENT.

### *To send a program file to a PGT Transmitter*

1. Plug in the USB programming cable or position.
2. Click the “send” button on the RCP screen. A dialog box will pop up confirming that you want to proceed. Check the box marked “I accept,” and then click the button “Continue send to radio.” On-screen prompts will confirm that the receiver has been programmed or if there are any issues.
3. Data will need to be sent separately for the Unit Info and CAN Configuration screens.

### *Receiving (Reading) the PGT Programming*

To read a program file from the PGT Transmitter:

1. Plug in the USB programming cable.
2. Click “Receive” and follow the on-screen prompts.
3. RCP will confirm reception and automatically display current programming in the PGT unit.

### *Reading the RCP Software Version*

1. Select “Help”.
2. Select “About”.
3. The RCP Software Version number will be displayed.

### *Resetting PGT Back to Factory Default Settings*

1. Select “Reset to Defaults” button.
2. A dialog box will pop up confirming that you want to proceed. Click the button “OK” to restore the factory default settings. On-screen prompts will confirm that the transmitter has been reset to defaults or if there are any issues.
3. Power cycle the PGT transmitter to implement the factory default values.

**NOTE:** *Resetting the system back to factory defaults only restores the factory settings for the CAN configuration settings. All other settings will not be altered.*

## 6.0 TRANSMITTER CHANNEL CONFIGURATION SETTINGS

The RF channel can be set via the setup mode or the optional RCP software on systems equipped with the optional graphic user interface, or by using the dip switch block on systems not equipped with the optional graphic user interface. The following Sections 6.2 and 6.3 show the channels and protocols available for each transmitter radio frequency option.

*NOTE: When using the optional RCP software on transmitters NOT equipped with the optional graphic user interface, the channel settings will read from the dip switch positions and not from memory when the channel from memory override function is not enabled. The RF channel set by the optional RCP software will not be used unless the memory override dip switch is set to ON. When the RF channel from memory override is NOT enabled, the dip switch positions set the RF channel used by the Transmitter.*

## 6.1 FCC STATEMENTS

### Compliance Statement (Part 15.19)

This device complies with Part 15 of FCC rules.

Operation is subject to the following two conditions:

1. This device may not cause harmful interference, and
2. This device must accept any interference received, including interference that may cause undesired operation.

### Warning (Part 15.21)

Changes or modifications not expressly approved by the party responsible for compliance should void the user's authority to operate the equipment.

This portable transmitter with its antenna complies with FCC's RF exposure limits for general population/uncontrolled exposure.

## 6.2 CHANNEL AND FREQUENCY DESIGNATIONS BY COUNT

### 433 MHz: TMS and TDMA

Channel Count	Channel Designator	Actual Frequency
01)	01	433.000 MHz
02)	02	433.050 MHz
03)	03	433.100 MHz
04)	04	433.150 MHz
05)	05	433.200 MHz
06)	06	433.250 MHz
07)	07	433.300 MHz
08)	08	433.350 MHz
09)	09	433.400 MHz
10)	10	433.450 MHz
11)	11	433.500 MHz
12)	12	433.550 MHz
13)	13	433.600 MHz
14)	14	433.650 MHz
15)	15	433.700 MHz
16)	16	433.750 MHz
17)	17	433.800 MHz
18)	18	433.850 MHz
19)	19	433.900 MHz
20)	20	433.950 MHz
21)	21	434.000 MHz
22)	22	434.050 MHz
23)	23	434.100 MHz
24)	24	434.150 MHz
25)	25	434.200 MHz
26)	26	434.250 MHz
27)	27	434.300 MHz
28)	28	434.350 MHz
29)	29	434.400 MHz
30)	30	434.450 MHz
31)	31	434.500 MHz
32)	32	434.550 MHz

**Table 1.A**

### 900 MHz: TMS and TDMA

Channel Count	Channel Designator	Actual Frequency
01)	1	903.30 MHz
02)	2	906.30 MHz
03)	3	907.80 MHz
04)	4	909.30 MHz
05)	5	912.30 MHz
06)	6	915.30 MHz
07)	7	919.80 MHz
08)	8	921.30 MHz
09)	A	902.30 MHz
10)	B	904.10 MHz
11)	C	904.30 MHz
12)	D	905.10 MHz
13)	E	905.50 MHz
14)	F	905.70 MHz
15)	G	906.60 MHz
16)	H	908.70 MHz
17)	I	908.90 MHz
18)	J	909.10 MHz
19)	K	910.10 MHz
20)	L	910.70 MHz
21)	M	911.00 MHz
22)	N	911.20 MHz
23)	O	912.00 MHz
24)	P	914.20 MHz
25)	Q	914.40 MHz
26)	R	914.60 MHz
27)	S	914.80 MHz
28)	T	915.80 MHz
29)	U	917.40 MHz
30)	V	923.20 MHz
31)	W	927.00 MHz
32)	X	927.30 MHz

**Table 1.B**



## 6.3 OPTIONAL FREQUENCIES AND CHANNELS

### 6.3.1 900 MHz: FHSS

Channel sets are designated between 1 and 32. The frequency range is between 902-928 MHz. The frequency hopping protocol does not use one particular frequency to transmit a message. Messages are transmitted over multiple frequencies in a predefined sequence or channel set. In doing so, this protocol is able to compensate for interference that may be present on a single frequency by sending the message across multiple frequencies.

### 6.3.2 2.4 GHz: FHSS

Channel sets are designated between 1 and 32. The frequency range is between 2402-2478 MHz. The frequency hopping protocol does not use one particular frequency to transmit a message. Messages are transmitted over multiple frequencies in a predefined sequence or channel set. In doing so, this protocol is able to compensate for interference that may be present on a single frequency by sending the message across multiple frequencies.

### 6.3.3 433 MHz Telemotive Legacy Channel Set: TMS and TDMA

Channel Count	Channel Designator	Actual Frequency
01)	AK01	439.8 MHz
02)	AK02	439.6 MHz
03)	AK03	439.4 MHz
04)	AK04	439.2 MHz
05)	AK05	439.0 MHz
06)	AK06	438.8 MHz
07)	AK07	438.6 MHz
08)	AK08	438.4 MHz
09)	AK09	438.2 MHz
10)	AK10	438.0 MHz
11)	AK11	437.8 MHz
12)	AK12	437.6 MHz
13)	AK13	437.4 MHz
14)	AK14	437.2 MHz
15)	AK15	437.0 MHz
16)	AK16	436.8 MHz
17)	AK17	436.6 MHz
18)	AK18	436.4 MHz
19)	AK19	436.2 MHz
20)	AK20	436.0 MHz
21)	AKA00	433.125 MHz
22)	AKA01	433.325 MHz
23)	AKA02	433.525 MHz
24)	AKA03	433.725 MHz
25)	AKA04	433.925 MHz
26)	AKA05	434.125 MHz
27)	AKA06	434.325 MHz
28)	AKA07	434.525 MHz
29)	AKA08	434.725 MHz
30)	AK38	432.4 MHz
31)	AK50	430.0 MHz

Table 2

## 7.0 OPTIONAL CAN BUS TETHER FEATURE

The PGT transmitter can be ordered with an optional CAN bus tether feature. This feature allows for the operation of the transmitter as a wired transmitter with no wireless radio transmission. If the PGT transmitter was ordered with the CAN bus tether feature, this section applies to features and operation of the transmitter in tether mode.

### 7.1 INSTALLATION OF TETHER CABLE

The tether cable is attached to the CAN connector on the transmitter by lining up the alignment groove and inserting the plug into the CAN connector receptacle. Twist the locking ring on the CAN plug clockwise to tighten it down and prevent accidental disengagement.

### 7.2 OPERATION OF TRANSMITTER IN TETHER MODE

With the tether cable attached, turn on the transmitter following the start up sequence as outlined in Section 3.2.

During the start up sequence the transmitter will automatically recognize that the tether cable is attached and communicating and switch into tether mode. Tether mode turns off the wireless transmitter and sends all command signals through the tether cable.

If the transmitter has the optional graphic user interface screen installed, visual verification of the transmitter being in tether mode can be observed on the screen.

*NOTE: The transmitter must go through the start up initialization sequence with the tether cable attached to activate tether mode.*

All controls on the transmitter will function the same regardless of whether the transmitter is in tether mode or wireless mode.

*NOTE: While the tether cable provides power to the transmitter when connected, it will not recharge batteries in the transmitter. To recharge batteries, you must only use the Magnetek Enrange approved chargers for the appropriate battery pack.*

### 7.3 RETURNING TRANSMITTER TO WIRELESS MODE

To return the transmitter to wireless mode, power down the unit and disconnect the tether cable. Following the start up sequence from Section 3.2, restart the transmitter. The transmitter will automatically sense that it is no longer connected to the tether cable and start the unit in its normal wireless mode.

#### 7.4 CAN CONNECTOR RECEPTACLE PIN-OUT DETAILS

The CAN connector receptacle located on the transmitter has specific pin assignments. It is very critical that these pin assignments are matched in the CAN cable assembly.

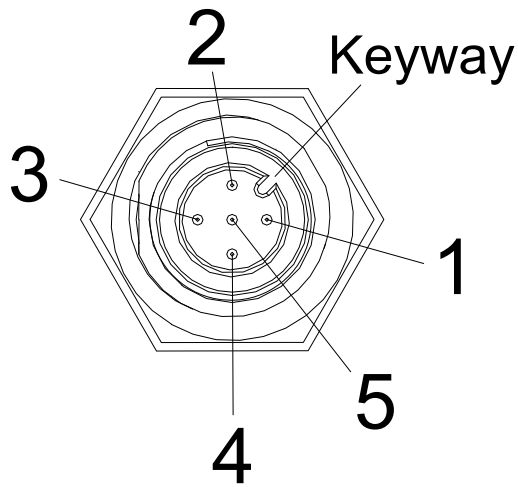

CONNECTOR PINOUT (MALE PIN CONNECTOR)	
5-PIN CONNECTOR	FUNCTION
PIN 1	SHIELD
PIN 2	+12/24VDC
PIN 3	-12/-24VDC (common)
PIN 4	CAN-H
PIN 5	CAN-L

Figure 14: CAN Connector Pin Out details

## 8.0 GENERAL TROUBLESHOOTING

Problems	Possible Reasons	Suggestions
<b>Transmitter will not turn on</b>	Batteries are dead or installed backwards; battery holder is damaged.	Replace the batteries and confirm they are installed according to the polarity marking in the battery pack. Inspect all battery pack contacts for damage. When installing the battery pack into the PGT, confirm it is installed with the label facing out.
	Transmitter is failing switch scan	Be sure all switches and motions are in the off position on startup. See Section 3.2 for more info.
	Transmitter Machine Stop Switch is down or pressed	Be sure the Machine Stop switch is pulled up.
<b>Transmitter will not respond with the receiver</b>	Incorrect system RF channel	Make sure the transmitter and receiver unit are both set to the same RF channel. See Section 4.2.2.
	Incorrect system access code	Make sure the transmitter and receiver both have the same access code. See Section 4.2.1.
	System out of range	Make sure that the startup procedure is initiated within 300 feet from the receiver location. If equipped with the Signal Strength Indicator, make sure the level is greater than 0%.
	The antenna on the receiver is missing, damaged, or improperly installed.	Inspect the antenna on the receiver for damage and try to locate the antenna in a location that is visible when operating the equipment at all times.

## 8.1 TROUBLESHOOTING OPTIONAL TETHER OPERATION

Problems	Possible Reasons	Suggestions
<b>Transmitter will not turn on</b>	Connecting tether cable is not installed, installed improperly, or is damaged.	Inspect the tether cable and confirm that it is installed and secured correctly. Inspect all connector, connector contacts and cable jacket for damage.
	Transmitter is failing switch scan	Be sure all switches and motions are in the off position on startup. See Section 3.2 for more info.
	Transmitter machine stop switch is down or pressed	Be sure the Machine Stop switch is pulled up.
<b>Transmitter will not respond with the receiver in tether mode</b>	System not in tether mode	Make sure that the startup procedure is initiated with the tether cable attached. Ensure that all tether cable connections are secure prior to startup.
	The tether cable or connectors are damaged	Inspect the tether cable and connectors for damage.
	CAN settings are incorrect	Verify CAN settings match project specific CAN bus document
<b>Transmitter will not respond with the receiver in wireless mode</b>	System not in wireless mode	Make sure that the startup procedure is initiated with the tether cable detached. Ensure that the startup procedure is initiated within 300 feet from the receiver location.

## 8.2 ASSEMBLY AND REPLACEMENT PARTS

If your transmitter ever needs repair, we always recommend that you have Magnetek perform the repair. If you need to refer to a parts list, refer to your transmitter's drawing that was included in the shipment of your transmitter. Please contact Magnetek's service department at 1.866.MAG.SERV for information regarding parts and service.



### Transmitter Specification

**Temperature Range:**

- -40°F to 185°F (-40°C to 85°C)

**Environmental Protection:**

- IP66 and NEMA 4 Transmitter

**Operation Range:**

- Non-Licensed Part 15 Up to 300 feet (91.44 m)
- Non-Licensed FHSS Up to 3000 feet (914.4 m)

**Frequency Range:**

- Non-Licensed Part 15 430-439.8 MHz / 902-928 MHz
- Non-Licensed FHSS 902-928 MHz / 2.4-2.5 GHz
- Government Band 405-430 MHz

**Output Power:**

- Non-Licensed Part 15 Less than 1mW
- Non-Licensed FHSS 10 mW, 100 mW, 200 mW
- Government Band 1mW

**RF Channels**

- Non-Licensed Part 15 32 channels
- Non-Licensed FHSS 32 channels
- Government Band Up to 1000 frequencies

**Antenna:**

- Internal
- External Optional

**RF Type:**

- TMS (Time Multiplexed Signaling)
- FHSS (Frequency Hopping Spread Spectrum)
- Microprocessor Controlled PLL Synthesizer
- Transceiver

**Response Time:**

- Approximately 50 ms

**Test & Certifications:**

- FCC Approved Part 15, Part 90
- IEC 68-2-34 Random Vibration
- IEC 68-2-27 Shock Testing
- IEC 68-2-31 Drop & Topple
- SAE 1211 Dust Testing

**Graphic Display:**

- Backlit display
- 2" x 1.22" (51 x 31 mm)
- Multilingual with standard ACSII characters

**Weight:**

- Approximately 1.5 lbs (1.13 kg)

**Dimensions:**

- Approximately 6.5" x 4.9" x 4.6" (165 x 125 x 117 mm)

### Transmitter Component Specifications

A total of 8 inputs are available for analog components.

**Joystick:**

- Dual Axis stepless/proportional, up to 4 per transmitter
- Optional stepless/proportional third Axis, 2 per transmitter (IP65)
- Square Gate standard, Plus Gate optional

**Proportional Trigger Switch:**

- Hall Effect, transmitter enable

**Potentiometers:**

- Single turn

A total of 15 Toggle Switches or 30 inputs are available for digital components.

**Toggle Switch:**

- 2 position momentary
- 2 position maintained
- 3 position momentary
- 3 position maintained
- 3 position maintained/momentary

**Push Button:**

- Momentary
- Red, Green, Blue, Black, Yellow

**E-STOP:**

- Military Grade Push/Pull

**LED:**

- Red, Yellow, Green, up to 4 per transmitter

**Rotary Switch:**

- Up to 12 positions per switch

**Key Switch:**

- 3 position maintained/momentary
- 2 position maintained

**USB:**

- Programming Port, Optional

**Infrared Port:**

- Programming Port, Optional

**Labeling:**

- Custom labels per application
- Multilingual
- Multi-Color

Note: Other components (joysticks, switches, potentiometers, etc.) may be available upon request. Consult the factory for compatibility.

P.O. Box 13615  
Milwaukee, WI 53213  
Toll-Free Phone 800.288.8178

N49 W13650 Campbell Drive  
Menomonee Falls, WI 53051  
Phone 262.783.3500

Enrange Facility  
#5 Four Coins Drive  
Canonsburg, PA 15317

Canada Facility  
2610 Dunwin Drive  
Mississauga, Ontario

www.magnetekmh.com



**MAGNETEK**  
E N R A N G E

# PulseStar™ PGT

Technical Specifications

## Battery and Charger

### Battery Type:

- **Rechargeable:** 3.6 V NiMH, 3Cell Pack, 2100 mAh
- **Disposable:** Three AA Alkaline Pack, 2300 mAh

### Service Life:

- **Rechargeable:** 500 cycles

### Battery Contacts:

- Gold Plated

### Battery Chargers:

- Maximum 3 chargers per power supply

**\*\* Note: Charger will only work with rechargeable pack \*\***

### Battery Charge Time:

- **Fast Charge:** Approx. 2-3 hours

### Charger Power:

- 120 Vac 60 Hz, 12/24 Vdc

## TYPICAL APPLICATION LAYOUTS

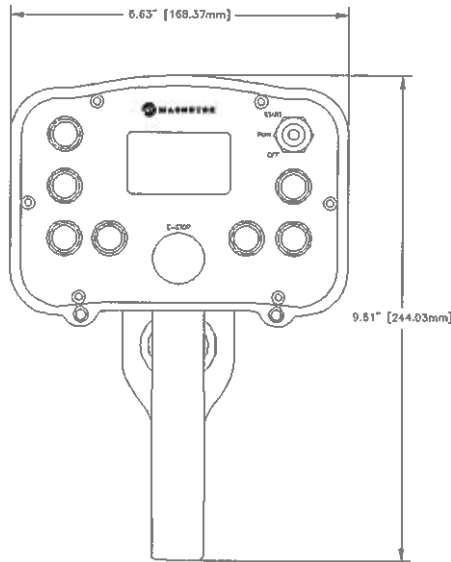

**PGT Configuration with Pushbuttons**

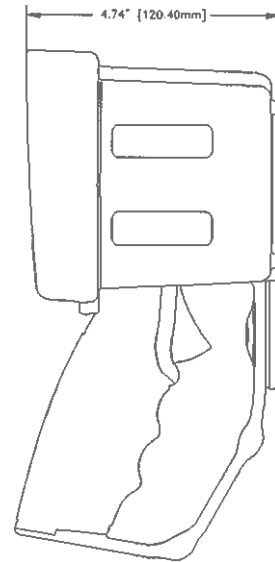

**PGT Side View**

P.O. Box 13615  
Milwaukee, WI 53213  
Toll-Free Phone 800.288.8178  
Toll-Free Fax 800.288.2503

N49 W13650 Campbell Drive  
Menomonee Falls, WI 53051  
Phone 262.783.3500  
Fax 262.783.2510

Enrange Facility  
#5 Four Coins Drive  
Canonsburg, PA 15317  
Phone 717.261.2510

Canada Facility  
2610 Dunwin Drive  
Mississauga, Ontario  
L4X 1L7

[www.magnetekmh.com](http://www.magnetekmh.com)





**MAGNETEK**  
E N R A N G E

# PulseStar™ PGT

Technical Specifications

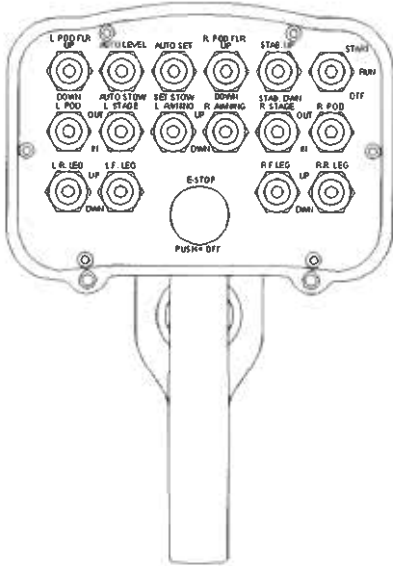

**PGT with 15 Toggles**

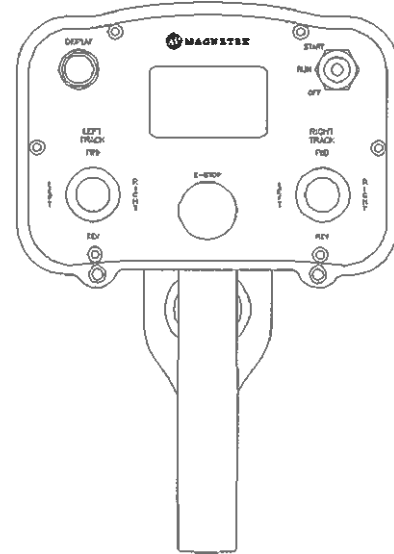

**PGT with 2 Joysticks**

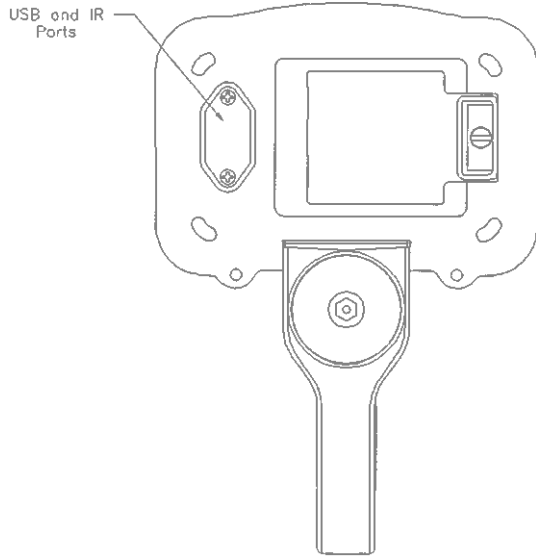

**IR and USB Port Location**

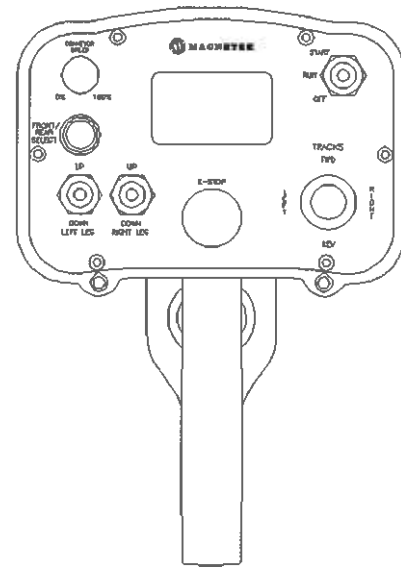

**PGT with Assorted Components**

P.O. Box 13615  
Milwaukee, WI 53213  
Toll-Free Phone 800.288.8178

N49 W13650 Campbell Drive  
Menomonee Falls, WI 53051  
Phone 262.783.3500

Enrange Facility  
#5 Four Coins Drive  
Cannonburg, PA 15317

Canada Facility  
2610 Dunwin Drive  
Mississauga, Ontario

[www.magnetekmh.com](http://www.magnetekmh.com)

