



Flex Pro Tethered Controller

Remote Control Equipment Instruction Manual



MAGNETEK
E N R A N G E

198-00132-R1

July 2011

© Copyright 2011 Magnetek Material Handling

Service Information

Your New Remote Control System

Thank you for your purchase of Magnetek's Enrange™ Flex Pro Tethered Controller. Without a doubt, our Flex Pro systems are the ultimate solution for providing precise, undeterred, and safe control of your material.

If your product ever needs modification or service, please contact one of our representatives at the following locations:

U.S. Service Information:

For questions regarding service or technical information, contact:

Magnetek, Inc.
#5 Four Coins Drive
Canonsburg, PA 15317

Telephone: 1.866.MAG.SERV (1.866.624.7378)

Website: www.magnetekmobilehydraulic.com

E-mail: info@magnetekmh.com

Fax Numbers:

Main: 1.800.298.3503

Sales: 1.262.783.3510

Service: 1.262.783.3508

Canada Service Information:

4090B Sladeview Crescent

Mississauga, Ontario

L5L 5Y5 Canada

Telephone: 1.800.792.7253

Fax: 1.905.828.5707

1.416.424.7617 (24/7 Service pager)

Table of Contents

	Page
1. Introduction	3
2. Remote Controlled Safety	4
3. General Controller Information	
A. External Illustration (Pro 12 Configuration)	8
B. Internal Illustration (Pro 12 Configuration)	9
C. Types of Buttons	10
D. Adjustable Speed Control	10
4. Dip-Switch Settings	
A. Inactivity Time-Out Timer	11
5. Setup	
A. Installation of Tethered Controller Cable	12
B. CAN Connector Pinout	12
C. CAN Protocols	13
6. Operating Procedure	
A. General Operating Procedure	15
B. Status Light Indicators & Warnings	16
C. Push Button Error Table	17
D. Trouble Shooting Tips	17

PRODUCT MANUAL SAFETY INFORMATION

Magnetek, Inc. (Magnetek) offers a broad range of radio remote control products, control products and adjustable frequency drives, and industrial braking systems for material handling applications. This manual has been prepared by Magnetek to provide information and recommendations for the installation, use, operation and service of Magnetek's material handling products and systems (Magnetek Products). Anyone who uses, operates, maintains, services, installs or owns Magnetek Products should know, understand and follow the instructions and safety recommendations in this manual for Magnetek Products.

The recommendations in this manual do not take precedence over any of the following requirements relating to cranes, hoists lifting devices or other material handling equipment which use or include Magnetek Products:

- Instructions, manuals, and safety warnings of the manufacturers of the equipment where the radio system is used,
- Plant safety rules and procedures of the employers and the owners of facilities where the Magnetek Products are being used,
- Regulations issued by the Occupational Health and Safety Administration (OSHA),
- Applicable local, state or federal codes, ordinances, standards and requirements, or
- Safety standards and practices for the industries in which Magnetek Products are used.

This manual does not include or address the specific instructions and safety warnings of these manufacturers or any of the other requirements listed above. It is the responsibility of the owners, users and operators of the Magnetek Products to know, understand and follow all of these requirements. It is the responsibility of the employer to make its employees aware of all of the above listed requirements and to make certain that all operators are properly trained. **No one should use Magnetek Products prior to becoming familiar with and being trained in these requirements and the instructions and safety recommendations in this manual.**

WARRANTY INFORMATION

FOR INFORMATION ON MAGNETEK'S PRODUCT WARRANTIES BY PRODUCT TYPE, PLEASE VISIT WWW.MAGNETEKMH.COM.

Flex Pro Tethered Controller
Instruction Manual
July 2011
2 of 17

1. Introduction

The Flex remote control systems are designed for control of industrial equipment and mobile machinery such as overhead traveling cranes, construction equipment, forestry equipment, mining equipment, rail equipment, drilling & trenching equipment, agriculture equipment, electric hoists, winches, monorails, conveyor belts, mining equipment and other material handling equipment where hardwired remote control is preferred.

List of notable features include:

- * **Over one million unique ID codes (20bit)** – Each and every Flex system has its own unique ID code; no repeats.
- * **Advanced controls** – The Flex system utilizes advanced microprocessor controls with 16-bit CRC which provides ultra fast, safe, precise, and error-free encoding and decoding.
- * **Unique I-CHIP design** – The I-CHIP functions in a way that is very similar to SIM cards used on mobile phones, with the ability to transfer system information and settings from one transmitter to another without the hassle of resetting the spares.
- * **Reliable push buttons** – The in-house designed push buttons are rated for more than one million press cycles.
- * **Ultra-durable nylon and fiberglass composite enclosures** – Highly resistant to breakage and deformation even in the most abusive environments.
- * **Full compliance** – All systems are fully compliant with the European Directives (Safety, EMC, R&TTE, and Machinery) and Industry Canada Specifications (IC).

Flex Pro Tethered Controller
Instruction Manual
July 2011
3 of 17

2. Remote Controlled Safety

WARNINGS and CAUTIONS

Throughout this document WARNING and CAUTION statements have been deliberately placed to highlight items critical to the protection of personnel and equipment.

WARNING – A warning highlights an essential operating or maintenance procedure, practice, etc. which if not strictly observed, could result in injury or death of personnel, or long term physical hazards. Warnings are highlighted as shown below:



CAUTION – A caution highlights an essential operating or maintenance procedure, practice, etc. which if not strictly observed, could result in damage to, or destruction of equipment, or loss of functional effectiveness. Cautions are highlighted as shown below:



WARNINGS and CAUTIONS SHOULD NEVER BE DISREGARDED.

The safety rules in this section are not intended to replace any rules or regulations of any applicable local, state, or federal governing organizations. Always follow your local lockout and tagout procedure when maintaining any radio equipment. The following information is intended to be used in conjunction with other rules or regulations already in existence. It is important to read all of the safety information contained in this section before installing or operating the Remote Control System.

Flex Pro Tethered Controller
Instruction Manual
July 2011
4 of 17

2.1: CRITICAL INSTALLATION CONSIDERATIONS



WARNING

PRIOR TO INSTALLATION AND OPERATION OF THIS EQUIPMENT, READ AND DEVELOP AN UNDERSTANDING OF THE CONTENTS OF THIS MANUAL AND THE OPERATION MANUAL OF THE EQUIPMENT OR DEVICE TO WHICH THIS EQUIPMENT WILL BE INTERFACED. FAILURE TO FOLLOW THIS WARNING COULD RESULT IN SERIOUS INJURY OR DEATH AND DAMAGE TO EQUIPMENT.

ALL EQUIPMENT MUST HAVE A MAINLINE CONTACTOR INSTALLED AND ALL TRACKED CRANES, HOISTS, LIFTING DEVICES AND SIMILAR EQUIPMENT MUST HAVE A BRAKE INSTALLED. FAILURE TO FOLLOW THIS WARNING COULD RESULT IN SERIOUS INJURY OR DEATH AND DAMAGE TO EQUIPMENT.

AN AUDIBLE AND/OR VISUAL WARNING MEANS MUST BE PROVIDED ON ALL REMOTE CONTROLLED EQUIPMENT AS REQUIRED BY CODE, REGULATION, OR INDUSTRY STANDARD. THESE AUDIBLE AND/OR VISUAL WARNING DEVICES MUST MEET ALL GOVERNMENTAL REQUIREMENTS. FAILURE TO FOLLOW THIS WARNING COULD RESULT IN SERIOUS INJURY OR DEATH AND DAMAGE TO EQUIPMENT.

FOLLOW YOUR LOCAL LOCKOUT TAGOUT PROCEDURE BEFORE MAINTAINING ANY REMOTE CONTROLLED EQUIPMENT. ALWAYS REMOVE ALL ELECTRICAL POWER FROM THE CRANE, HOIST, LIFTING DEVICE OR SIMILAR EQUIPMENT BEFORE ATTEMPTING ANY INSTALLATION PROCEDURES. DE-ENERGIZE AND TAGOUT ALL SOURCES OF ELECTRICAL POWER BEFORE TOUCH-TESTING ANY EQUIPMENT. FAILURE TO FOLLOW THIS WARNING COULD RESULT IN SERIOUS INJURY OR DEATH AND DAMAGE TO EQUIPMENT.

THE DIRECT OUTPUTS OF THIS PRODUCT ARE NOT DESIGNED TO INTERFACE DIRECTLY TO TWO STATE SAFETY CRITICAL MAINTAINED FUNCTIONS, I.E., MAGNETS, VACUUM LIFTS, PUMPS, EMERGENCY EQUIPMENT, ETC. A MECHANICALLY LOCKING INTERMEDIATE RELAY SYSTEM WITH SEPARATE POWER CONSIDERATIONS MUST BE PROVIDED. FAILURE TO FOLLOW THIS WARNING COULD RESULT IN SERIOUS INJURY OR DEATH OR DAMAGE TO EQUIPMENT.

2.2: GENERAL

Remote controlled material handling equipment operates in several directions. Cranes, hoists, lifting devices and other material handling equipment can be large, and operate at high speeds. Quite frequently, the equipment is operated in areas where people are working in close proximity to the material handling equipment. **The operator must exercise extreme caution at all times.** Workers must constantly be alert to avoid accidents. The following recommendations have been included to indicate how careful and thoughtful actions may prevent injuries, damage to equipment, or even save a life.

2.3: PERSONS AUTHORIZED TO OPERATE REMOTE CONTROLLED CRANES

Only properly trained persons designated by management should be permitted to operate remote controlled equipment.

Remote controlled cranes, hoists, lifting devices and other material handling equipment should not be operated by any person who cannot read or understand signs, notices and operating instructions that pertain to the equipment.

Remote controlled equipment should not be operated by any person with insufficient eyesight or hearing or by any person who may be suffering from a disorder or illness, is taking any medication that may cause loss of equipment control, or is under the influence of alcohol or drugs.

Flex Pro Tethered Controller
Instruction Manual
July 2011
5 of 17

2.4: SAFETY INFORMATION AND RECOMMENDED TRAINING FOR REMOTE CONTROLLED EQUIPMENT OPERATORS

Anyone being trained to operate remote controlled equipment should possess as a minimum the following knowledge and skills before using the remote controlled equipment.

The operator should

:

- have knowledge of hazards pertaining to equipment operation
- have knowledge of safety rules for remote controlled equipment
- have the ability to judge distance of moving objects
- know how to properly test prior to operation
- be trained in the safe operation of the controller as it pertains to the crane, hoist, lifting device or other material handling equipment being operated
- have knowledge of the use of equipment warning lights and alarms
- have knowledge of the proper storage space for a controller when not in use
- be trained in transferring a controller to another person
- be trained how and when to report unsafe or unusual operating conditions
- test the controller emergency stop and all warning devices prior to operation; testing should be done on each shift, without a load
- be thoroughly trained and knowledgeable in proper and safe operation of the crane, hoist, lifting device, or other material handling equipment that utilizes the remote control
- know how to keep the operator and other people clear of lifted loads and to avoid “pinch” points
- continuously watch and monitor status of lifted loads
- know and follow cable and hook inspection procedures
- know and follow the local lockout and tagout procedures when servicing remote controlled equipment
- know and follow all applicable operating and maintenance manuals, safety procedures, regulatory requirements, and industry standards and codes

The operator shall not

_____:

- lift or move more than the rated load
- operate the material handling equipment if the direction of travel or function engaged does not agree with what is indicated on the controller
- use the crane, hoist or lifting device to lift, support or transport people
- lift or carry any loads over people
- operate the crane, hoist or lifting device unless all persons, including the operator, are and remain clear of the supported load and any potential pinch points
- operate a crane, hoist or lifting device when the device is not centered over the load
- operate a crane, hoist or lifting device if the chain or wire rope is not seated properly in the sprockets, drum or sheave
- operate any damaged or malfunctioning crane, hoist, lifting device or other material handling equipment

- change any settings or controls without authorization and proper training
- remove or obscure any warning or safety labels or tags
- leave any load unattended while lifted
- leave power on the remote controlled equipment when the equipment is not in operation
- operate any material handling equipment using a damaged controller because the unit may be unsafe
- operate manual motions with other than manual power



WARNING

THE OPERATOR SHOULD NOT ATTEMPT TO REPAIR ANY TETHERED CONTROLLER. IF ANY PRODUCT PERFORMANCE OR SAFETY CONCERNS ARE OBSERVED, THE EQUIPMENT SHOULD IMMEDIATELY BE TAKEN OUT OF SERVICE AND BE REPORTED TO THE SUPERVISOR. DAMAGED AND INOPERABLE TETHERED CONTROLLER EQUIPMENT SHOULD BE RETURNED TO MAGNETEK FOR EVALUATION AND REPAIR. FAILURE TO FOLLOW THIS WARNING COULD RESULT IN SERIOUS INJURY OR DEATH AND DAMAGE TO EQUIPMENT.

2.5: CONTROLLER UNIT

Controller switches should never be mechanically blocked ON or OFF. When not in use, the operator should turn the controller OFF. A secure storage space should be provided for the controller unit, and the controller unit should always be placed there when not in use. This precaution will help prevent unauthorized people from operating the material handling equipment.

Spare controllers should be stored in a secure storage space and only removed from the storage space after the current controller in use has been turned OFF, taken out of the service area and secured.

2.6: PRE-OPERATION TEST

At the start of each work shift, or when a new operator takes control of the crane, operators should do, as a minimum, the following steps before making lifts with any crane or hoist:

Test all warning devices.

Test all direction and speed controls.

Test the controller emergency stop.

2.7: SPECIFIC SYSTEM WARNINGS

Below are some specific operating safety tips that should be strictly followed when operating a Flex Pro system:

1. Check the Status LED on the controller for any signs of irregularities (refer to page 16).

Flex Pro Tethered Controller
Instruction Manual
July 2011
7 of 17

3. General Controller Information

A. External Illustration (Pro 12 Configuration)

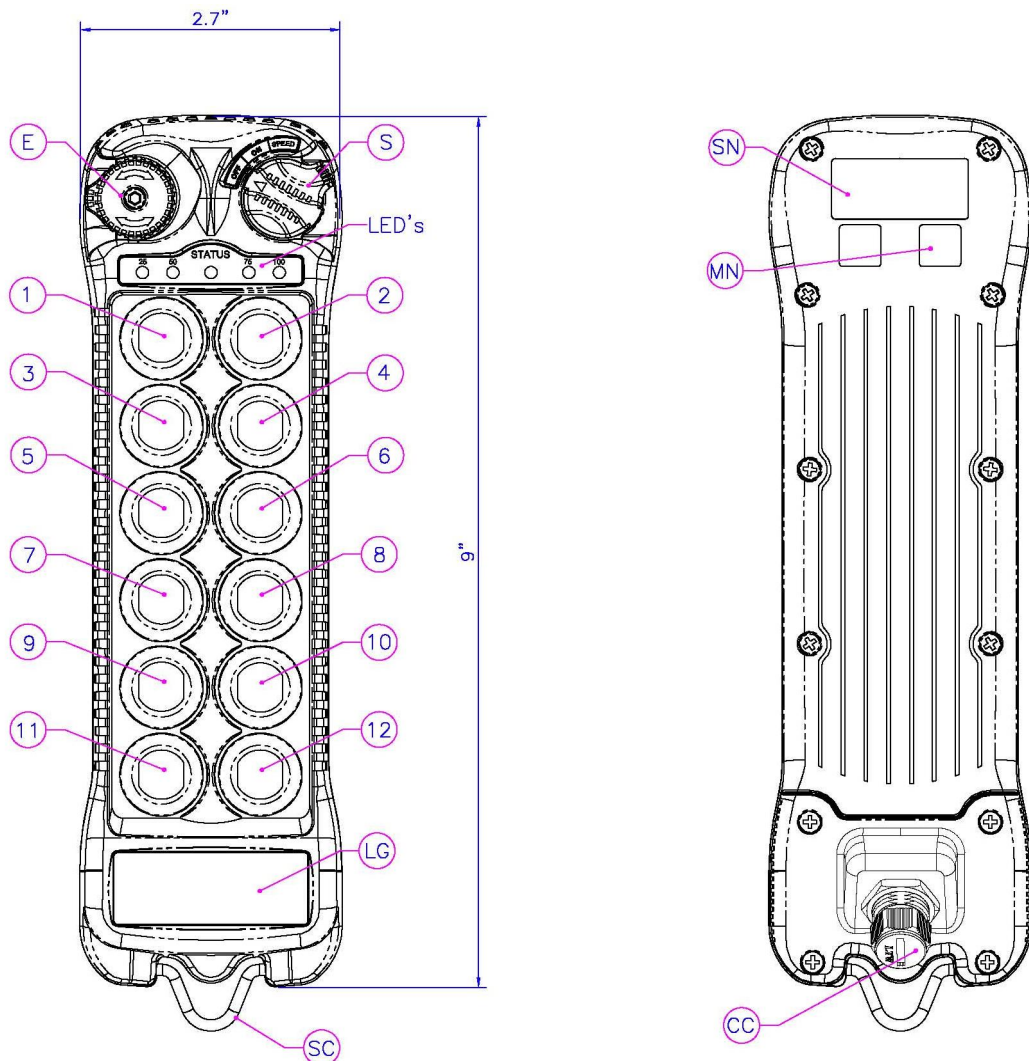

- | | | | | | |
|----|----------------------------|-----|-----------------|-----|--------------------|
| E | SC | 7. | Push Button #7 | SN. | System Information |
| S. | Removable Power Key Switch | 8. | Push Button #8 | CC. | CAN Connector |
| 1. | Push Button #1 | 9. | Push Button #9 | MN. | Crane Number |
| 2. | Push Button #2 | 10. | Push Button #10 | | |
| 3. | Push Button #3 | 11. | Push Button #11 | | |
| 4. | Push Button #4 | 12. | Push Button #12 | | |
| 5. | Push Button #5 | | | | |

NOTE: Push Buttons #9-#12 are not present on the Flex Pro 8 Module

B. Internal Illustration (Pro 12 Configuration)

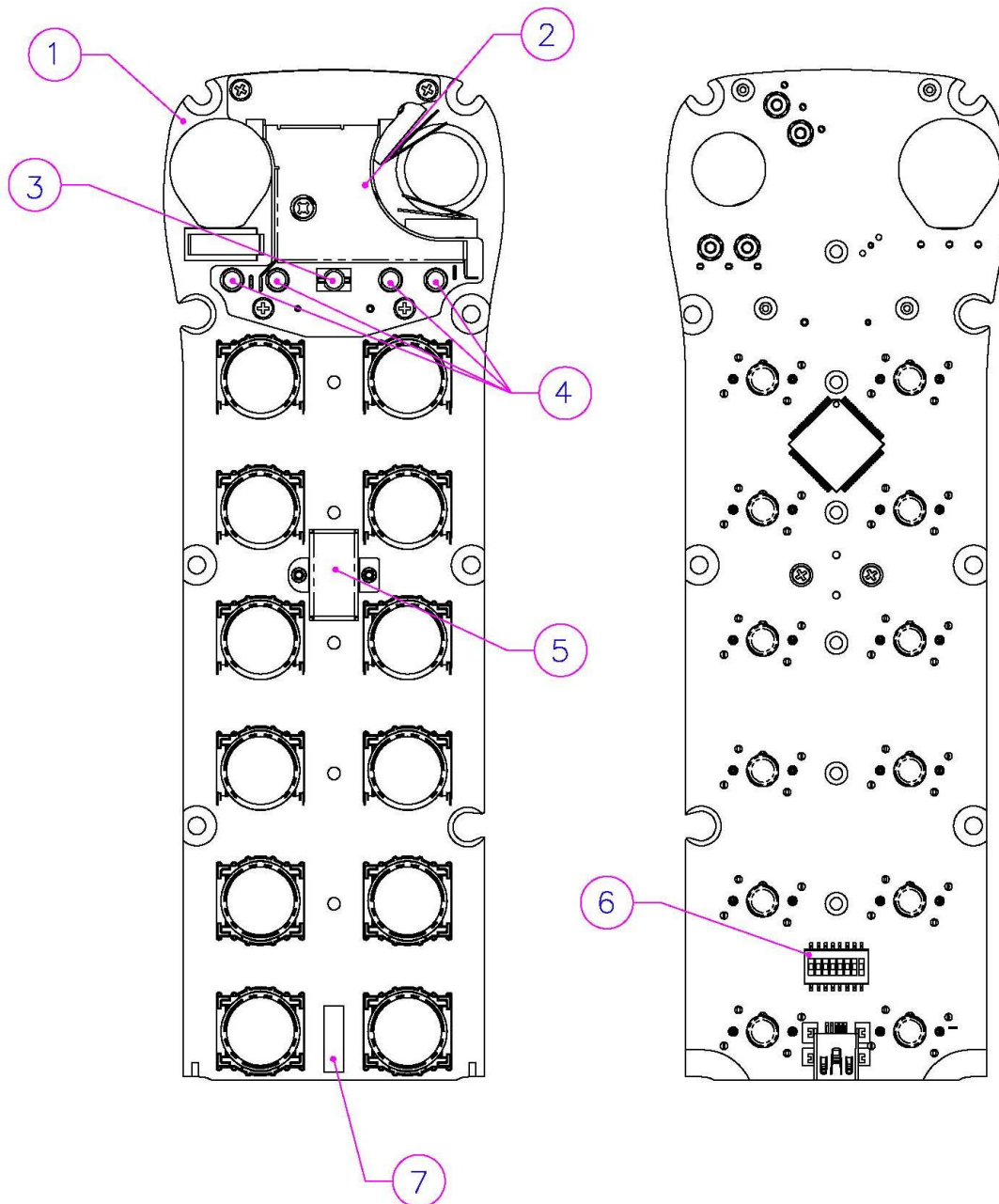

- 3. Status LED Display
- 4. Function LED Displays

- 7. CAN Connector

NOTE: Flex Pro 8 Module will differ slightly

Flex Pro Tethered Controller
 Instruction Manual
 July 2011
 9 of 17

C. Types of Buttons

The buttons used on the Flex Pro tethered controller are fully proportional, stepless push buttons with an output that varies 0-100% (based on how far the button is depressed). It is possible to model the stepless buttons as an On/Off momentary switch, On/Off latched switch, 2 Speed button, or a 3 Speed button. This modeling is done on the receiver end of the system. Please consult the factory for more information.

D. Adjustable Speed Control

The proportional buttons normally operate on a scale from 0-100%, but can also be scaled down to operate linearly from 0-75%, 0-50%, or 0-25% over the full motion of the button. This gives the user more control over lower speeds. To adjust the speed control settings, press and hold the Start button, then press push button 1 or push button 2 to decrement/increment the range percentage. The red LEDs, which indicate the Speed Setting, will then change to reflect the current setting.

Start +	Speed control setting
PB1	Decrement Speed Control
PB2	Increment Speed Control



(Fig. 05)

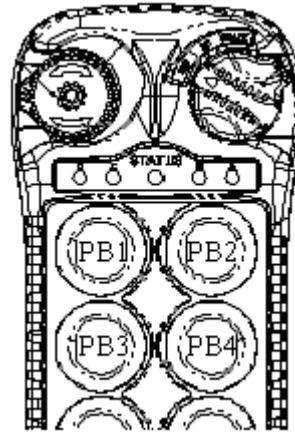

(Fig. 06)

4. Dip-Switch Settings

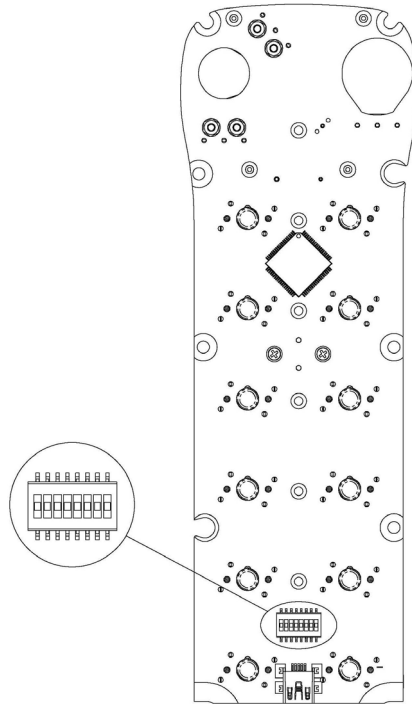

A. Inactivity

Bits 6 and 7 on the dip-switch allows the user to define a time after which, if no buttons on the controller are pressed, the Flex Pro tethered controller will send an OFF command to the equipment and power down. To restart, the user must turn the On/Off/Start switch to the Off position, then back to On again to resume operation.

Time Out	Dip-switch Setting
5 minutes	01
10 minutes	10
15 minutes	11
Never shut off	00

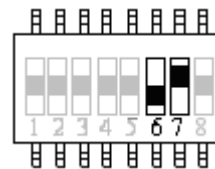

(Fig.08)

5. Setup

A. Installation of Tethered Controller Cable

The tethered controller cable is attached to the CAN connector on the controller by lining up the alignment groove and inserting the plug into the CAN connector receptacle. Twist the locking ring on the CAN plug clockwise to tighten it down and prevent accidental disengagement.

B. CAN Connector Pinout

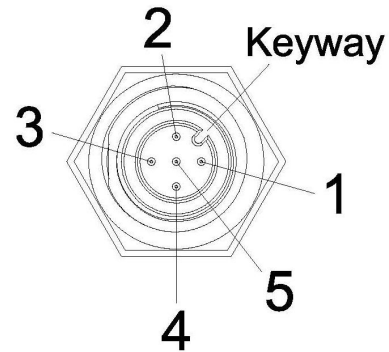
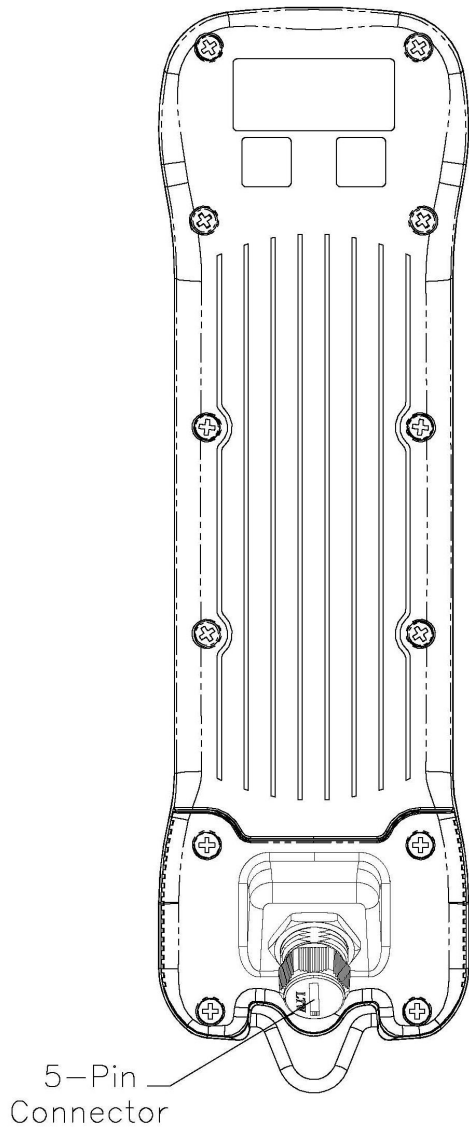

CONNECTOR PINOUT (MALE PIN CONNECTOR)	
5-PIN CONNECTOR	FUNCTION
PIN 1	CAN-H
PIN 2	GND
PIN 3	POWER
PIN 4	CAN-L
PIN 5	NOT USED

Flex Pro Tethered Controller
Instruction Manual
July 2011
12 of 17

C. CAN Protocols

The standard CAN messages that the Flex PRO tethered controller transmits are J1939. These messages are shown below. For custom messaging, consult the factory.

PGN 65325 (FF2D hex) through 65327 (FF2F hex)	Source Address 169 (A9 hex) Transmitter
Transmission Repetition Rate	50ms
Transmission Timeout	200ms
Data Length	8 bytes
Data Page	0
Priority	3

PGN	65325 (FF2D hex)							
Source Address	169 (A9 hex)							
1 st PGN / SA	Bit 7	Bit 6	Bit 5	Bit 4	Bit 3	Bit 2	Bit 1	Bit 0
Byte 1	7	6	5	4	3	2	1	0
Byte 2	5	4	3	2	1	0	9	8
Byte 3	3	2	1	0	9	8	7	6
Byte 4	1	0	9	8	7	6	5	4
Byte 5	9	8	7	6	5	4	3	2
Byte 6	7	6	5	4	3	2	1	0
Byte 7	5	4	3	2	1	0	9	8
Byte 8	1	0	1	0	9	8	7	6

Output 1	10 bit 0-to-1000
Output 2	10 bit 0-to-1000
Output 3	10 bit 0-to-1000
Output 4	10 bit 0-to-1000
Output 5	10 bit 0-to-1000
Output 6	10 bit 0-to-1000
E-Stop Command	00=off 01=on
Start/Horn	00=off 01=on

Flex Pro Tethered Controller
Instruction Manual
July 2011
13 of 17

PGN	65326 (FF2E hex)							
Source Address	169 (A9 hex)							
2nd PGN / SA	Bit 7	Bit 6	Bit 5	Bit 4	Bit 3	Bit 2	Bit 1	Bit 0
Byte 1	7	6	5	4	3	2	1	0
Byte 2	5	4	3	2	1	0	9	8
Byte 3	3	2	1	0	9	8	7	6
Byte 4	1	0	9	8	7	6	5	4
Byte 5	9	8	7	6	5	4	3	2
Byte 6	7	6	5	4	3	2	1	0
Byte 7	5	4	3	2	1	0	9	8
Byte 8	1	1	1	1	9	8	7	6

Output 7	10 bit 0-to-1000
Output 8	10 bit 0-to-1000
Output 9	10 bit 0-to-1000
Output 10	10 bit 0-to-1000
Output 11	10 bit 0-to-1000
Output 12	10 bit 0-to-1000

PGN	65327 (FF2F hex)								This is an optional PGN which will send any custom user alarms
Source Address	169 (A9 hex)								
3rd PGN / SA	Bit 7	Bit 6	Bit 5	Bit 4	Bit 3	Bit 2	Bit 1	Bit 0	
Byte 1	1	1	1	1	1	1	1	1	1
Byte 2	1	1	1	1	1	1	1	1	1
Byte 3	1	1	1	1	1	1	1	1	1
Byte 4	1	1	1	1	1	1	1	1	1
Byte 5	1	1	1	1	1	1	1	1	1
Byte 6	1	1	1	1	1	1	1	1	1
Byte 7	1	1	1	0	1	0	1	1	1
Byte 8	7	6	5	4	3	2	1	0	

User Alarm Enable Indication if User Alarm Input Field should be read or not

User Alarm Enable	00=off 01=on
User Alarm Condition	01=set 10=clear
User Alarm Input	8 bit 0-to-255

6. Operating Procedure

A. General Operating Procedure

1. Reset the red emergency stop button located on the top left hand side of the controller handset by rotating it either clockwise or counter clockwise. The red button will pop up.

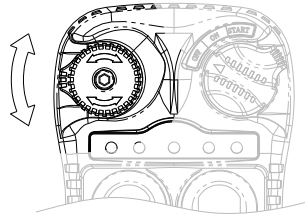

(Fig. 09)

2. Turn on the controller power by inserting the black-colored key into the power key slot located on the top right hand side of the controller handset and rotate it clockwise to the "On" position.

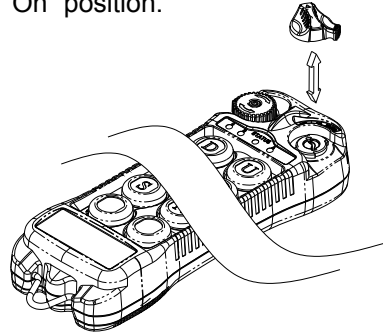

(Fig. 10)

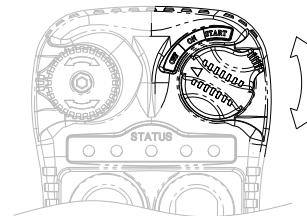

(Fig. 11)

3. After turning on the controller power, check the Status LED on the controller handset for any sign of system irregularities (refer to "Status Light Indicators & Warnings" on page 16). If the system is normal the Status LED will light up green for two (2) seconds, then slowly flash green.
4. If there are no signs of any system irregularities, then rotate the power key further clockwise to the "Start" position for up to 2 seconds. This will activate the E-Stop on the equipment. Thereafter, the same "Start" position will become an auxiliary function with momentary contact.

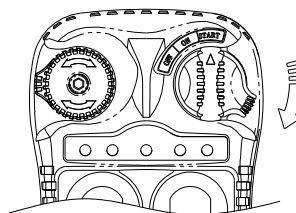

(Fig. 12)

Flex Pro Tethered Controller
Instruction Manual
July 2011
15 of 17

5. Now press any push button on the controller handset to operate the equipment. When a button is pressed, the Status LED will flash orange with a variable speed dependent on how far the button is pressed. The further a button is pressed, the faster the LED will flash. When no buttons are pressed, the Status LED will slowly blink green.
6. In case of an emergency, pressing down on the red emergency stop button will immediately disconnect the receiver E-Stop and turn off the unit. To reset the emergency stop button just rotate the red button either clockwise or counter-clockwise and then cycle power to the unit.
7. After a period of inactivity (push button not pressed) defined by the dip-switch, the receiver ESTOP will be disconnected and the unit must cycle power before turning on again.
8. Turn off the controller power by rotating the power key counter-clockwise to the "Off" position (Status LED becomes a solid red for 4 seconds). This will disconnect the controller power and the receiver E-Stop altogether. Turn it further counter-clockwise to release the key.

B. Status Light Indicators & Warnings

Type	Display Type	Indication
1	Slow green blink (Normal Operation)	Controller on and in standby.
2	Blinking orange	Button has been pressed and the unit is transmitting. The speed at which the orange LED blinks is directly related to how far down the button is pressed.
3	1 red blink followed by a 2-second pause	Voltage goes below 1.9V during operation - Check power supply immediately.
4	2 red blinks followed by a 2-second pause	A push button is active while turning on the controller. The button that is active will be designated by the (25, 50, 75, 100) LEDs. See Push Button Error Table below.
5	3 red blinks followed by a 2-second pause	I-CHIP error.
6	Constant green for up to 2 seconds	Controller power on with no faults detected (prior to initiating the START function).
7	Solid Red	Stop command initiated with equipment ESTOP deactivated.
8	Solid Red	Voltage goes below 1.9V at initial power on - controller power shuts off.



C. Push Button Error Table

25	50	75	100	Push Button
OFF	OFF	OFF	ON	1
OFF	OFF	ON	OFF	2
OFF	OFF	ON	ON	3
OFF	ON	OFF	OFF	4
OFF	ON	OFF	ON	5
OFF	ON	ON	OFF	6
OFF	ON	ON	ON	7
ON	OFF	OFF	OFF	8
ON	OFF	OFF	ON	9
ON	OFF	ON	OFF	10
ON	OFF	ON	ON	11
ON	ON	OFF	OFF	12

D. Trouble Shooting Tips

Problems	Possible Reasons	Suggestions
No response when controller push button is pressed (Improper startup & settings)	Controller low power	Check the CAN power supply.
	Emergency stop button activated prior to startup	Prior to turning on the controller power switch make sure that the red emergency stop button is elevated.
	Improper startup procedure	Redo the startup procedure by holding the power key at "START" position for up to 2.0 seconds and then release.
	Incorrect CAN ID	Make sure that the controller handset has the correct CAN ID.



Controller Specification

Temperature Range:

- -25°C to 75°C (-13°F to 167°F)

Environmental Protection:

- IP66 and NEMA 4 Controller

Connector Type:

- 5-pin keyed (see manual for pinout)

Response Time:

- Approximately 50 ms

Certifications:

- CE

Weight:

- 8 button – 7 oz
- 12 button – 10.5 oz

Dimensions:

- 8 button – (LxWxH) 7.2" x 3.0" x 1.3" (183 x 76 x 33 mm)
- 12 button – (LxWxH) 9.0" x 3.0" x 1.3" (227 x 76 x 33 mm)

Button Travel:

- 3/8 inch

Controller Component Specifications

**** Note: Each button can be configured as proportional, on/off momentary, or on/off latched. Other custom configurations are available. Please consult the factory for more information.**

Number of Proportional Functions:

- 8 button – 8, 0 to 100%, interlocked and non interlocked
- 12 button – 12, 0 to 100%, interlocked and non interlocked

Adjustable Speed Control Settings for Proportional Buttons:

- 4 settings – 25%, 50%, 75%, and 100%

On/Off/Start Switch

- 3 position, removable power key lock out

E-stop Switch

- Push to activate, twist to deactivate

I-CHIP

- Field programmable, 1 million reads/writes

LEDs

- 1 tri-color green/red/amber - Status LED Indicator
- 4 red – Adjustable Speed Mode Indicator (25, 50, 75, 100)

Power:

- 7.5-20 VDC

P.O. Box 13615
Milwaukee, WI 53213
Toll-Free Phone 800.288.8178
Toll-Free Fax 800.298.3503

N49 W13650 Campbell Drive
Menomonee Falls, WI 53051
Phone 262.783.3500
Fax 262.783.3510

Enrange Facility
#5 Four Coins Drive
Canonsburg, PA 15317
Phone 262.783.3500
Fax 262.783.3510

Canada Facility
2610 Dunwin Drive
Mississauga, Ontario
L5L 1J5 Canada
Toll Free Phone:
800.792.7253
Fax: 905.828.5707

www.magnetekmobilehydraulic.com

Brochure No. Flex Pro Tethered
Tech Specs

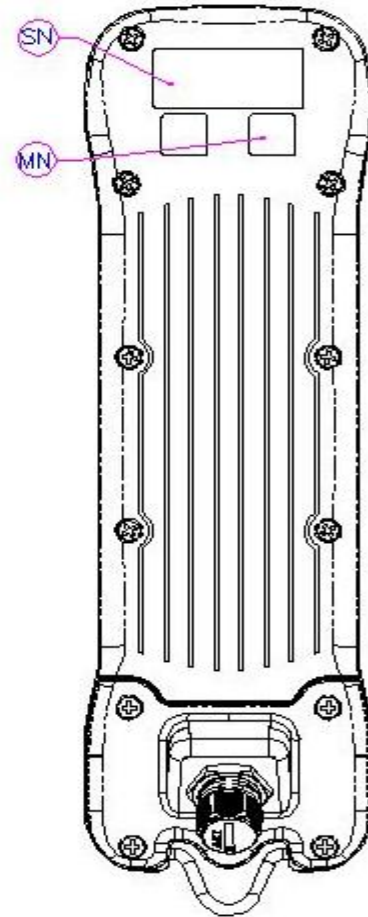
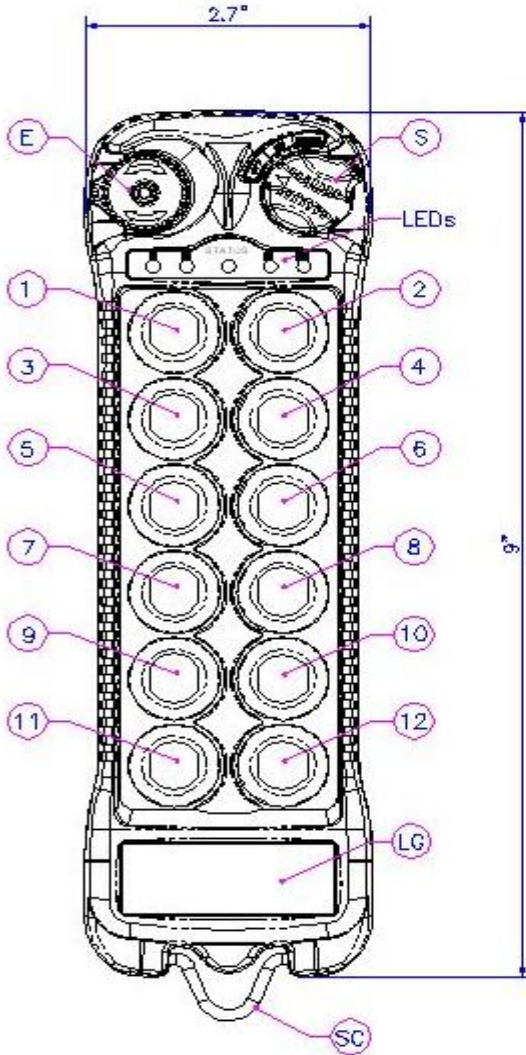

LAYOUT OF FLEX 12 BUTTON

- | | | |
|-------------------------------|---------------------|------------------------|
| E. Emergency Stop Button | 6. Push Button #6 | SC. Strap Ring |
| S. Removable Power Key Switch | 7. Push Button #7 | SN. System Information |
| 1. Push Button #1 | 8. Push Button #8 | MN. Machine Number |
| 2. Push Button #2 | 9. Push Button #9 | LG. Company Logo |
| 3. Push Button #3 | 10. Push Button #10 | |
| 4. Push Button #4 | 11. Push Button #11 | |
| 5. Push Button #5 | 12. Push Button #12 | |

P.O. Box 13615
Milwaukee, WI 53213
Toll-Free Phone 800.288.8178
Toll-Free Fax 800.298.3503

N49 W13650 Campbell Drive
Menomonee Falls, WI 53051
Phone 262.783.3500
Fax 262.783.3510

Enrange Facility
#5 Four Coins Drive
Canonsburg, PA 15317
Phone 262.783.3500
Fax 262.783.3510

Canada Facility
2610 Dunwin Drive
Mississauga, Ontario
L5L 1J5 Canada
Toll Free Phone:
800.792.7253
Fax: 905.828.5707

www.magnetekmobilehydraulic.com

Brochure No. Flex Pro Tethered
Tech Specs