

# IQAN-TOC8

## Instruction book

Publ no HY33-8304-IB/UK  
Edition 2011-08-10

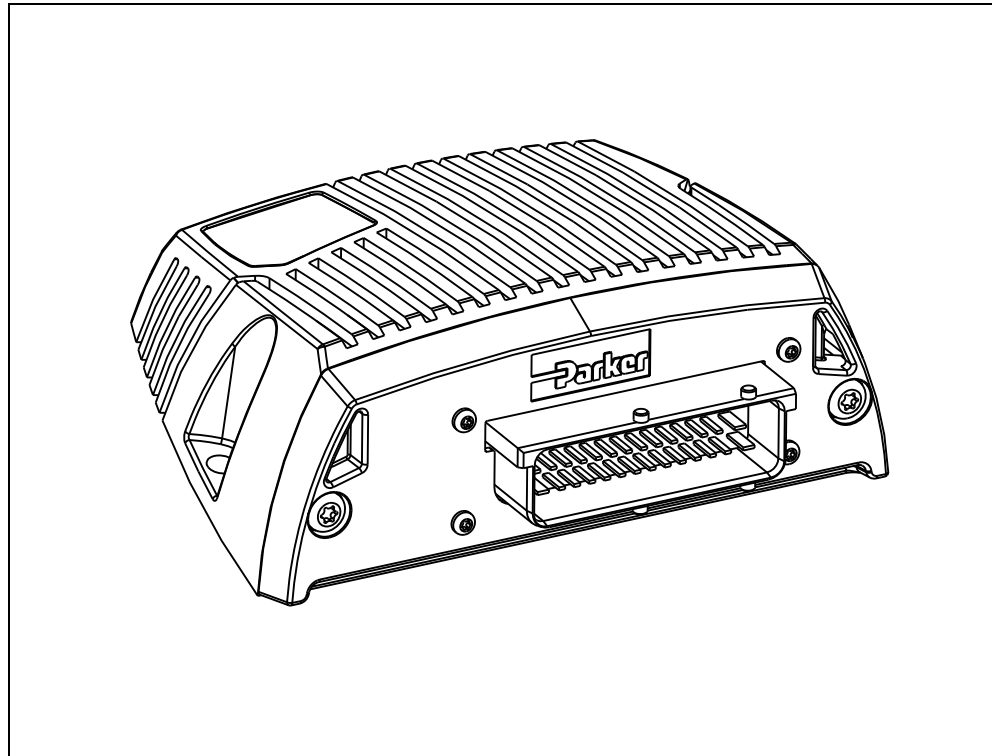

GS Global Resources • 1-800-261-8735 • [gsglobalresources.com](http://gsglobalresources.com)  
926 Perkins Drive, Mukwonago, WI 53149

© GS GLOBAL RESOURCES, INC. ALL RIGHTS RESERVED.



ENGINEERING YOUR SUCCESS.

<b>1</b>	<b>Introduction</b>	<b>1</b>
	Warnings	1
	Overview of relevant documentation	2
<b>2</b>	<b>Precautions</b>	<b>3</b>
	Read This	3
<b>3</b>	<b>Product description</b>	<b>5</b>
	IQAN-TOC8	5
<b>4</b>	<b>Safety</b>	<b>6</b>
	Internal diagnostics	6
	CAN-bus interruption	6
	Current check	6
	Emergency stop	6
<b>5</b>	<b>Mounting</b>	<b>7</b>
	Mounting the unit	7
<b>6</b>	<b>Installation</b>	<b>8</b>
	Connector C1	8
	Supply voltage	9
	Communication	10
	Reference voltage, VREF	11
	Voltage inputs	12
	Frequency inputs	15
	Current outputs	16
	Digital outputs	17
	PWM outputs	19
<b>7</b>	<b>Start-up</b>	<b>20</b>
	Start-up procedures	20
<b>8</b>	<b>System Diagnostics</b>	<b>21</b>
	<b>Appendix A</b>	<b>22</b>
	IQAN-TOC8 Technical Overview	22
	<b>Appendix B</b>	<b>25</b>
	Error codes, messages and actions	25
	<b>Appendix C</b>	<b>28</b>
	Dimensioning of the IQAN-TOC8 module	28

# 1 Introduction

These instructions are to be used as a reference tool for the vehicle manufacturer's design, production, and service personnel.

The user of these instructions should have basic knowledge in the handling of electronic equipment.

## Warnings

Sections marked with a symbol in the left margin, must be read and understood by everyone using the system, carrying out service work, or making changes to hardware and software.

The different symbols used in this manual are defined below.



### WARNING

Sections labeled *WARNING* with a caution symbol in the left margin, indicate that a hazardous situation exists. We use warnings, marked with the warning symbol, in two ways.

- As a strong recommendation about work practices when using the product in the machine (e.g. routines when updating an application). This use is common to the term 'hazardous situation', that a person is exposed to a hazard.
- As a way of pointing out important information for the machine designer that in some way relates to safety. This includes the design of the physical machine, and also the application program being developed for the control system.

Not all document sections that contain information about safety are marked with a warning symbol (there would be warnings everywhere). Failure to comply with the recommendations can cause unintentional, and unexpected behavior of the control system. This can potentially cause death, serious injury or property damage.



### NOTICE

Sections labeled *NOTICE* with a notice symbol in the left margin, indicate there is important information about the product. Ignoring this could result in less than optimal performance, or damage to the product.

Contact the manufacturer if there is anything you are not sure about or if you have any questions regarding the product and its handling or maintenance.

The term "manufacturer" refers to Parker Hannifin Corporation.

## Overview of relevant documentation

The following publications are relevant for users of this product.

The main documentation contains information that is not found elsewhere.

The additional documentation contains product information in a compact format, for details on the information found in those documents, consult this manual.

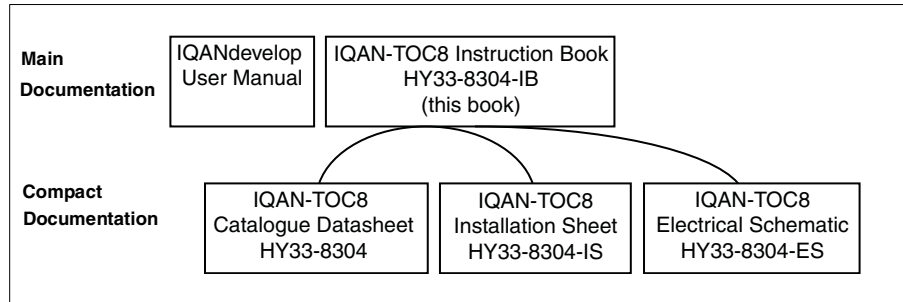

The IQAN-TOC8 module documentation system.

## 2 Precautions

Work on the hydraulics control electronics may only be carried out by trained personnel who are well-acquainted with the control system, the machine and its safety regulations.



### **WARNING**

Make sure that you have sufficient knowledge before designing, modifying or servicing the control system.

Read the relevant sections of this document before conducting any work on the control system.



### **WARNING**

This product is not field repairable.



### **NOTICE**

As much as possible of the welding work on the chassis should be done before the installation of the system. If welding has to be done afterwards, the electrical connections on the system must be disconnected from other equipment. The negative cable must always be disconnected from the battery before disconnecting the positive cable. The ground wire of the welder shall be positioned as close as possible to the place of the welding. The cables on the welding unit shall never be placed near the electrical wires of the control system.

## Read This

### **Design of control system**



### **WARNING**

Risk of injury may be introduced by design of control system!

This product is designed to control hydraulic outputs. The control application must be designed using basic safety principles so that unintentional movement is avoided.

The machine must be equipped with an emergency stop that stops all movement. Please refer to see section Emergency stop, on page 9.

### **Before you start**

Read this document, as a minimum sections 1-7

Read the IQANdevelop software user manual section on 'application safety'.

## **Start-up, maintenance, and diagnostics**

For all personnel carrying out installation, commissioning, maintenance or troubleshooting.



### **WARNING**

Work on the hydraulics control electronics may only be carried out by trained personnel who are well-acquainted with the control system, the machine and its safety regulations.

### **Before you start,**

Read see section Start-up, on page 20.

### **Additional information for service**

Mounting and maintenance instruction book.

### **Additional information for diagnosing the system**

Read see section System Diagnostics, on page 21, and see Appendix B, on page 25, in this document.

Use the IQANdevelop software user manual as a reference.

## 3 Product description

### IQAN-TOC8

The IQAN-TOC8 is a stand alone controller designed for controlling hydraulic systems in vehicles and machinery, using 12/24 Vdc power supply.

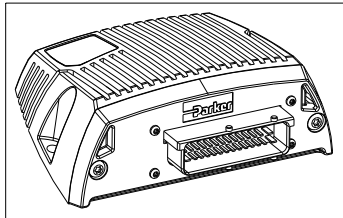

The IQAN-TOC8 controller.

#### Input

The IQAN-TOC8 has ten (10) inputs. These can be used as *voltage inputs* for connection of 0-5 Vdc signals or as *digital inputs*. VIN A thru VIN D can be configured as *frequency inputs* for measuring frequency. *Voltage inputs* and *frequency inputs*, share positions, see below.

---

(10) Voltage inputs VINA, VINB, VINC, ....., VINJ

or

(10) Digital inputs DINA, DINB, DINC, ....., DINJ

or

(4) Frequency inputs FINA, FINB, FINC, FIND & (6) Voltage inputs VINE -VINJ

---

#### Output

The IQAN-TOC8 has 2 double *current outputs* for controlling proportional valves or devices. The unit has 6 *digital outputs* for on/off valves, or 3 double *PWM outputs* (Pulse Width Modulation) for controlling standard proportional and Pulsar™ type valves. Digital and PWM outputs share positions, see below.

---

2 double Current outputs

6 Digital outputs, or 3 double PWM outputs

---

In order to increase the performance of the current outputs when controlling proportional valves, both the *dither frequency* and the *dither amplitude* can be adjusted. The *digital output channels* also have *PWM*, *soft start* and *peak & hold* features available.

#### CAN related functions

IQANsimulate software uses the CAN-bus (CAN = Control Area Network) to communicate with the controller when proving applications off of the machine (requires NI CAN card). The CAN-bus may be used by the TOC8 for SAE J1939 communication with engine electronics and for system control.

## 4 Safety

### Internal diagnostics

The module performs a number of self-checks that improve safety. Checks include monitoring of voltage supplies, checksums on memory and a watchdog that monitors software execution. The module is using a real time operating system which supervises software execution.

If a critical error is detected, the module is stopped, with CAN-bus and outputs off.

### CAN-bus interruption

The IQAN-TOC8 module monitors the CAN-bus (when used for SAE J1939) for interruptions in communication.

An error will be presented with a related blink code on the IQAN-TOC8 status LEDs.

### Current check

For the proportional outputs when used in current mode, a current check is performed. If an error is detected, this will be indicated on the module, and the output will shut off. The module can detect open-circuit, short-circuit to +BAT/-BAT or short-circuit to other proportional output and return pins.

### Emergency stop



#### **WARNING**

Risk of injury!

The emergency stop must disconnect the power supply to the module; do not connect the emergency stop as a signal input only.

The emergency stop must be installed so that the risk of reverse feed of the module is avoided, see section Emergency stop, on page 9.

## 5 Mounting

### Mounting the unit

The IQAN-TOC8 should be mounted according to the following instructions:

- Locate the unit eliminating the risk for the cabling to be folded, crushed or damaged in any way. Ensure the cabling cannot pull, twist or induce side-load on the connector.
- Locate the unit so that severe physical impact is avoided, e.g. impact from falling objects or the unit being used as a step.
- Locate the unit so that air can circulate to eliminate excess heat. Ensure that no external heat, e.g. from the engine or heater, is transferred to the control.
- Locate the unit to protect it from high pressure washing or similar.
- Locate the unit so that the cable connector is facing down.
- Locate the unit so that the LEDs are visible.

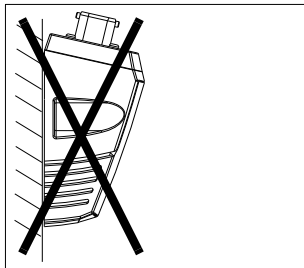

Non-approved placing.



#### NOTICE

The IQAN-TOC8 must not be placed in any marine-related or similar continuously damp environment without external protection.

## 6 Installation

### Connector C1

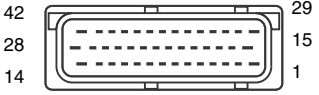
<b>Connector kit</b>	<b>Parker no. 5031063</b>				
Housing	Amp no. 1-963226-1				
Casing	Amp no. 0-965643-1				
Plane sealing, 42 p	Amp no. 963225-1				
Pin types*	Amp no. 963711-2 (MT)	Amp no. 929938-1 (JPT)	<p>*= The connector contains two types of terminals; MT (Micro Timer) and JPT (Junior Power Timer).</p>		
Cables	0,75-1,0 mm <sup>2</sup> (MT)	1,5-2,5 mm <sup>2</sup> (JPT)			
Seals	Amp no. 963530-1 (MT)	Amp no. 828905-1 (JPT)			
Plugs (empty pos.)	Amp no. 963531-1 (MT)	Amp no. 828922 (JPT)			
<b>IQAN toolkit</b>	<b>Parker no. 5031061</b>				
<b>Pos</b>	<b>Signal name</b>	<b>Pos</b>	<b>Signal name</b>	<b>Pos</b>	<b>Signal name</b>
1	not used	15	-BAT	29	-BAT2
2	+VREF-A	16	CAN-H	30	CAN-L
3	VIN-A/DIN-A/FIN-A	17	COUT-A	31	COUT-A
4	-VREF-A	18	CRET-A+	32	CRET-A-
5	VIN-E/DIN-E	19	COUT-B	33	COUT-B
6	VIN-B/DIN-B/FIN-B	20	CRET-B+	34	CRET-B-
7	VIN-F/DIN-F	21	DOUT-A/ PWMOUT-A	35	DOUT-C/ PWMOUT-C
8	VIN-G/DIN-G	22	DOUT-B/ PWMOUT-B	36	DOUT-D/ PWMOUT-D
9	VIN-C/DIN-C/FIN-C	23	DOUT-E/ PWMOUT-E	37	ALARM
10	VIN-H/DIN-H	24	DOUT-F/ PWMOUT-F	38	GND (DATA)
11	+VREF-B	25	DATA-OUT	39	READY-OUT
12	VIN-D/DIN-D/FIN-D	26	DATA-IN	40	BSL-IN
13	-VREF-B	27	VIN-I/DIN-I	41	VIN-J/DIN-J
14	not used	28	+BAT (+12 V, +24 V)	42	+BAT2 (+12 V, +24 V)

Unshaded positions are Junior Power Timer pins. Shaded positions are Micro Timer pins.  
See above for wire, seal, pin number and crimping tool information.  
The IQAN tool kit is found in the 'IQAN accessories' datasheet.

## Supply voltage

Before any installation of the IQAN system can take place, make sure the ignition lock is turned off and the battery is disconnected.

### Emergency stop

Make sure an *Emergency Stop* disconnecting the power supply, is easily accessible at any time. The figure below shows how to connect the emergency stop.

### Connecting of Supply Voltage

The supply voltage, should be within the operating interval, see Appendix A, on page 22. Connect the supply voltage to +BAT, position 28 and -BAT, position 15. Protect the control by using a fuse. Requisite fuse level should be 20 A, fast (F).

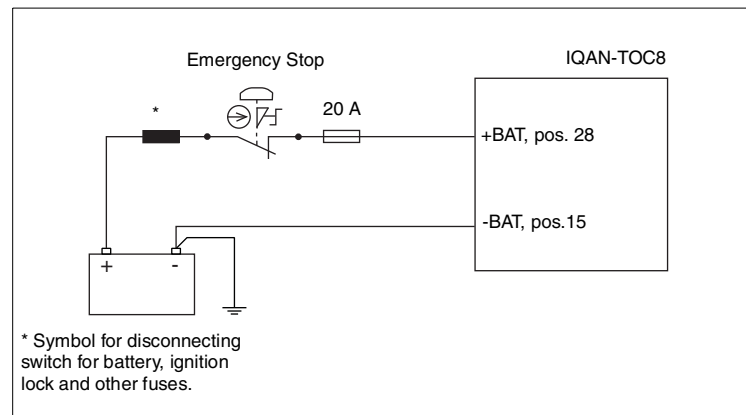

Connecting the emergency stop and voltage supply.



### NOTICE

Do not use the chassis as the negative terminal.

### Supplying a high current draw system

If the IQAN-TOC8 is used to control several digital outputs simultaneously, it is recommended to source power thru the +BAT2 and -BAT2 positions in addition to the +BAT and -BAT. Change the fuse to 30A, fast.

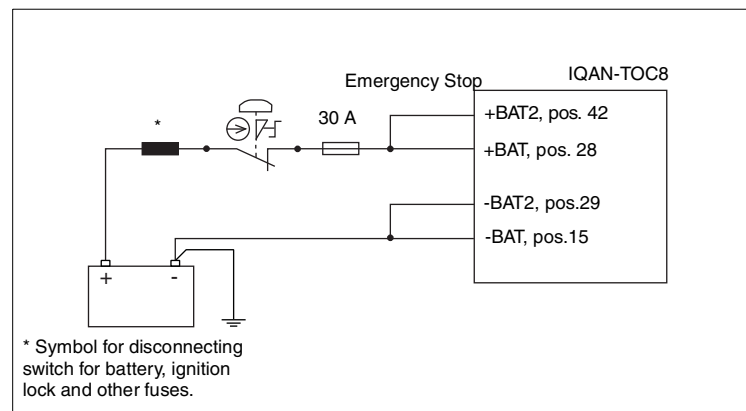

Connecting the emergency stop and voltage supply.

## Communication

### RS232 and modem connection

The IQAN-TOC8 has an *RS232 interface* for communicating with the programming software, IQANdevelop. A flying lead, panel-mount, adapter cable, 5030089, may be connected to the TOC8 to provide an HR12 connector interface. This will match to the PC communication cable provided in the IQANdevelop software package.

Instead of using recommended Parker adapter cable 5030089, a DB9-F serial connector may be wired to connect directly to a PC. The basic wiring for use of a DB9-F serial connector is shown below.

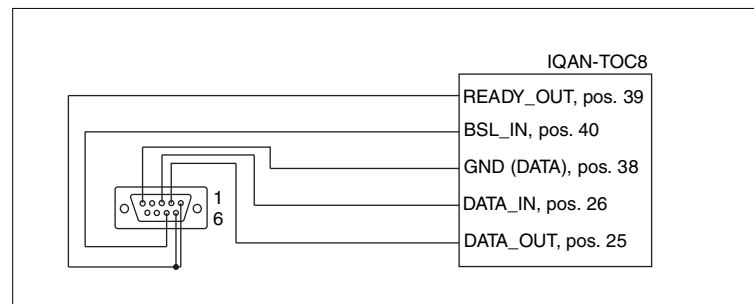

Connecting DB9-F for RS232 usage.

When using the recommended Parker adapter cable, 5030089, the connection from TOC8 to PC can be made with the IQANdevelop included cable, 5030024, and from TOC8 to modem with a separately purchased cable, 5030080.



### NOTICE

The 'Remote Diagnostic' cable 5030080 must be used when connecting a modem to the TOC8.

Use of the MDM-RS232 cable 5030024 may damage the modem.

### Using a modem

#### Start modem communication as follows:

- Attach the modem to the TOC8.
- Power up the modem first, then power up or reset the TOC8.
- Wait 45 seconds for the modem to initialize. The TOC8 will blink a double fast yellow code to indicate the modem is attached.
- Dial up the modem -- the TOC8 will automatically answer. A fast yellow-red double blink indicates ringing.
- If a 'Reset Master' command is sent or a new application is downloaded, the TOC8 will reset. Modem communication will not cease but with some equipment the blink code will change from the fast double yellow blink code to the normal status single blink.

### CAN connection

The module has a CAN interface that can be used to connect to SAE J1939 or similar bus for communication between IQAN-TOC8 and other systems.

### Connecting to CAN interface

The interface is connected from the engine's SAE J1939 interface to the CAN\_H and the CAN\_L.

#### EXAMPLE

Connect the SAE J1939 CAN\_H and CAN\_L pins to the CAN\_H, position 16 and the CAN\_L, position 30 on the IQAN-TOC8.

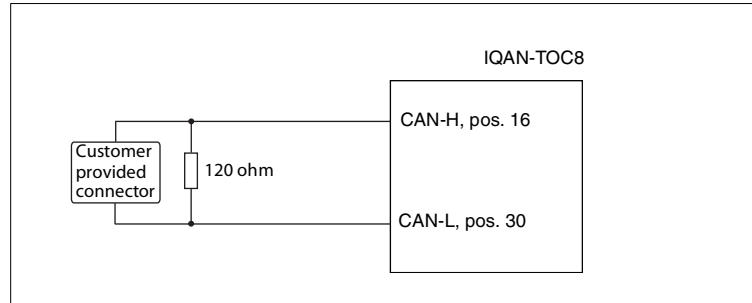

Connecting a SAE J1939 interface to the TOC8 CAN hub.

### Reference voltage, *VREF*

The IQAN-TOC8 is internally equipped with two voltage regulators to generate the reference voltages *VREF A* and *VREF B*. These reference voltages will feed different kinds of sensors.

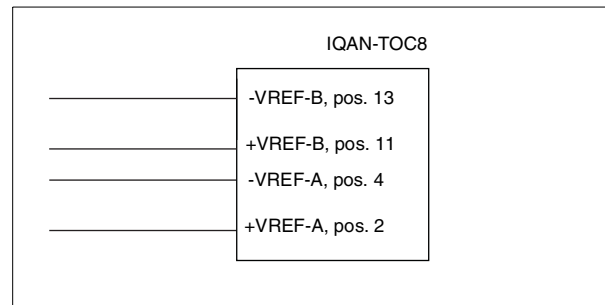

VREF positions.



#### NOTICE

Maximum load for the VREF A and VREF B is different according to 12/24 Vdc power supply, see Appendix A, on page 22.

## Voltage inputs

### Connecting sensors to the voltage inputs

The sensor signal range must be 0-5 Vdc. To detect signal errors such as short circuits or interruptions the active signal range should be within 0.5-4.5 Vdc.

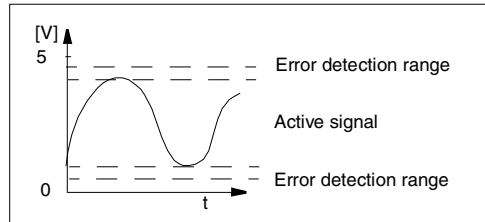

Active signal range.

The current consumption related to the voltage input is negligible.

The positive terminal of the sensor is connected to the +VREF position and the corresponding negative terminal to the -VREF position. The sensor signal is connected to appropriate VIN position.

#### EXAMPLE

Connect the positive and negative terminals of the position sensor to +VREF-A, position 2, and -VREF-A, position 4, respectively. Then connect the sensor signal to VIN-A, position 3.

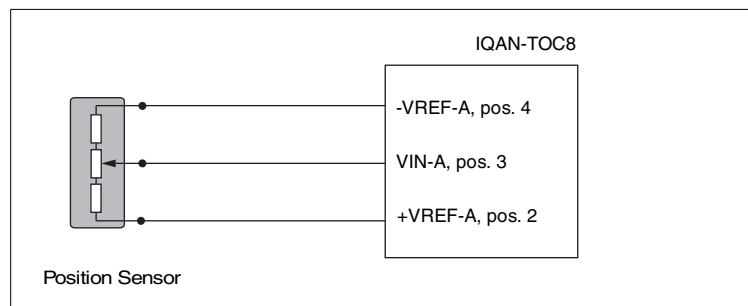

Connecting VREF-A and sensor signal VIN-A.



#### NOTICE

The negative terminal of the sensor must not be connected to the chassis. Maximum load for each VREF position, see Appendix A, on page 22.

### Connecting a 2-wire temperature sensor to voltage in

When you connect a PTC (positive temperature coefficient) temperature sensor you may need to use a pull up resistor on the input signal. Please check the technical data for your specific temperature sensor.

#### EXAMPLE

Connect the negative terminal of the temperature sensor to -VREF-A, position 4, and the signal to VIN-A, position 3. The pull up resistor will be connected between VIN-A, position 3 and +VREF-A, position 2.

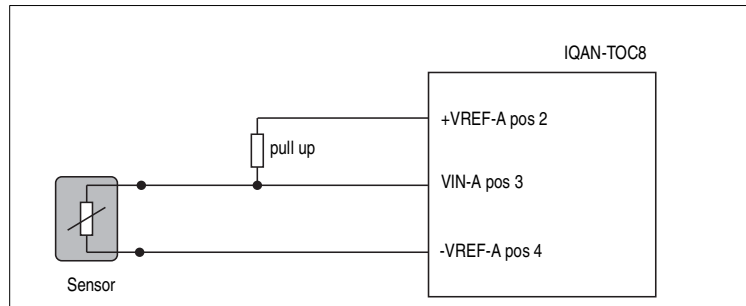

Connecting -VREF-A and temperature sensor signal VIN-A.

The pull up resistor value for a  $R_{25}=2000\Omega$  PTC sensor is  $4,7\text{ K}\Omega$ .

### Connecting switches to the voltage inputs

Switches could be connected to the voltage inputs, to create a digital on/off signal. The switches may be connected to +VREF and VIN respectively. The current consumption for the voltage input is negligible.

It is also possible (recommended) to connect system voltage +BAT to the voltage input through a switch.

#### EXAMPLE

Connect the positive and negative terminals of the switch to +VREF-A, position 2, and VIN-A, position 3, respectively.

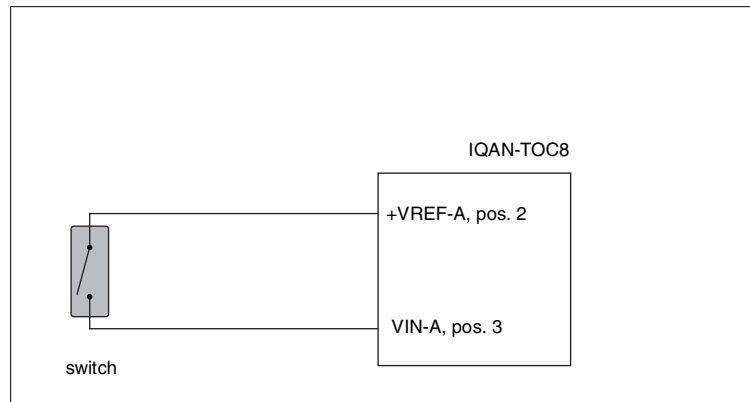

Connecting a switch to VIN-A.



#### NOTICE

Maximum load for each VREF position, see Appendix A, on page 22.

#### EXAMPLE

Connect the positive and negative terminals of the switch to +BAT and VIN-A, position 3, respectively.

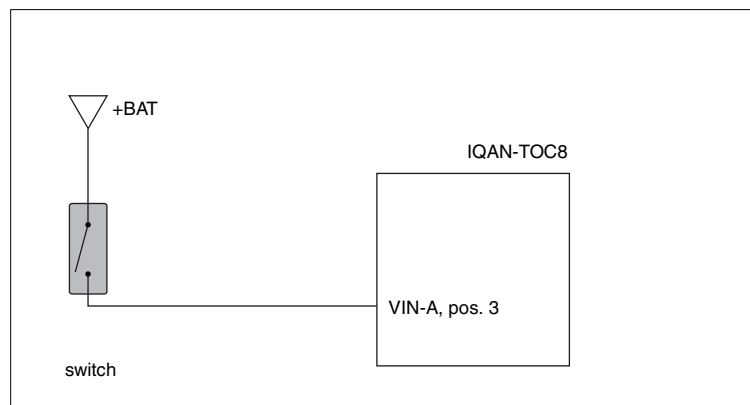

Connecting a switch to VIN-A and +BAT.

## Frequency inputs

### Connecting sensors to the frequency inputs

For the frequency ranges and trigger levels, see Appendix A, on page 22.

#### Simple frequency sensor

The positive terminal of the frequency sensor is connected to the +VREF and the negative terminal to the -VREF respectively.

The sensor signal is connected to a FIN position.

If the current consumption for the sensor exceeds the maximum load for the VREF, the sensor could be connected to the BAT positions.

#### EXAMPLE

Connect the positive and negative terminals of the frequency sensor to +VREF-A, position 2, and -VREF-A, position 4, respectively. Then connect the sensor signal to FIN-A, position 3.

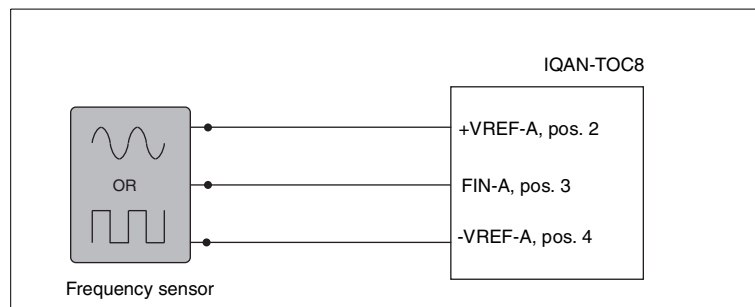

Connecting of frequency sensor.



#### NOTICE

The negative terminal of the sensor must not be connected to the chassis. Maximum load for each VREF position, see Appendix A, on page 22.

## Current outputs

The current output signals control proportional valves and devices. For the current range see Appendix A, on page 22.

### Dither frequency and amplitude

To obtain the best performance from proportional valves the control produces a direct current (DC) with a dither. The *dither frequency* and the *dither amplitudes* can be adjusted in IQANdevelop software. Depending on what kind of valve is to be used, a certain recommended dither frequency/amplitude set-up can be supplied by Parker Hannifin Corporation in order to obtain an optimized valve hysteresis. Both frequency and amplitudes will then be set using IQANdevelop software.

### Connecting loads to current outputs

Connecting a load, e.g. one proportional valve, to the current output is done by using the COUT/CRET pair positions.

#### EXAMPLE

*Positive direction:*

Connect the proportional valve to the COUT-A, position 17 and the CRET-A+, position 18 respectively.

*Negative direction:*

Connect the proportional valve to the COUT-A, position 31 and the CRET-A-, position 32 respectively.

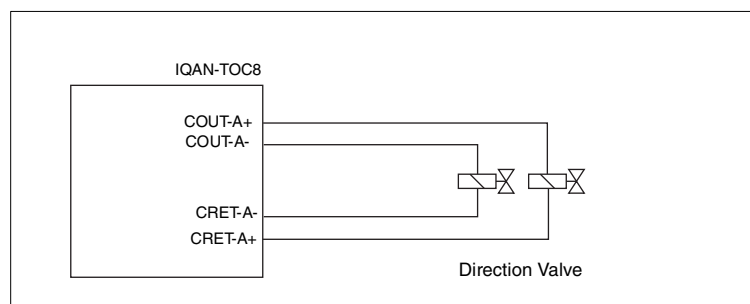

Connecting a load to the current output.

## Digital outputs

The digital outputs control relays and on/off valves. For the maximum load per output see Appendix A, on page 22.

### Soft start

*Soft start* is used whenever start-up is required to be smoother than the normal procedure offers. A desired ramp function provides the smoother start-up according to the figure below. The ramp function is set up in IQANdevelop software.

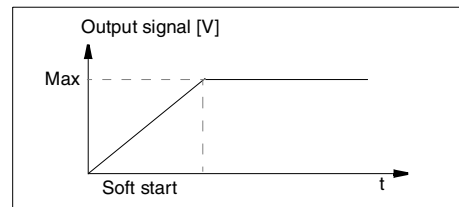

The Soft start function.

### Peak and Hold

The *Peak and Hold* feature makes it possible to decrease the voltage to the valve solenoid. Shortly after a valve has been activated, the voltage can be decreased to a lower level, sufficient to maintain the position of the valve, but also reducing the heat generated in the valve (due to this lower voltage).

The reducing of heat, is the primary reason for selecting the *Peak and Hold* feature. Both the peak time and the hold value are set up in IQANdevelop software.

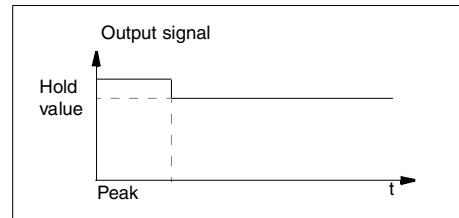

The Peak and Hold value voltage graph.

### Connecting loads to digital outputs

Connecting of loads to the digital outputs such as on/off valves is done by using the DOUT positions and chassis as ground.

#### Protection against voltage transients

A clamping diode must be placed between the digital output and ground, as close to the load as possible, to protect the output against high voltage transients.

For example: use diode: 1N5408 (3A/1000V).

Depending on load, other clamping diodes might be used instead.

#### EXAMPLE

Connect the on/off valve to the digital output using the DOUT-A, position 21, and the chassis as ground.

A clamping diode must be placed as close to the load as possible, see figure below.

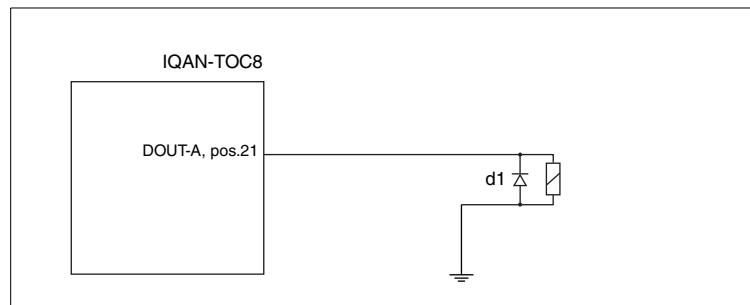

Connecting a load to the digital output.

If the load is controlled in parallel with another system, the digital output shall be protected with a diode.

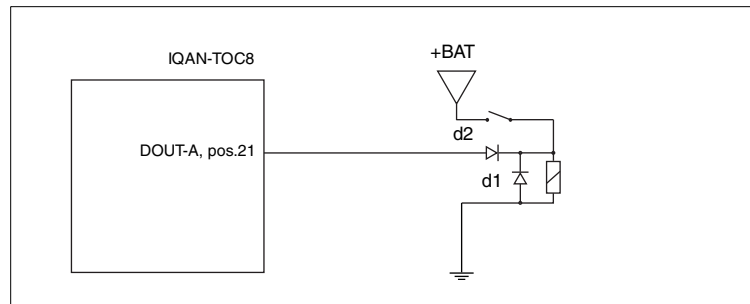

Digital output protected with a diode.

## PWM outputs

The PWM outputs (Pulse Width Modulation) control pilot valves. Maximum load should not exceed 3.0 A per output.

### Connecting loads to PWM outputs

The load is connected between the PWMOUT and the chassis ground. Maximum load per output, see Appendix A, on page 22.

### Protection against voltage transients

A clamping diode must be placed between the output and ground, as close to the load as possible, to protect the output against high voltage transients.

For example: use diode: 1N5408 (3A/1000V).

Depending on load, other clamping diodes might be used instead

#### EXAMPLE

Positive direction:

Connect the load between the PWMOUT-A, position 22, and the chassis as ground.

*Negative direction:*

Connect the load between the PWMOUT-B, position 21, and the chassis as ground.

A clamping diode will be placed as close to the pilot valve as possible.

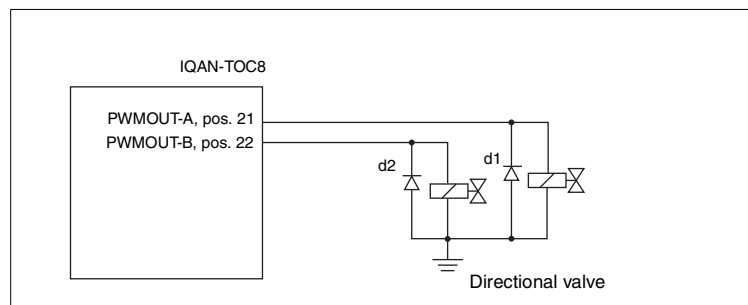

Connecting a load to the PWM output.

## 7 Start-up

### Start-up procedures

This chapter contains instructions for action to be taken in connection with the initial start.



#### **WARNING**

Risk of injury!

If the control system is not fitted properly, the machine could move uncontrollably. The machine's engine shall not be started before the control system is completely fitted and its signals are verified.

### Starting the control system

#### **Start the control system as follows:**

- Prior to start, all modules and cables are to be fitted correctly.
- Check fuses, i.e. make sure that the supply voltage to the modules is equipped with the correct fuse.
- Make sure that connections for supply voltage and return lines are correct in the cable's conductor joint.
- Make sure an emergency stop is installed.  
The emergency stop should disconnect the supply voltage to all modules. Alternatively, the emergency stop may also shut off the diesel engine or a dump valve, and with that, depressurize the hydraulic system.

### Prepare for system start



#### **WARNING**

Make sure no one is in dangerous proximity to the vehicle to avoid injuries when it starts.

#### **Prepare for the initial system start as follows:**

- The engine for the hydraulic system's pump shall be in off position.
- Make sure that all connectors are properly connected.
- Turn on the control system.
- Make sure that voltage is being supplied to all modules; the power/status diode shall be illuminated on all modules. Also, make sure that the master is in contact with all modules by reading the master's display.
- Make sure the emergency stop is functioning properly.

### Start the system

#### **Start the system as follows:**

- Start the engine for the hydraulic system's pump, assuming that the above mentioned inspections have been carried out and shown correct values.

Calibrate and adjust input and output signals according to the instructions related to the master menu system and check each and every output function carefully.

## 8 System Diagnostics

The yellow blinking LED on the top of the unit indicates normal status. The TOC8 control indicates *error status* through the red blinking LED and a yellow secondary blinking pattern.

This gives an immediate indication as to the cause of an error.

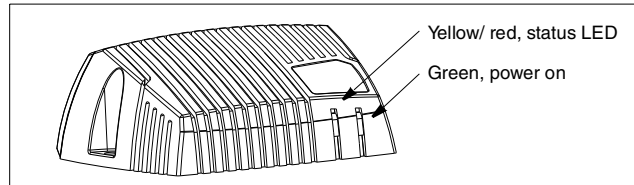

The location of the LED indicators on the IQAN-TOC8 control.

The green LED indicates power on. The yellow/red LED, will be blinking a pattern showing status, and also when an error has been detected. To get further information about the error messages, see Appendix B, on page 25.

## Appendix A

### IQAN-TOC8 Technical Overview

#### Absolute maximum ratings

$T_A = +25\text{ °C}$  (unless otherwise specified)

Parameter	Limit values			Unit	Remark
	min.	typ.	max.		
Operating ambient temperature, $T_A$	- 40		+80	°C	
Storage temperature	- 40		+100		
Voltage supply, $V_{BAT}$	6		36	V	
Analog input levels, $V_{IN}$	-36		36	V	
Digital input levels, $D_{IN}$	-36		36	V	
Load current, $C_{OUT}$				A	internally limited
Load current, $D_{OUT}$				A	internally limited
Load current, total all outputs			20	A	

#### Environmental ratings

Parameter	Limit values			Unit	Remark
	min.	typ.	max.		
EMI ISO 11452-2 ISO 14982 ISO11452-4 ISO7637-2			50 50	V/m V/m	
ESD EN 61000-4-2 (external)			15	kV	
CAN-bus length <sup>a</sup>			100	m	
Mechanical environment IEC 60068-2-64 Fh (random, 10 - 250 Hz) IEC 60068-2-27 Es (shock, 11ms) IEC 60068-2-29 Eb (bump, 6ms)			0.1 40 40	$g^2/Hz$ g g	
Climate environment IEC 60068-2-18 Rb2 (water) IEC 60068-2-30 Db (var1: damp, cyclic) IEC 60068-2-3 Ca (damp, heat steady state) IEC 60068-2-2-Bb (heat) IEC 60068-2-1 Ab (cold) IEC 60068-2-14 Nb (change of temperature)			3 72 240 72 16 10 x 6	min hour hour hour hour hour	30kPa, 12.5 l/min 25-55°C, 95% RH 44°C, 93% RH 70°C -30°C -30 - 70°C
Chemical environment IEC 60068-2-52 Kb (salt mist, cyclic)			72	hour	

a. CAN is only used with IQANsimulate, SAE J1939 or during factory testing of the IQAN-TOC8 control.

### Operation

-40 °C < T<sub>A</sub> < +70 °C (unless otherwise specified)

Parameter	Limit values			Unit	Remark
	min.	typ.	max.		
Ambient temperature (no load), T <sub>A</sub>	- 40		+75	°C	
Voltage supply, V <sub>BAT</sub>	9		34	V	
Output voltage, VREF	4.9	5.0	5.1	V	
Maximum load current, VREF A, B V <sub>BAT</sub> = 14V V <sub>BAT</sub> = 28V			50 20	mA	VREF A+ VREF B
Current supply V <sub>BAT</sub> = 14V V <sub>BAT</sub> = 28V		90 105		mA	outputs = off

### I/O

-40 °C < T<sub>A</sub> < +70 °C (unless otherwise specified)

Parameter	Limit values			Unit	Remark
	min.	typ.	max.		
<b>VIN (Voltage input)</b>					
Signal range low		0	0.05	V	
Signal range high	4.9	5.0	5.1	V	
Input resistance		62		kΩ	
Signal resolution		5		mV	
Total unadjusted error		15	35	mV	(vref as source)
<b>FIN (Frequency input)</b>					
Trigger level high	4.0			V	@1kHz
Trigger level low			1.8	V	@1kHz
Frequency range	2		10000	Hz	5V source
Pulse width	10			ms	
Frequency resolution < 1kHz < 5kHz < 10kHz		0,8 20 80		Hz	$\frac{f^2}{1, 25 \cdot 10^6}$

**I/O (cont.)**

Parameter	Limit values			Unit	Remark
	min.	typ.	max.		
<b>DOUT (Digital output)</b>					
Load current each channel active (A,B,C,D,E,F)			3	A	
Load current one channel in each group (A or B, C or D, E or F)			4	A	The DOUT are divided into three groups.
Voltage drop ( $V_{BAT} - V_{DOUT}$ ) load $I_L = 0,5A$ load $I_L = 3A$		0.2 0.8		V	
Short Circuit current limit		6		A	
<b>PWMOUT (Pulse Width Modulation output)</b>					
Load current each channel active (A,B,C,D,E,F)			3	A	
Load current one channel in each group (A or B, C or D, E or F)			4	A	The PWMOUT are divided into three groups.
Voltage drop ( $V_{BAT} - V_{DOUT}$ ) load $I_L = 0,5A$ load $I_L = 3A$		0.2 0.8		V	
Short Circuit current limit		6		A	
PWM frequency	25		2000	Hz	
<b>COUT (Current out)</b>					
Signal range	50		1800	mA	
Resolution		0.7		mA	
Load	4			W	
Total unadjusted error			$\pm 5$	mA	$T_A = 25^\circ C$
Deviation between modules <sup>a</sup>		$\pm 2$		mA	
Power supply rejection $V_{BAT} = 9... 18V$ $V_{BAT} = 24... 34V$		1 1		mA	$R_L = 6 W - 25 W$
Load regulation $V_{BAT} = 14V, R_L = 4... 9 W$ $V_{BAT} = 28V, R_L = 22... 34 W$		$\pm 1$ $\pm 3$		mA	
Dither frequency	25		150	Hz	
Dither amplitude	0		500	mA	

a. In case of switching modules, note that the current values differs between different modules.

## Appendix B

### Error codes, messages and actions

If one of the following errors is detected, a message will be presented via the LED error codes on the control. In some cases, the control will stop operating or at least shut down the outputs, to increase safety.



#### WARNING

Don't use the machine if an error message or error code is activated.

#### LED indicator showing different TOC8 modes

Status	Blink (yellow light)
Invalid application	
Modem connected	
Modem ring (yel./red)	
Normal operation	
IQANSimulate (red)	
Fatal software (red)	

Error code	Error	Primary Blink (red) Error category	Secondary Blink (yellow) Error description
1	Output error		
1	Input error		
1	VREF error		
1	Supply or checksum		
2	Temp. error		none
3	Wrong modem SIM code		
3	Missing SIM code		

The following sections will present what measures to take for different error situations.

---

**ERROR: OUTPUT HIGH**

<b>Situation</b>	<b>Error code</b>	<b>Action TOC8</b>	<b>Comment</b>
COUT: Current return low or high	Error 1-1	Active output shuts off.	Check wiring and loads
COUT: Both directions commanded	Error 1-1	Active output shuts off.	Check application
DOUT: Overload	Error 1-1	Active output shuts off.	Check load
PWMOUT: Both directions commanded	Error 1-1	Active output shuts off.	Check application
COUT/DOUT: Internal driver failure	Error 6	Active output shuts off.	Contact supplier

---

**ERROR: INPUT**

<b>Situation</b>	<b>Error code</b>	<b>Action TOC8</b>	<b>Comment</b>
VIN: > specified max or < specified min	Error 1-2	Active input goes to error value.	Check wiring and sensors

---

**ERROR: VREF**

<b>Situation</b>	<b>Error code</b>	<b>Action TOC8</b>	<b>Comment</b>
VREF_ < 4,9 V	Error 1-3	-	Check voltage
VREF_ > 5,1 V	Error 1-3	-	Check voltage

---

**LOW/ HIGH SUPPLY VOLTAGE**

<b>Situation</b>	<b>Error code</b>	<b>Action TOC8</b>	<b>Comment</b>
+BAT < 8,5 V	Error 1-4	-	Check voltage supply
+BAT > 34 V	Error 1-4	-	Check voltage supply

---

**ERROR: PARAMETER**

<b>Situation</b>	<b>Error code</b>	<b>Action TOC8</b>	<b>Comment</b>
Parameter error (checksum)	Error 1-4	-	Contact supplier

---

**HIGH TEMPERATURE**

<b>Situation</b>	<b>Error code</b>	<b>Action TOC8</b>	<b>Comment</b>
Internal temperature > max temp	Error 2	-	Check ambient temperature
Internal temperature sensor error	Error 6	-	Contact supplier

---

**ERROR: COMMUNICATION**

<b>Situation</b>	<b>Error code</b>	<b>Action TOC8</b>	<b>Comment</b>
Modem error (wrong SIM code)	Error 3-1	-	Enter proper code in IQANdevelop
Modem error (missing SIM code)	Error 3-2	-	Enter proper code in IQANdevelop

---

**ERROR: SOFTWARE**

<b>Situation</b>	<b>Error code</b>	<b>Action TOC8</b>	<b>Comment</b>
Software error	Error 6	The unit stops operating.	Contact supplier.

---

## Appendix C

### Dimensioning of the IQAN-TOC8 module

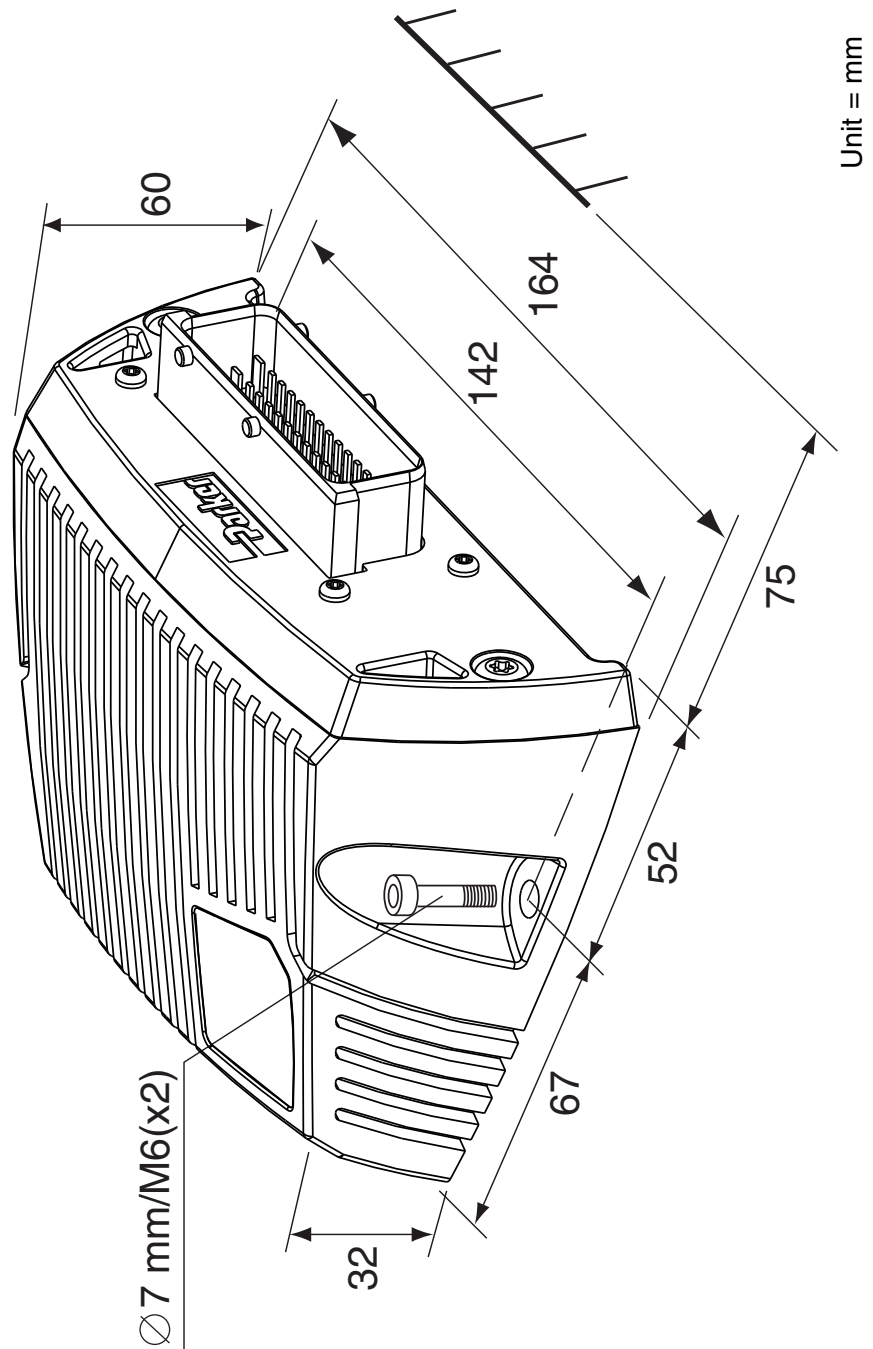

For latest information visit our website [www.iqan.com](http://www.iqan.com)

Information in this instructionbook is subject to change without notice

Publ no HY33-8304-IB/UK  
Edition 2011-08-10

**Parker Hannifin**  
Electronic Controls Division  
SE-435 35 Mölnlycke  
Sweden  
Tel +46 31 750 44 00  
Fax +46 31 750 44 21  
[www.parker.com](http://www.parker.com)

**Parker Hannifin**  
Electronic Controls Division  
1651 N. Main Street  
Morton, IL 61550  
USA  
Tel +1 309 266 2200  
Fax +1 309 266 6674

