

**POMPE A PISTONI ASSIALI PER CIRCUITO
CHIUSO A CILINDRATA VARIABILE**

***VARIABLE DISPLACEMENT
CLOSED CIRCUIT AXIAL PISTON PUMPS***

**AXIALKOLBENVERSTELLPUMPEN
FÜR DEN GESCHLOSSENEN KREISLAUF**

HM POB

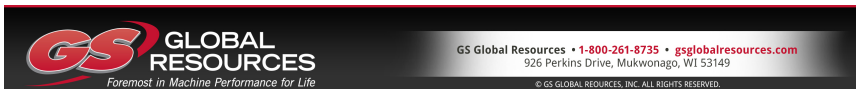

398SCP0023A01

HM POB

POMPE A PISTONI ASSIALI A CILINDRATA VARIABILE VARIABLE DISPLACEMENT AXIAL PISTON PUMPS AXIALKOLBENVERSTELLPUMPEN

Le pompe a pistoni assiali serie HM POB sono state concepite per operare in circuito chiuso. I vari sistemi di comando disponibili le rendono facilmente adattabili alle esigenze applicative sia per il settore industriale che per quello del mobile in generale.

Lo sviluppo di gruppi rotanti appositamente concepiti, unito ad uno studio accurato delle sezioni di passaggio dell'olio, consentono a queste pompe di raggiungere elevate velocità di rotazione, come quelle consentite dai moderni motori diesel, garantendo una elevata affidabilità per pressioni di funzionamento fino a 300 bar di picco.

Le pompe possono essere composte in versione tandem, utilizzando le opportune predisposizioni disponibili a richiesta.

Axial piston pumps series HM POB have been designed to operate in a closed circuit.

The available control systems make it easy to use these pumps in any application for industrial and mobile fields.

Development of rotating groups, especially designed, united to an accurate study of oil passage sections, allow high speed rotation, like required by modern diesel engines, giving extreme reliability for working peak pressure up to 300 bar. It is possible to couple tandem versions, by means of coupling flanges optionally available.

Die Axialkolbenpumpen der Serie HM POB wurden für den Betrieb im geschlossenen Kreislauf konzipiert.

Die verschiedenen lieferbaren Steuerungssysteme eignen sich sowohl für stationäre als auch für mobile Anwendungen im Allgemeinen.

Speziell entwickelte Zylinderblöcke mit optimalen Saugverhältnissen ermöglichen, wie von modernen Antriebsaggregaten gefordert, den Einsatz bei hohen Pumpendrehzahlen, wobei ein kontinuierlicher Arbeitsdruck mit einem Spitzenwert von 300 Bar gewährleistet ist. Unter Anwendung der auf Anfrage erhältlichen Anbauflansche können die Pumpen in der Tandemversion geliefert werden.

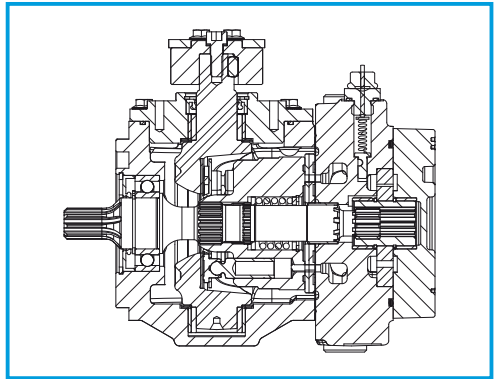
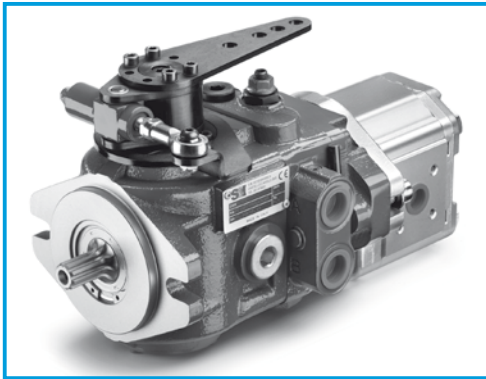

DATI TECNICI TECHNICAL DATA TECHNISCHE MERKMALE

GRUPPO GROUP BAUREIHE	CILINDRATA TEORICA NOMINAL DISPLACEMENT FORDERVOLUMEN		CONTINUA CONTINUOUS DAUER		PRESSIONE PRESSURE DRUCK		PICCO PEAK SPITZEN		VELOCITÀ DI ROTAZIONE SPEED DREHZAHL		MASSA WEIGHT GEWICHT	
	cm ³	in ³	bar	psi	bar	psi	bar	psi	MAX min ⁻¹	MIN min ⁻¹	kg	lbs
HM POB	7	0,43	250	3625	280	4060	300	4350	3600	500	8,5	18,7
	8	0,49	250	3625	280	4060	300	4350	3600	500	8,5	18,7
	9	0,55	250	3625	280	4060	300	4350	3600	500	8,5	18,7
	10	0,61	250	3625	280	4060	300	4350	3600	500	8,5	18,7
	11	0,67	250	3625	280	4060	300	4350	3600	500	8,5	18,7
	12	0,73	250	3625	280	4060	300	4350	3600	500	8,5	18,7
	13	0,80	250	3625	280	4060	300	4350	3600	500	8,5	18,7
	14	0,85	250	3625	280	4060	300	4350	3600	500	8,5	18,7
	16	0,98	250	3625	280	4060	300	4350	3600	500	8,5	18,7
	18	1,10	230	3335	250	3625	280	4060	3600	500	8,5	18,7

PRESSIONE CONTINUA: pressione media del normale range di pressioni di funzionamento
PRESSIONE INTERMITTENTE: pressione che può essere mantenuta per periodi brevi (circa il 10% del ciclo di lavoro)

PRESSIONE DI PICCO: pressione massima permessa regolata dalle valvole di max. 1-2% del ciclo di lavoro)

CONTINUOUS PRESSURE: average pressure of the normal operating pressure range

INTERMITTENT PRESSURE: pressure that can be maintained for short periods (for about 10% of the work cycle)

PEAK PRESSURE: maximum allowable pressure regulated by maximum relief valves (max 1-2% of the work cycle)

CONTINUIERLICHER DRUCK: durchschnittlicher Druck der normalen Betriebsdruckreihe

INTERMITTIERENDER DRUCK: Druck, der für kurze Zeitabschnitte beibehalten werden kann (etwa 10% des Betriebszyklus)

SPITZENDRUCK: zugelassener Höchstdruck, von den Hochdruckventilen geregelt (max. 1-2% des Betriebszyklus)



**POMPA DI ALIMENTAZIONE
BOOST PUMP
SPEISEPUMPE**

HM POB

HM POB	CILINDRATA DISPLACEMENT FORDERVOLUMEN		PRESSIONE PRESSURE DRUCK	
	cm ³	in ³	bar	psi
POMPA SINGOLA SINGLE PUMP PUMPE	5	0.30	12	174
POMPE TANDEM (una sovralimentazione) TANDEM PUMPS (one boost pump) MEHRFACHPUMPEN (eine Speisepumpe)	8	0.48	12	174
POMPE TANDEM (due sovralimentazioni) TANDEM PUMPS (two boost pumps) MEHRFACHPUMPEN (zwei Speisepumpen)	5+5	0.30+0.30	12	174

**MOMENTO POLARE DI INERZIA
INERTIAL MASS
TRÄGHEITSMOMENT**

approx. $4,3 \times 10^{-4}$ Kg m²

**DIMENSIONI
SIZE
ABMESSUNGEN**

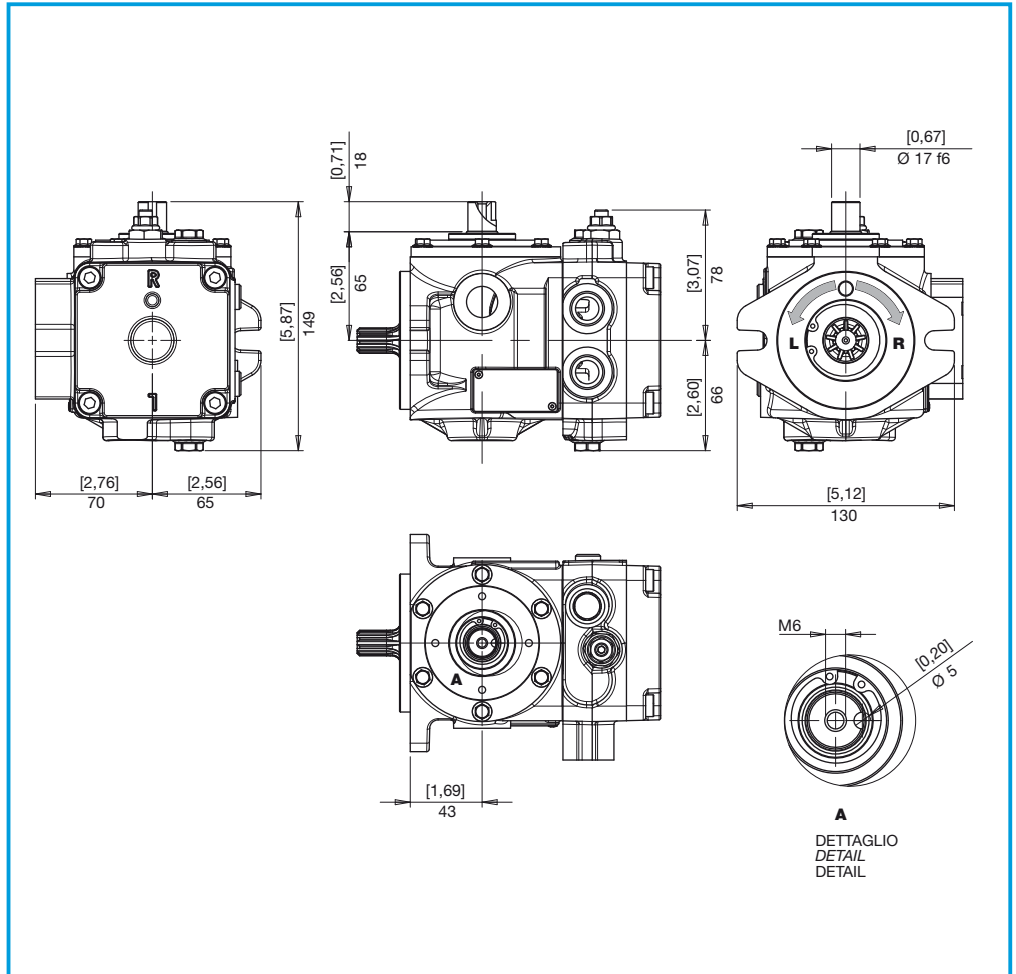

FLANGE
FLANGES
FLANSCH

HM POB

A SAE A
SAE A
SAE A

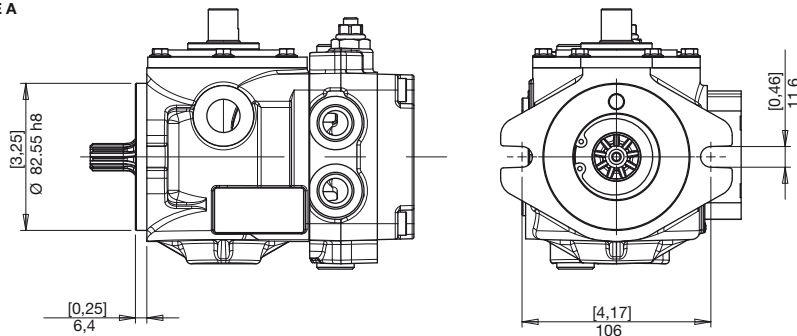

ESTREMITÀ ALBERI
SPLINE SHAFTS
WELLENPROFILE

J COPPIA MAX
MAX TORQUE
MAX DREHMOMENT 220 N•m

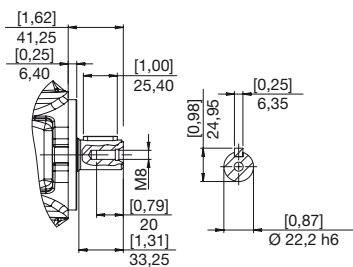

P COPPIA MAX
MAX TORQUE
MAX DREHMOMENT 80 N•m

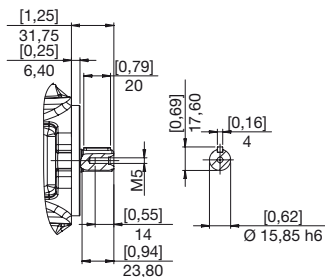

V COPPIA MAX
MAX TORQUE
MAX DREHMOMENT 120 N•m

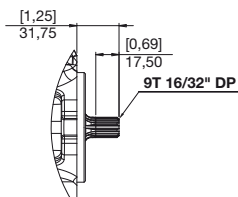

X COPPIA MAX
MAX TORQUE
MAX DREHMOMENT 170 N•m

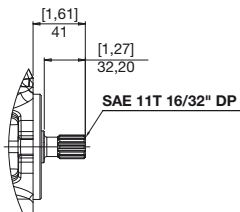

9 COPPIA MAX
MAX TORQUE
MAX DREHMOMENT 220 N•m

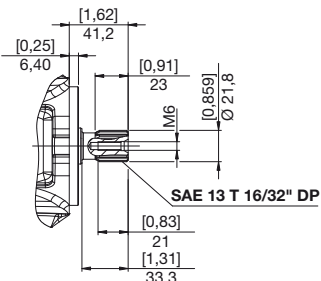



**BOCCHIE
PORTS
ANSCHLÜSSE**

HM POB

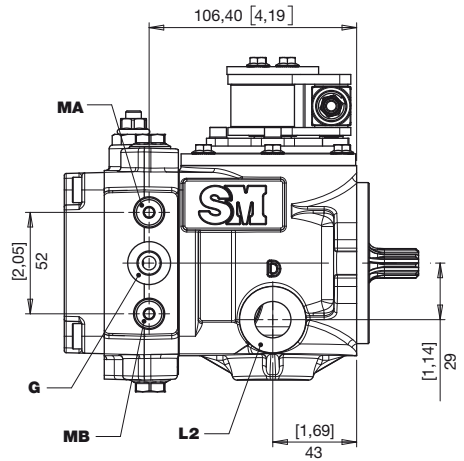
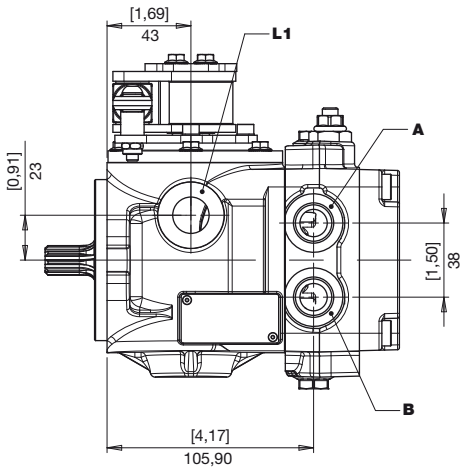
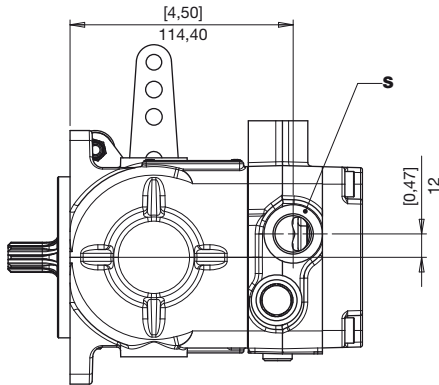

A	Utilizzi Use	G	Presse bassa pressione Test port boost pressure Messanschluß Speisedruck
B	Verbraucher	MA	Presse alta pressione Test port high pressure Messanschluß Hochdruck
L1	Drenaggi Drain	MB	
L2	Leckölanschluß		
S	Aspirazione Feeding pump inlet Ansaugöffnung		

**BOCCHIE
PORTS
ANSCHLÜSSE**

HM POB

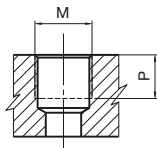

TIPO TYPE TYP		M		P	
		Nm	mm	mm	in
G1	1/8" GAS BSPP	8	8		0,31
G2	1/4" GAS BSPP	17	9		0,35
G4	1/2" GAS BSPP	70	14,5		0,57

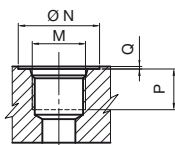

TIPO TYPE TYP	DIMENSIONE SIZE GRÖSSE	N		P		Q		M	
		mm	in	mm	in	mm	in		Nm
U2	1/4"	20	0,79	12	0,47	0,3	0,01	7/16-20 UNF	17
U5	5/8"	34	1,34	18	0,71	0,3	0,01	3/4-16 UNF	70

**COMBINAZIONI
COMBINATIONS
KOMBINATIONEN**

TIPO TYPE TYP	S ASPIRAZIONE INLET SAUGSEITE	A - B MANDATA OUTLET AUSGANG	L1 - L2 DRENAGGI DRAIN LECKÖLANSCHLUSS	PRESE PRESSIONE PRESSURE INTAKE DRUCKANSCHLÜSSE	
				MA-MB	G
G	G4	G4	G4	G1	G2
U	U5	U5	U5	G1	U2



**COMANDI
CONTROLS
STEUERUNGEN**

HM POB

L MANUALE SENZA AZZERATORE
MANUAL WITHOUT ZEROING
MANUELL OHNE NULLSTELLUNG

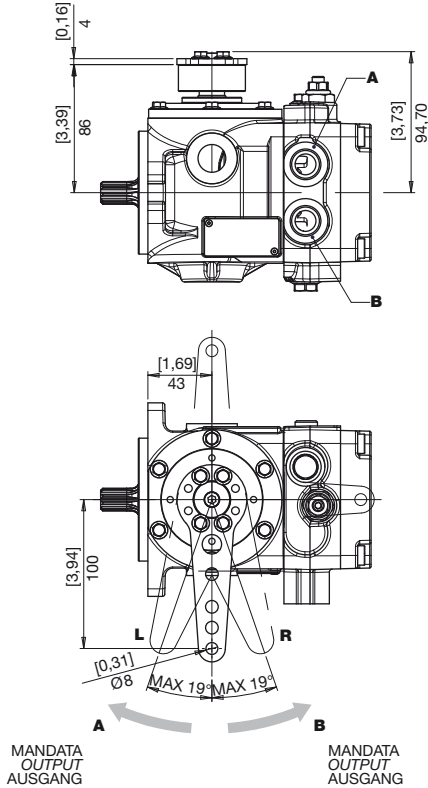

M MANUALE CON AZZERATORE
MANUAL WITH ZEROING
MANUELL MIT NULLSTELLUNG

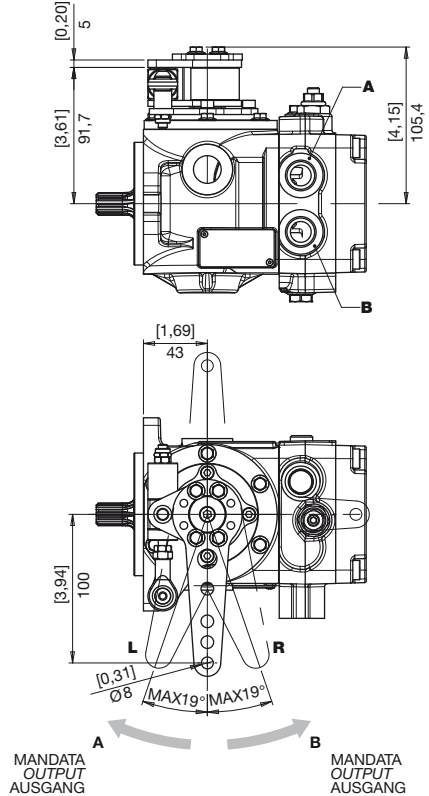

L M

ROTAZIONE DIRECTION DREHRICHTUNG	POSIZIONE LEVA LEVER POSITION HEBELSTELLUNG	MANDATA OUTPUT AUSGANG	ASPIRAZIONE SUCTION SAUGSEITE
DESTRA RIGHT RECHTS	R	A	B
	L	B	A
SINISTRA LEFT LINKS	R	B	A
	L	A	B

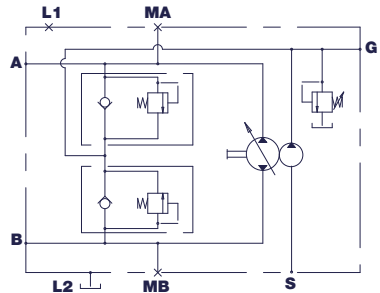

MOMENTI TORCENTI LEVA DI COMANDO
TORQUE FOR CONTROL PIN ACTUATION
DREHMOMENT FÜR SCHWENKWINKELVERSTELLUNG

HM POB

L MANUALE SENZA AZZERATORE
 MANUAL WITHOUT ZEROING
 MANUELL OHNE NULLSTELLUNG

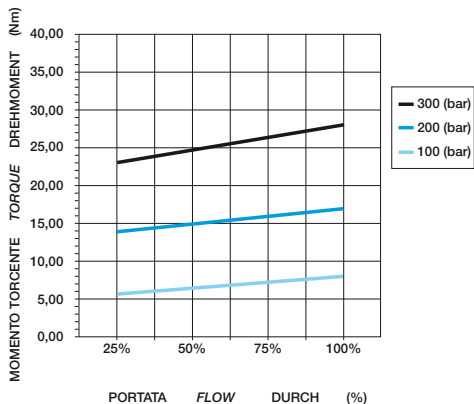

M MANUALE CON AZZERATORE
 MANUAL WITH ZEROING
 MANUELL MIT NULLSTELLUNG

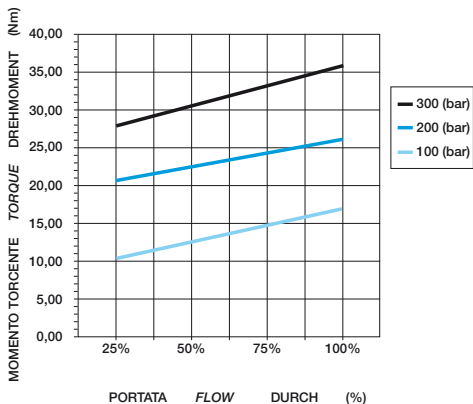



**PREDISPOSIZIONI
VERSION
BAUART**

HM POB

0 NESSUNA PREDISPOSIZIONE SENZA POMPA DI ALIMENTAZIONE
NO AUXILIARY MOUNT WITHOUT CHARGE PUMP
OHNE ANSCHLUSSFLANSCH OHNE SPEISEPUMPE

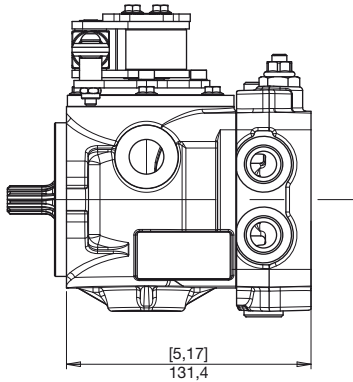

1 NESSUNA PREDISPOSIZIONE CON POMPA DI ALIMENTAZIONE
NO AUXILIARY MOUNT WITH CHARGE PUMP
OHNE ANSCHLUSSFLANSCH MIT SPEISEPUMPE

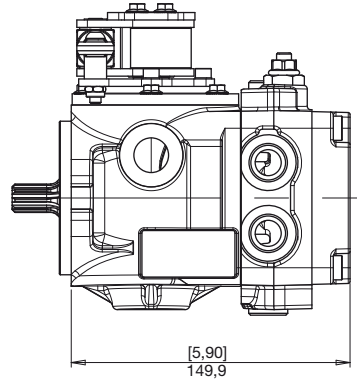

2 SAE A CON POMPA SOVRALIMENTAZIONE
SAE A WITH CHARGE PUMP
SAE A MIT SPEISEPUMPE

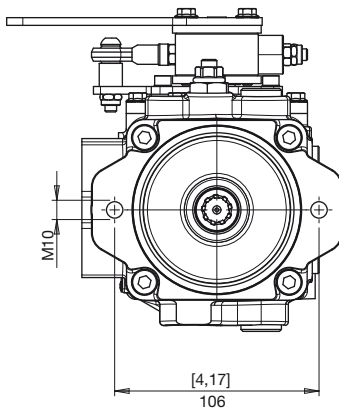

5 SAE A SENZA POMPA SOVRALIMENTAZIONE
SAE A WITHOUT CHARGE PUMP
SAE A OHNE SPEISEPUMPE

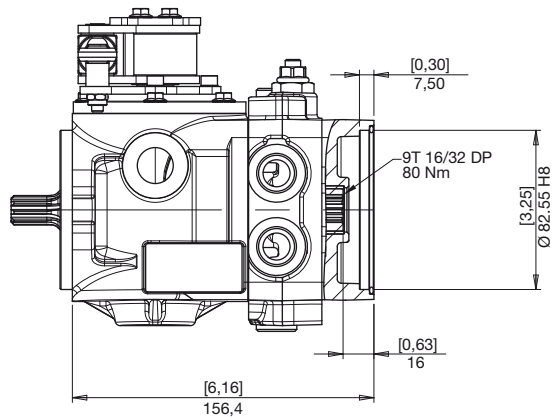

Su richiesta è possibile avere la flangia ruotata di 90°
On request it is possible to have the flange rotated by 90°
Auf Wunsch kann der Flansch eine um 90° gedrehte Stellung einnehmen.

4 POMPA INGRANAGGI TEDESCA Ø 52 CON POMPA SOVRALIMENTAZIONE
GEAR PUMP GERMAN Ø 52 WITH CHARGE PUMP
ZAHNRADPUMPE DIN-NORME Ø 52 MIT SPEISEPUMPE

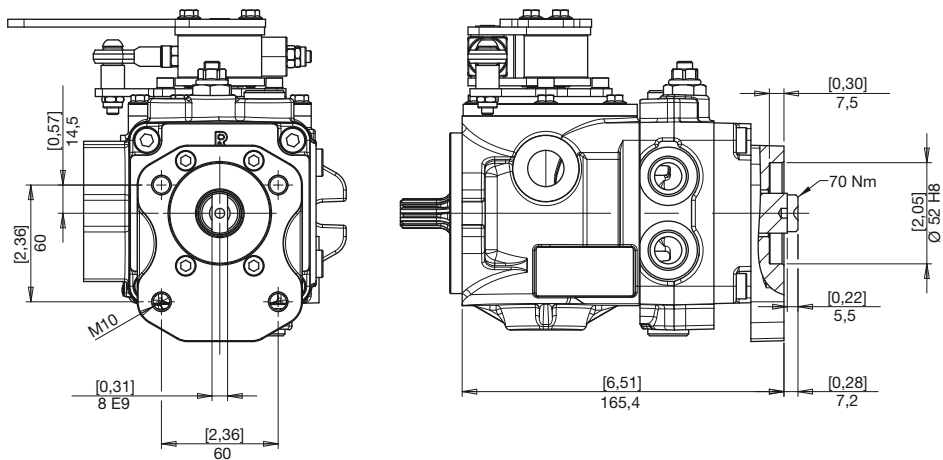

7 POMPA INGRANAGGI TEDESCA Ø 52 SENZA POMPA SOVRALIMENTAZIONE
GEAR PUMP GERMAN Ø 52 WITHOUT CHARGE PUMP
ZAHNRADPUMPE DIN-NORME Ø 52 OHNE SPEISEPUMPE

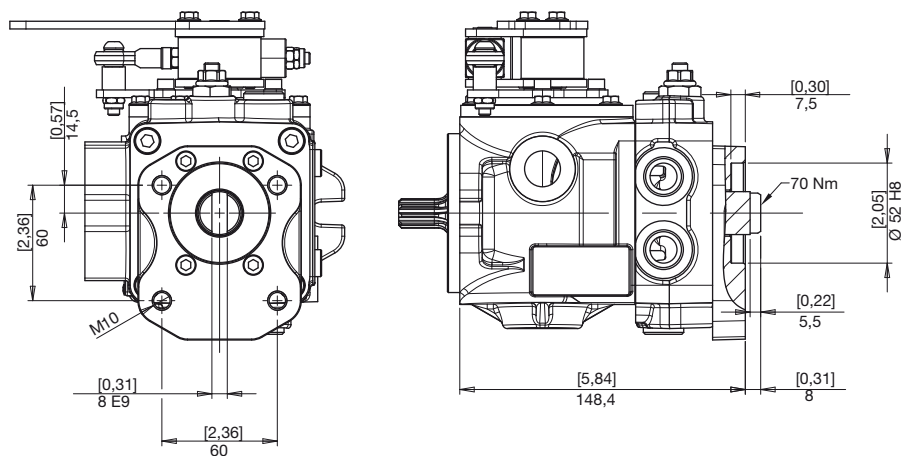



PREDISPOSIZIONI
VERSION
BAUART

HM POB

8 POMPA INGRANAGGI GR 1 CON POMPA SOVRALIMENTAZIONE
GEAR PUMP GR 1 WITH CHARGE PUMP
ZAHNRADPUMPE GR 1 MIT SPEISEPUMPE

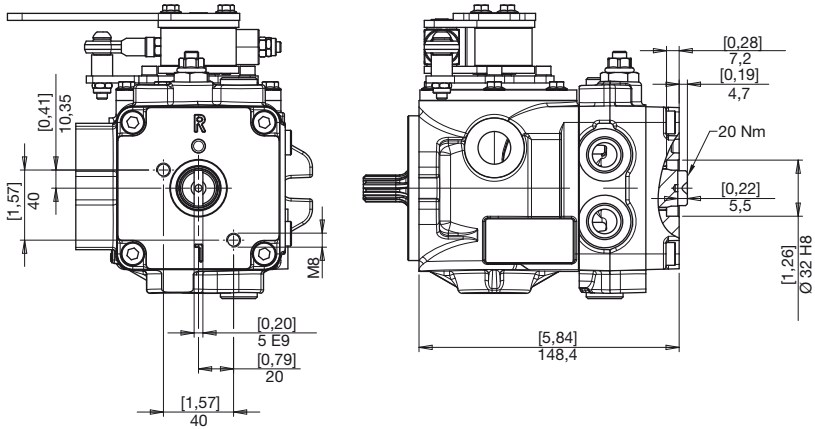

9 POMPA INGRANAGGI GR 1 SENZA POMPA SOVRALIMENTAZIONE
GEAR PUMP GR 1 WITHOUT CHARGE PUMP
ZAHNRADPUMPE GR 1 OHNE SPEISEPUMPE

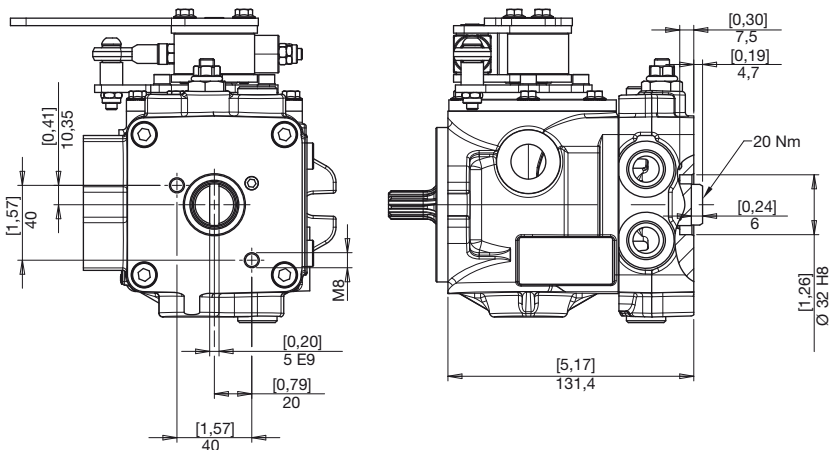

X FILTRO CON INDICATORE DI INTASAMENTO ELETTRICO
FILTER WITH ELECTRIC CLOGGING INDICATOR
FILTER MIT ELEKTRISHEM VERSTOPFUNGSANZEIGER

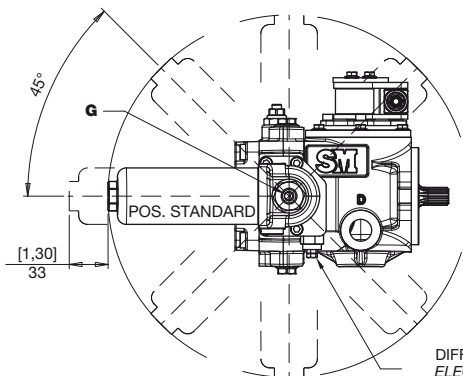

INDICATORE
DIFFERENZIALE ELETTRICO
ELECTRICAL DIFFERENTIAL
INDICATOR
DIFFERENZDRUCKANZEIGER
30VDC - 0,2 A max

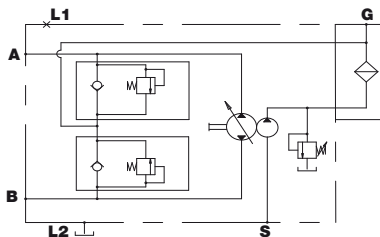
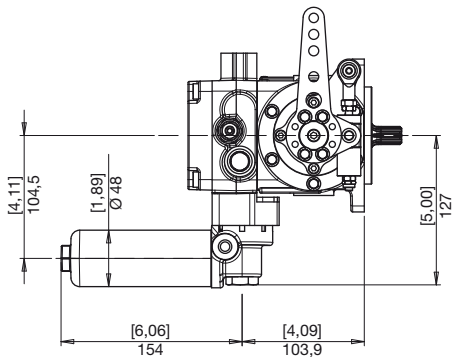

È possibile richiedere il filtro ruotato ad intervalli di 45°
You can ask the filter rotated at intervals of 45°
Sie können den Filter bei 45°-Schritten gedreht gelten

G	Preso olio filtrato Filtered oil intake Anschluss filtriertes Öl	G 1/4" BSPP
		7/16-20 UNF



Y **FILTRO SENZA INDICATORE DI INTASAMENTO
FILTER WITHOUT ELECTRIC CLOGGING INDICATOR
FILTER OHNE ELEKTRISCHEN VERSTOPFUNGSANZEIGER**

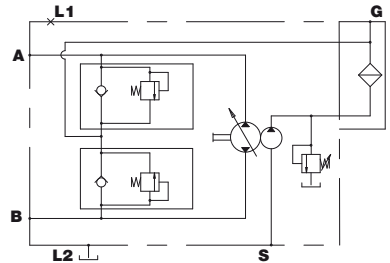
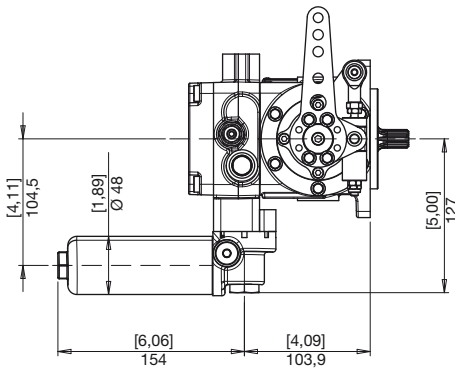
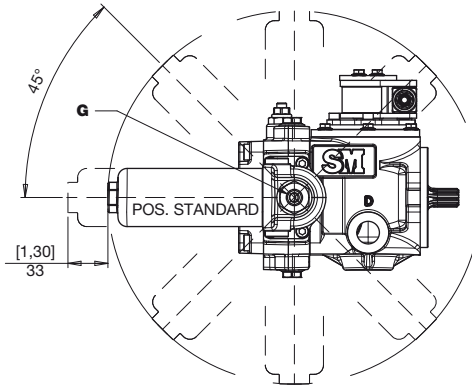

È possibile richiedere il filtro ruotato ad intervalli di 45°
You can ask the filter rotated at intervals of 45°
Sie können den Filter bei 45° -Schritten gedreht gelten

G	Preso olio filtrato <i>Filtered oil intake</i> Anschluss filteriertes Öl	G 1/4" BSPP
		7/16-20 UNF

B BY-PASS
BY-PASS
BY-PASS

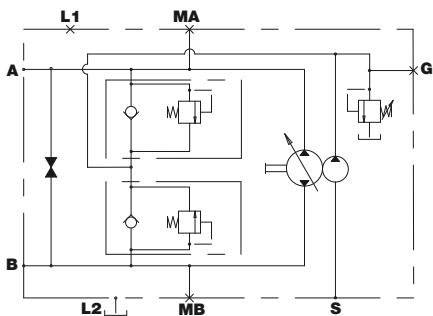
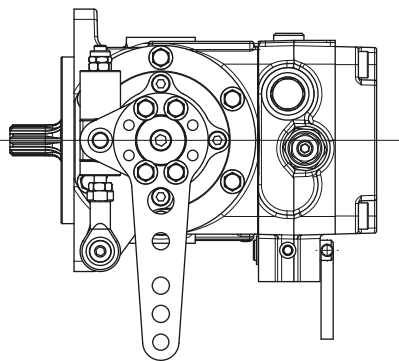
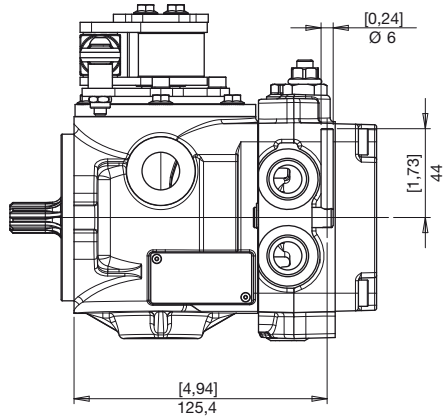
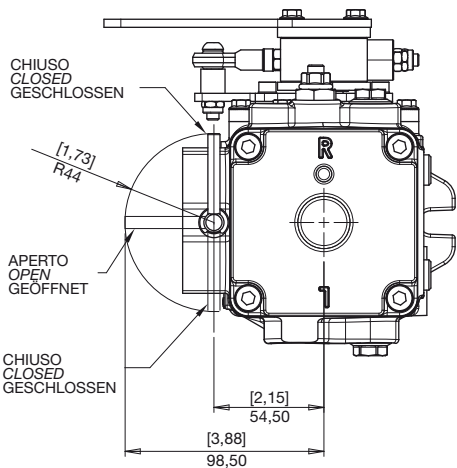



**ACCESSORI
ACCESSORIES
ZUBEHÖR**

HM POB



**VALVOLA DI FLUSSAGGIO
FLUSHING AND BOOST VALVE
SPUL- UND SPEISEDRIKVENTIL**

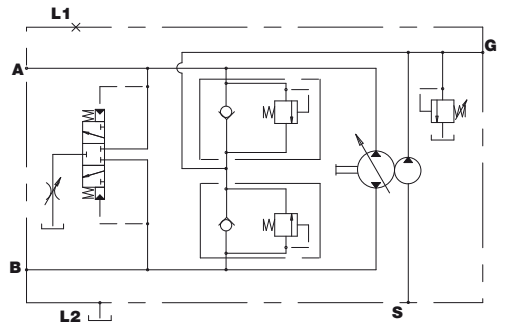
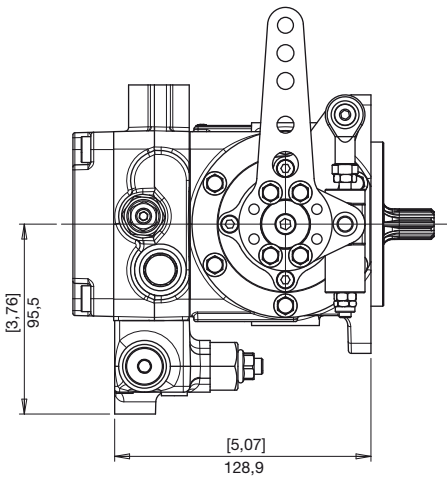
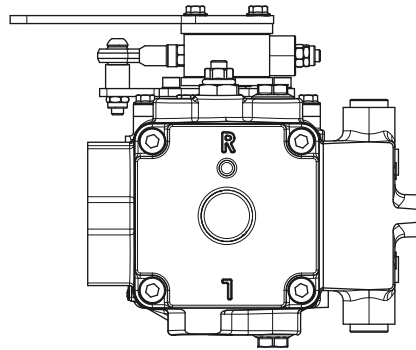
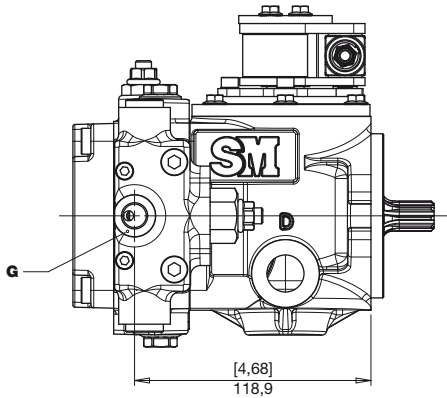

W VALVOLA BY-PASS + SBLOCCO FRENO
BY-PASS VALVE + BRAKE RELEASE
BY-PASS VENTIL + BREMSE LÖSEN

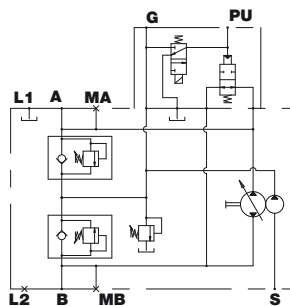
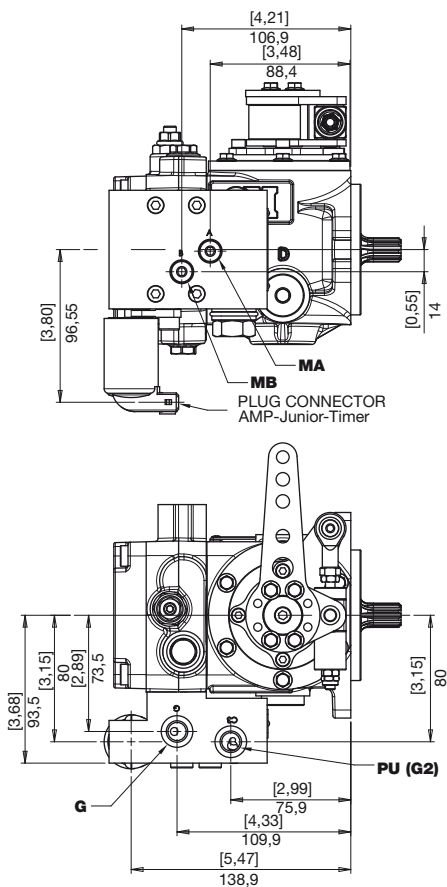

PU Pilotaggio sblocco freno (G2)
Brake opening pressure (G2)
Bremse öffnung druck (G2)



ISTRUZIONI PER L'ORDINAZIONE
ORDERING INSTRUCTIONS
BESTELLANLEITUNG

HM POB

HM PO B 07 R S J G L B A 1 0 ...

PRODOTTO
PRODUCT
PRODUKT

SERIE
SERIES
SERIE

CILINDRATA
DISPLACEMENT
FÖRDERVOLUMEN
07 = 7 cc 12 = 12 cc
08 = 8 cc 13 = 13 cc
09 = 9 cc 14 = 14 cc
10 = 10 cc 16 = 16 cc
11 = 11 cc 18 = 18 cc

SENSO DI ROTAZIONE
ROTATION
DREHRICHTUNG
R - Destra L - Sinistra
Right Left
Rechts Links

S - Pompa singola
Single pump
Einzelne Pumpe
T - Pompa ant. Tandem
Tandem front pump
Vordere Tandem-Pumpe
C - Pompa post. Tandem
Tandem rear pump
Hintere Tandem-Pumpe

ESTREMITÀ D'ALBERO
SHAFT PROFILE
WELLENENDE
J - Ø 22,22
P - Ø 15,85
V - 9T 16/32 DP
X - SAE 11T 16/32" DP
9 - SAE 13T 16/32" DP
Special for high torque
R - SAE 13T 16/32" DP
A - Rear pump shaft Z21

BOCCHIE
PORTS
ANSCHLÜSSE
G - Gas
U - UNF

COMANDO CONTROL STEUERUNG
L - Manuale senza azzeratore
M - Manuale con azzeratore (Molla Standard)
B - Manuale con azzeratore (Molla Soft)
A - Manuale con azzeratore (Molla Hard)
C - Manuale con azzeratore (Molla Extra Hard)
L - Manual without zeroing
M - Manual with zeroing (Standard spring)
B - Manual with zeroing (Soft spring)
A - Manual with zeroing (Hard spring)
C - Manual with zeroing (Extra Hard spring)
L - Manuell ohne Nullstellung
M - Manuell mit Nullstellung (Feder Standard)
B - Manuell mit Nullstellung (Feder Soft)
A - Manuell mit Nullstellung (Feder Hard)
C - Manuell mit Nullstellung (Feder Extra Hard)

TARATURA VALVOLE
VALVE SETTING
VENTILE

B - 150 bar G - 250 bar
D - 180 bar I - 280 bar
E - 210 bar L - 300 bar
H - 230 bar

ESECUZIONI SPECIALI
SPECIAL VERSIONS
SONDERBAUARTEN

ACCESSORI ACCESSORIES ZUBEHÖR

0 - nessuno
B - By-pass
M - Valvola di flusso taratura regolabile
U - Valvola di flusso taratura fissa
W - Valvola by-pass+ sblocco freno
X - filtro con indicatore di intasamento
Y - filtro senza indicatore di intasamento
0 - no accessories
B - By-pass
M - Flushing and boost valve adjustable setting
U - Flushing and boost valve fixed setting
W - By-pass valve+ brake release
X - filter with electric clogging indicator
Y - filter without electric clogging indicator
0 - Ohne Zubehör
B - By-pass
M - Spül- und speisedruckventil
U - Spül- und speisedruckventil
W - By-pass ventili + Bremse lösen
X - Filter mit Verstopfungsanzeiger
Y - Filter ohne Verstopfungsanzeiger

PREDISPOSIZIONI VERSION BAUART

0 - nessuna, senza pompa di alimentazione
1 - nessuna, con pompa di alimentazione 5cc
A - nessuna, con pompa di alimentazione 8cc
5 - SAE A, senza pompa di alimentazione
2 - SAE A, con pompa di alimentazione 5cc
B - SAE A, con pompa di alimentazione 8cc
7 - GR2 senza pompa di alimentazione
4 - GR2 con pompa di alimentazione 5cc
9 - GR1, senza pompa di alimentazione
8 - GR1, con pompa di alimentazione 5cc
N - predispo. tandem, senza pompa di alimentazione
Z - predispo. tandem, con pompa di alimentazione 5cc
P - predispo. tandem, con pompa di alimentazione 8cc

0 - No auxiliary mount without charge pump
1 - No auxiliary mount with charge pump 5cc
A - No auxiliary mount with charge pump 8cc
5 - SAE A mounting without charge pump
2 - SAE A mount with charge pump 5cc
B - SAE A mount with charge pump 8cc
7 - GR2 mount without charge pump
4 - GR2 mount with charge pump 5cc
9 - GR1 mount without charge pump
8 - GR1 mount with charge pump 5cc
N - Tandem pump mount without charge pump
Z - Tandem pump mount with charge pump 5cc
P - Tandem pump mount with charge pump 8cc
0 - Ohne Anschlussflansch, ohne Speisepumpe
1 - Ohne Anschlussflansch, mit Speisepumpe 5cc
A - Ohne Anschlussflansch, mit Speisepumpe 8cc
5 - SAE A-Anschlussflansch, ohne Speisepumpe
2 - SAE A -Anschlussflansch, mit Speisepumpe 5cc
B - SAE A -Anschlussflansch, mit Speisepumpe 8cc
7 - GR2-Anschlussflansch, ohne Speisepumpe
4 - GR2 -Anschlussflansch, mit Speisepumpe 5cc
9 - GR1 ohne Speisepumpe
8 - GR1 mit Speisepumpe 5cc
N - Vorbereitet für Tandempumpe, ohne Speisepumpe
Z - Vorbereitet für Tandempumpe, mit Speisepumpe 5cc
P - Vorbereitet für Tandempumpe, mit Speisepumpe 8cc

TIPO DI OSCILLANTE SWASHPLATE TYPE
SCHWENKSCHLEIBENLAGERUNG

A = oscillante su rullini
B = oscillante su bronzo
A = mounted on needle bearing
B = mounted on bronze bearings
A - Rollengelager
B - Bronze-Gleitlager

**POMPE MULTIPLE
MULTIPLE PUMPS
MEHRFACHPUMPEN**

**POMPA DOPPIA CON 1 POMPA DI SOVRALIMENTAZIONE
DOUBLE PUMP WITH 1 BOOST PUMP
TANDEMPUMPE MIT 1 SPEISEPUMPE**

Il codice di ordinazione di una pompa multipla si ottiene sommando, come mostrato in esempio, i codici delle singole pompe (stadi) ricavati seguendo le regole di ordinazione delle pompe singole.

You build the ordering code of a multiple pump by summing the order code of the individual pumps, see our example.

Der Bestellschlüssel einer Mehrfachpumpe ergibt sich durch Summieren der Einzel-Bestellschlüssel, siehe Beispiel

1° STADIO STAGE STUFE													2° STADIO STAGE STUFE												
HM	PO	B	08	R	T	V	G	M	E	B	P	0	HM	PO	B	08	R	C	V	G	M	E	B	0	0
HM	PO	B	08	R	T	R	G	M	E	B	N	0	HM	PO	B	08	R	C	A	G	M	E	B	A	0

With reinforced shaft 200 Nm

1° STADIO STAGE STUFE													2° STADIO STAGE STUFE												
HM	PO	B	08	R	T	V	G	M	E	B	P	0	HM	PO	B	08	R	C	V	G	M	E	B	5	0
HM	PO	B	08	R	R	V	G	M	E	B	N	0	HM	PO	B	08	R	C	A	G	M	E	B	B	0

With reinforced shaft 200 Nm

Nelle pompe tandem con una pompa di sovralimentazione è obbligatorio installare nell'impianto un tubo di collegamento (non fornito) tra un drenaggio del primo stadio ed un drenaggio del secondo stadio.

In the tandem pumps with one boost pump it is mandatory to assemble in the plant a connecting pipe (not supplied) between a drain of the first stage and a drain of the second one.

Bei den Tandempumpen mit einer Verstärkerpumpe muss in der Anlage ein Verbindungsrohr (nicht beige stellt) zwischen einer Drainage der ersten Stufe und einer Drainage der zweiten Stufe installiert werden.

- La configurazione Tandem standard è con pompa da 8cc nel primo stadio.
- Con albero rinforzato è disponibile una sola configurazione con pompa da 8cc nel secondo stadio.

- The standard Tandem configuration is with a 8cm³ pump in the first stage.
- With reinforced shaft only one configuration with 8cm³ pump in the second stage is available.

- Die serienmäßige Tandemversion hat eine 8cc Pumpe in der ersten Stufe.
- Mit verstärkter Welle ist nur eine einzige Ausführung mit 8cc in der zweiten Stufe erhältlich.



1° STADIO STAGE STUFE

2° STADIO STAGE STUFE

HM PO A 08 R T V G M E B P O HM PO A 08 R C V G M E B 9 O

GR1

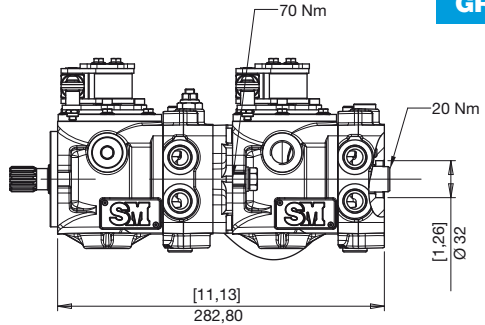
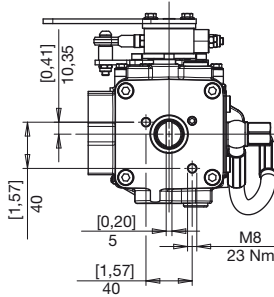

1° STADIO STAGE STUFE

2° STADIO STAGE STUFE

HM PO A 08 R T V G M E B P O HM PO A 08 R C V G M E B 7 O

GR2

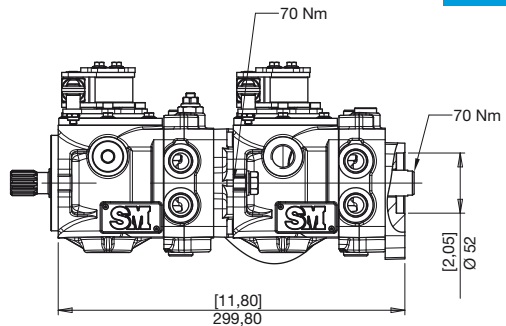
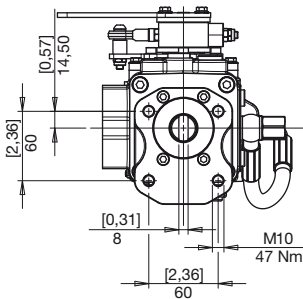

Nelle pompe tandem con una pompa di sovrimentazione è obbligatorio installare nell'impianto un tubo di collegamento (non fornito) tra un drenaggio del primo stadio ed un drenaggio del secondo stadio.

In the tandem pumps with one boost pump it is mandatory to assemble in the plant a connecting pipe (not supplied) between a drain of the first stage and a drain of the second one.

Bei den Tandempumpen mit einer Verstärkerpumpe muss in der Anlage ein Verbindungsrohr (nicht beigelegt) zwischen einer Drainage der ersten Stufe und einer Drainage der zweiten Stufe installiert werden.