



**POMPE E MOTORI A PISTONI ASSIALI
AD ASSE INCLINATO**

***BENT AXIS AXIAL PISTON
PUMPS AND MOTORS***

AXIALKOLBENPUMPEN-MOTOREN

**HM PF
10.12.16**



GS Global Resources • 1-800-261-8735 • gsglobalresources.com
926 Perkins Drive, Mukwonago, WI 53149

© GS GLOBAL RESOURCES, INC. ALL RIGHTS RESERVED.

398SBF0013A01

HM PF

POMPE A PISTONI ASSIALI PER CIRCUITO APERTO A CILINDRATA FISSA OPEN CIRCUIT AXIAL FIXED-DISPLACEMENT PISTON PUMPS AXIALKOLBENPUMPEN FÜR DEN OFFENEN KREISLAUF

Le pompe a pistoni assiali serie HM PF sono a cilindrata fissa del tipo ad asse inclinato e sono stati concepiti per operare in circuito aperto.

Il sistema è stato progettato in modo da ottenere un angolo di inclinazione di 40° dei pompanti rispetto all'asse dell'albero uscente.

Tale geometria permette:

- elevata coppia di spunto
- elevata efficienza volumetrica e meccanica
- elevate pressioni massime

Axial piston pumps series HM PF are fixed displacement and bent axis and have been designed to work both in an open circuit.

The system has been designed in order to obtain 40° angle of inclination of the pumps with respect to the axle of the outgoing shaft.

This geometry allows:

- high static torque
- high volumetric and mechanical efficiency
- high maximum pressures

Die Axialkolbenpumpen der Baureihe HM PF sind Schrägscheibenmotoren mit konstantem Verdrängungsvolumen und können sowohl im offenen Kreislauf arbeiten.

Die Schrägachsenmotoren wurden so konstruiert, daß sie einen großen Schwenkwinkel von 40° haben.

Dies ermöglicht:

- Höheres Anlaufmoment
- Gute mechanisch hydraulische und volumetrische Wirkungsgrade
- Hohe Enddrehzahl
- Hohe Betriebsdrücke

HM PF 10.12.16

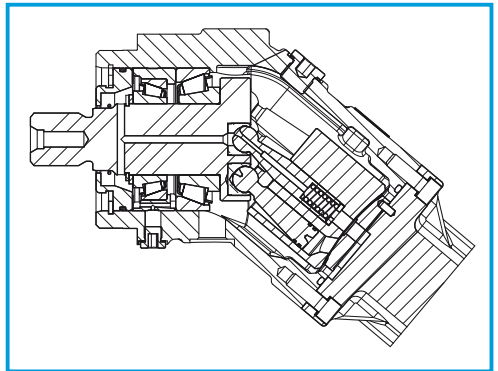
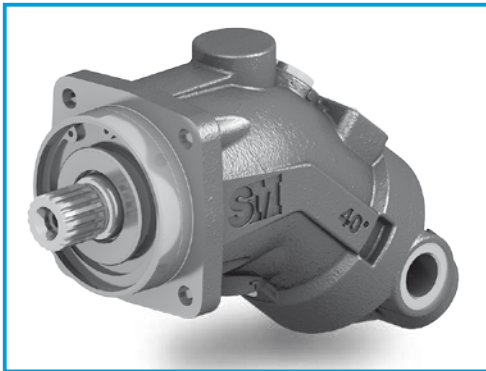

DATI TECNICI TECHNICAL DATA TECHNISCHE MERKMALE

GRUPPO GROUP BAUREIHE	CILINDRATA TEORICA NOMINAL DISPLACEMENT FÖRDERVOLUMEN		PRESSIONE PRESSURE DRUCK		VELOCITÀ DI ROTAZIONE SPEED DREHZAHL		COPPIA TORQUE DREHMOMENT		MASSA WEIGHT GEWICHT		MOMENTO POLARE D'INERZIA INERTIAL MASS TRAGHEITSMOMENT		
	cm ³	in ³	CONTINUA CONTINUOUS DAUER	INTERMITTENTE INTERMITTENT INTERMITTENDER	PICCO PEAK SPITZEN	n _{max} min ⁻¹	at 350 bar		kg	lbs	kg • m ²		
HM PF	10	0,61	350	5075	400	5800	450	6525	3000	57	6,6	14,5	0,0004
	12	0,732	350	5075	400	5800	450	6525	3000	67	6,6	14,5	0,0004
	16	0,976	350	5075	400	5800	450	6525	3000	88	6,6	14,5	0,0004

La velocità massima ammissibile può essere incrementata aumentando la pressione in alimentazione (vedi grafico).

By increase of the input pressure the max speed can be increased (see diagram).

Die zulässige Höchstgeschwindigkeit kann gesteigert werden, indem der Versorgungsdruck erhöht wird (siehe graphische Abbildung).

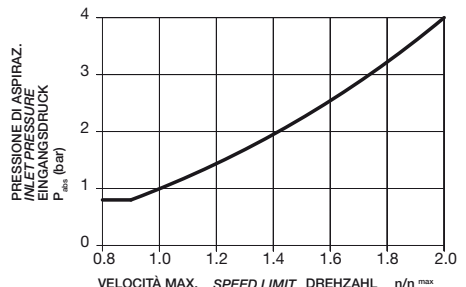



DIMENSIONI
SIZE
ABMESSUNGEN

HM PF

I FLANGIA ISO
ISO FLANGE
ISO FLANSCH

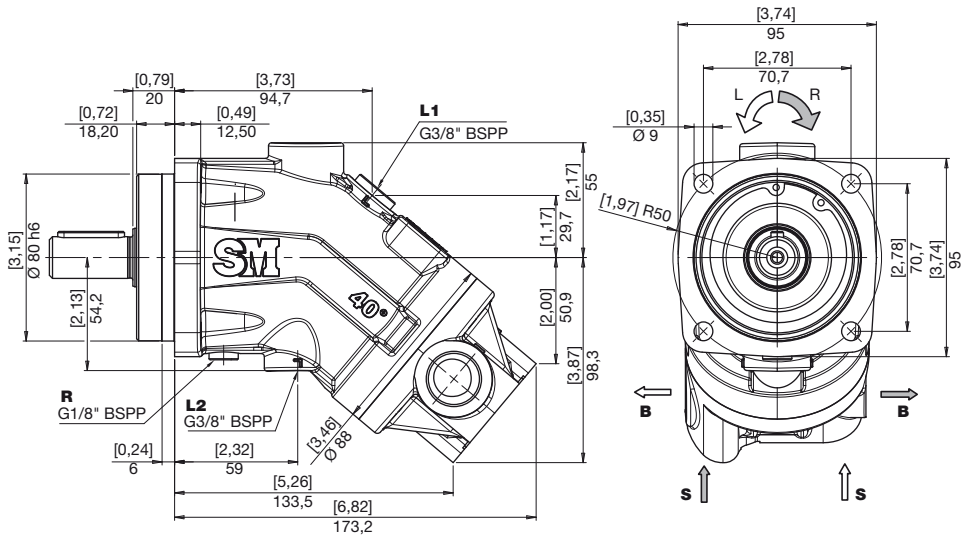

L1	Drenaggi Drain	R	Spurgo Air bleed Entlüftung
L2	Leckölanschluss		
S	Aspirazione Feeding pump inlet Ansaugöffnung	B	Mandata Outlet Ausgang
L1	Tappati Plugged		
R	Verschlossen		

Z COPPIA MAX
MAX TORQUE
MAX DREHMOMENT 350 N•m

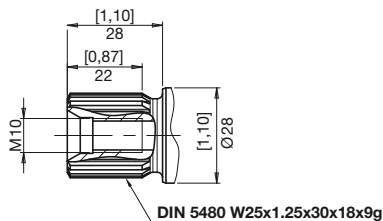

PRESSIONE CONTINUA
CONTINUOUS PRESSURE
NENNDRUCK

400 bar / 5800 psi

PRESSIONE DI PICCO
PEAK PRESSURE
HOCHSTDRUCK

450 bar / 6525 psi

X COPPIA MAX
MAX TORQUE
MAX DREHMOMENT 215 N•m

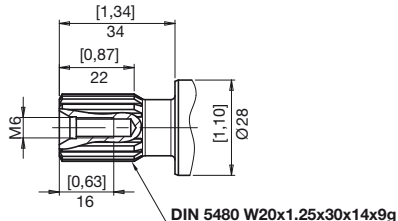

PRESSIONE CONTINUA
CONTINUOUS PRESSURE
NENNDRUCK

400 bar / 5800 psi

PRESSIONE DI PICCO
PEAK PRESSURE
HOCHSTDRUCK

450 bar / 6525 psi

C COPPIA MAX
MAX TORQUE
MAX DREHMOMENT 125 N•m

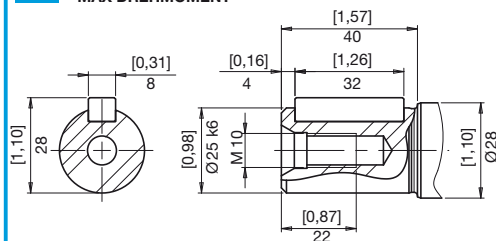

PRESSIONE CONTINUA
CONTINUOUS PRESSURE
NENNDRUCK

350 bar / 5075 psi

PRESSIONE DI PICCO
PEAK PRESSURE
HOCHSTDRUCK

400 bar / 5800 psi

Y COPPIA MAX
MAX TORQUE
MAX DREHMOMENT 85 N•m

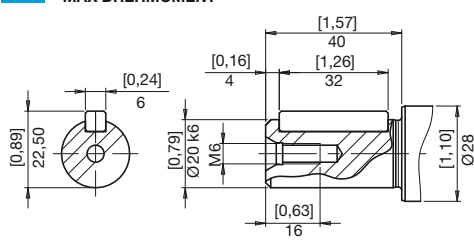

PRESSIONE CONTINUA
CONTINUOUS PRESSURE
NENNDRUCK

350 bar / 5075 psi

PRESSIONE DI PICCO
PEAK PRESSURE
HOCHSTDRUCK

400 bar / 5800 psi

Per applicazioni con carico radiale sull'albero motore (pignoni, cinghie trapezoidali), con albero tipo X e Y è consentita una pressione continua di 315 bar (Pmax = 350 bar). In caso di carico pulsante sopra 315 bar, utilizzare la versione con albero scanalato Z.

With shaft type X and Y is allowed a continuous pressure of 315 bar (Pmax = 350 bar) for applications with radial load of the drive shaft (pinions, belts). In cases of pulsating loading above 315 bar must be use the version with splined shaft Z.

Bei Wellenende X und Y ist bei Abtrieben mit Querkraftbelastung der Triebwelle (Ritzel, Keilriemen) ein Nenndruck von 315 bar zulässig (pmax = 350 bar). Bei pulsierender Belastung über 315 bar empfehlen wir die Ausführung mit Zahnwelle Z.



**DISTRIBUTORI
PORT PLATES
ANSCHLUSSPLATTE**

HM PF

FS

**ATTACCHI FILETTATI GAS
THREADED PORTS GAS
GEWINDEANSCHLUSSE GAS**

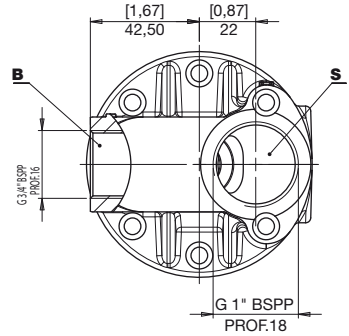
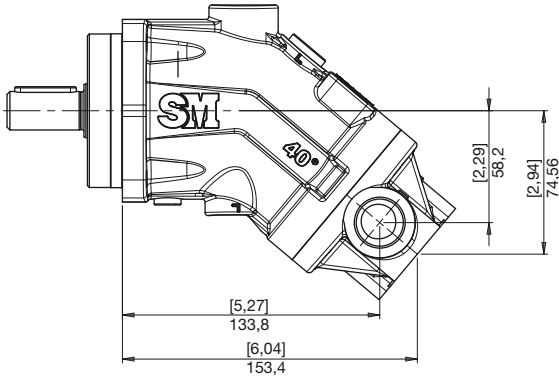

Nella versione sinistra il distributore è ruotato 180°.

In left version the port plate is 180° rotated.

In der linken Version ist der Verteiler um 180° gedreht.

