

Gear Pump – High Performance Version

GP1

Displacement up to 11,8 cm³ (0.72 inch³) • p_{max} 310 bar (4500 PSI) • Speed from 500 to 5000 RPM

Technical Features



- › Operating pressure 280 bar, Peak pressure 310 bar
- › High-strength quality aluminum alloys pump with axial play compensation
- › Low noise level in whole operating range
- › High operational reliability and service life for 3000 operation hours
- › High volumetric efficiency up to 98%
- › International standard flanges acc.to SAE, ISO, DIN, GOST

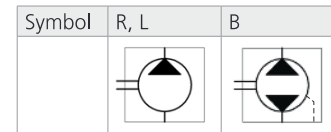

Technical Data

Nominal Size Parameters	Symbol	Unit	Displacement																
			0,8	1,2	1,6	2,1	2,5	3,3	3,6	4,4	4,8	5,8	6,2	7,0	7,9	10,0	11,8		
Actual displacement	V_g	[cm ³]	0,855	1,257	1,686	2,086	2,514	3,316	3,611	4,386	4,787	5,804	6,205	7,007	7,890	10,003	11,795		
		[in ³]	0.052	0.077	0.103	0.127	0.153	0.202	0.220	0.268	0.292	0.354	0.379	0.428	0.481	0.610	0.720		
Rotation speed	nominal	n_n	1500																
	minimum	n_{min}	800				600				500								
	maximum	n_{max}	5000				4500				4000		3800		3500		3000		1800
Pressure at inlet*	minimum	p_{1min}	-0,3 (-4.4 PSI)																
	maximum	p_{1max}	0,5 (7.3 PSI)																
Pressure at outlet**	max. continuous	p_{2n}	280				260		250	230	200	180	170	160	100				
		[PSI]	4061				3771		3625	3336	2901	2611	2466	2321	1450				
	maximum	p_{2max}	300				280		270	250	220	200	190	180	150				
		[PSI]	4351				4061		3916	3625	3191	2901	2756	2611	2176				
	peak	p_3	310				290		280	260	230	210	200	190	160				
		[PSI]	4496				4206		4061	3771	3336	3046	2901	2756	2321				
Nominal flow rate (min.) at n_n and p_{2n}	Q_n	[l·min ⁻¹]	1,07	1,60	2,13	2,71	3,35	4,54	4,98	6,06	6,61	8,00	8,56	9,65	10,90	13,90	16,30		
		[GPM]	0.28	0.42	0.56	0.72	0.88	1.20	1.32	1.60	1.75	2.11	2.26	2.55	2.88	3.67	4.31		
Maximum flow rate at n_{max} and p_{2max}	Q_{max}	[l·min ⁻¹]	3,92	5,88	7,06	9,26	9,80	12,94	14,11	17,25	17,88	21,60	21,27	20,58	23,23	17,64	20,82		
		[GPM]	1.04	1.55	1.87	2.45	2.59	3.42	3.73	4.56	4.72	5.71	5.62	5.44	6.14	4.66	5.50		
Nominal input power (max.) at n_n and p_{2n}	P_n	[kW]	0,7	1,04	1,39	1,72	2,07	2,97	3,35	3,23	3,24	3,41	3,29	3,50	3,71	2,94	3,47		
		[kW]	2,51	3,70	4,96	5,52	6,65	7,80	7,93	9,29	8,29	9,51	8,52	7,83	8,35	5,30	6,06		
Weight	m	[kg]	0,82	0,84	0,85	0,87	0,89	0,92	0,93	0,96	0,98	1,02	1,04	1,08	1,10	1,20	1,25		
		[lbs]	1.81	1.85	1.87	1.92	1.96	2.03	2.05	2.12	2.16	2.25	2.29	2.38	2.43	2.65	2.76		

- 1) *Inlet pressure in the reversible design can be up to $p_1 = p_{2n} - 70$ bar max. External drainage must be used in case of the reversible design.
- 2) **Outlet pressure in the reversible design is 10% lower than shown in the table (depending on operating conditions).
- 3) p_{2n} maximum continuous pressure - maximum working pressure, at which the pump can be operated without time limitation.
- 4) p_{2max} maximum pressure - maximum pressure permissible for a short time, max. 20 s.
- 5) p_3 peak pressure - short-time pressure (fractions of a second) arising in case of a sudden change of the operating mode; any excess of this pressure during operation is impermissible.

Gear Pump / Size		GP1 - 0,8 ... 11,8 ccm
Volumetric efficiency	%	92 ÷ 98
Mechanical efficiency	%	85
Fluid temperature range (NBR)	°C (°F)	-20...80 (-4...176)
Fluid temperature range (FPM)	°C (°F)	-20...120 (-4...248)
Viscosity range	mm ² /s (SUS)	20 ... 80 (97 ... 390), 1200 (5849) for cold start
Hydraulic fluid		Hydraulic oils of power classes (HL, HLP) to DIN 51524
Max. degree of fluid contamination for $p_2 \leq 200$ bar		Class 21/18/15 acc. to ISO 4406
Max. degree of fluid contamination for $p_2 \geq 200$ bar		Class 20/17/14 acc. to ISO 4406

0,8 ccm

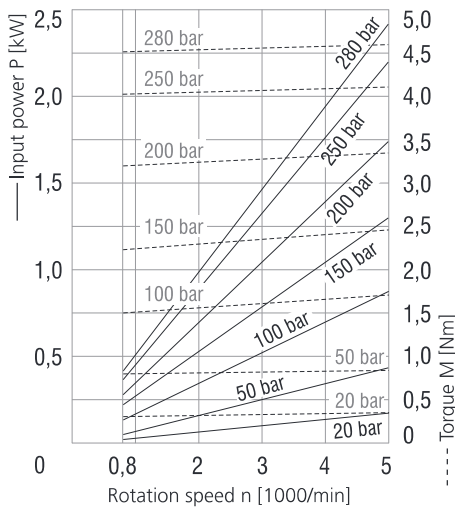

1,6 ccm

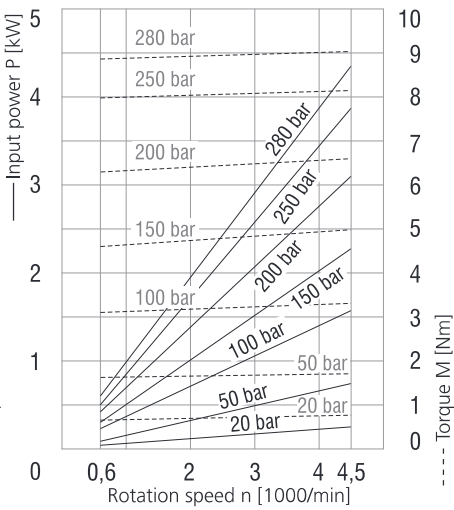

2,5 ccm

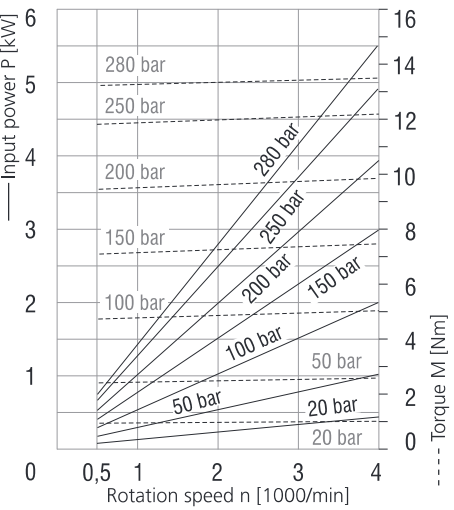

3,6 ccm

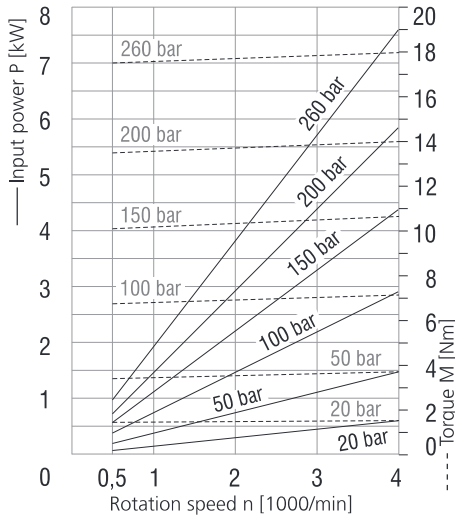

4,8 ccm

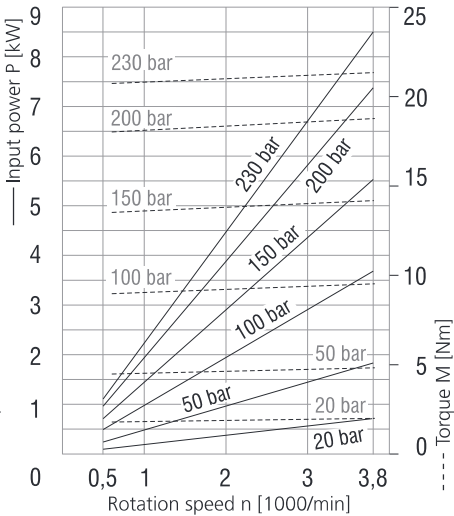

6,2 ccm

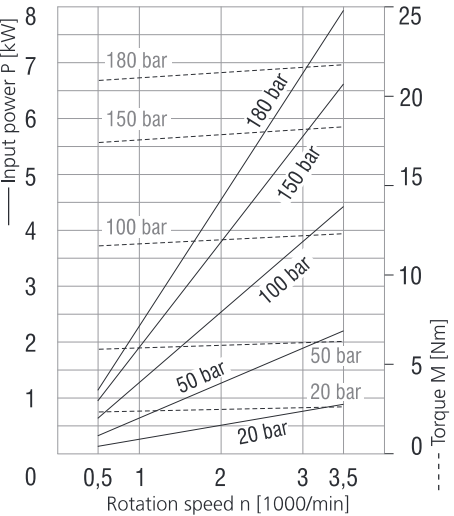

7,9 ccm

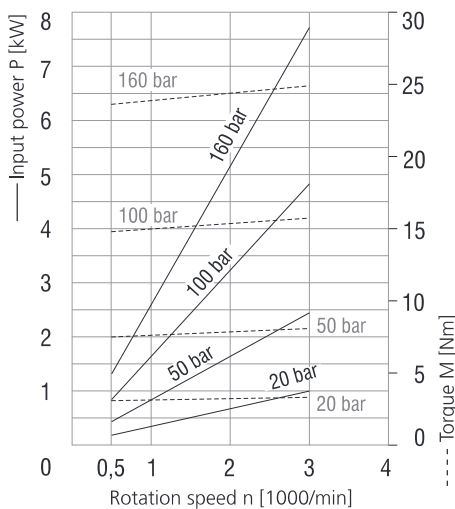

11,8 ccm

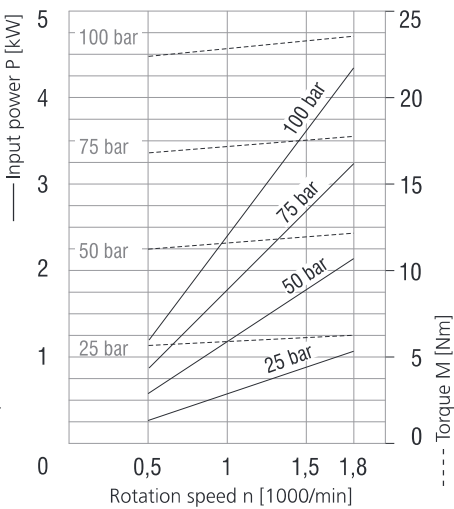

Ordering Code - Multiple Version

GP1	- 3,3 / 3,3	R	- SA	DA	- S	GBGB / GBGB	- V	004	
Gear pump serie 1	Front pump (shaft side) Rear pump					Front pump (shaft side) - inlet, outlet port Rear pump - inlet, outlet port.		No designation 004	Shaft seal standard without shaft seal
Displacement									Seals NBR PM (Viton)
Direction of rotation									Inlet / Outlet ports
Counter clockwise									
Clockwise									
Bi-directional									Ports orientation Use blind plug for not used suction ports
Flange design									Shaft Type *G Customized
*G Customized									

Ports orientation

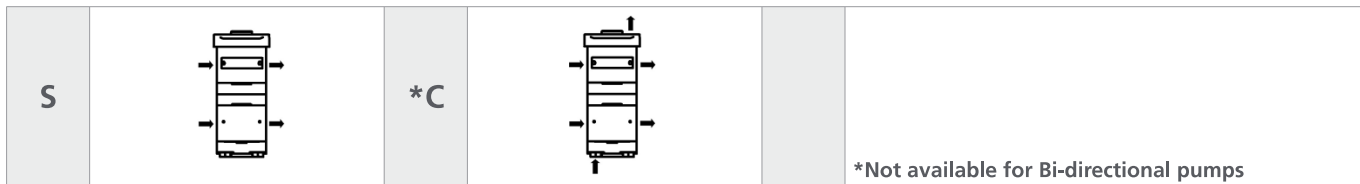

Flange design in millimeters (inches)

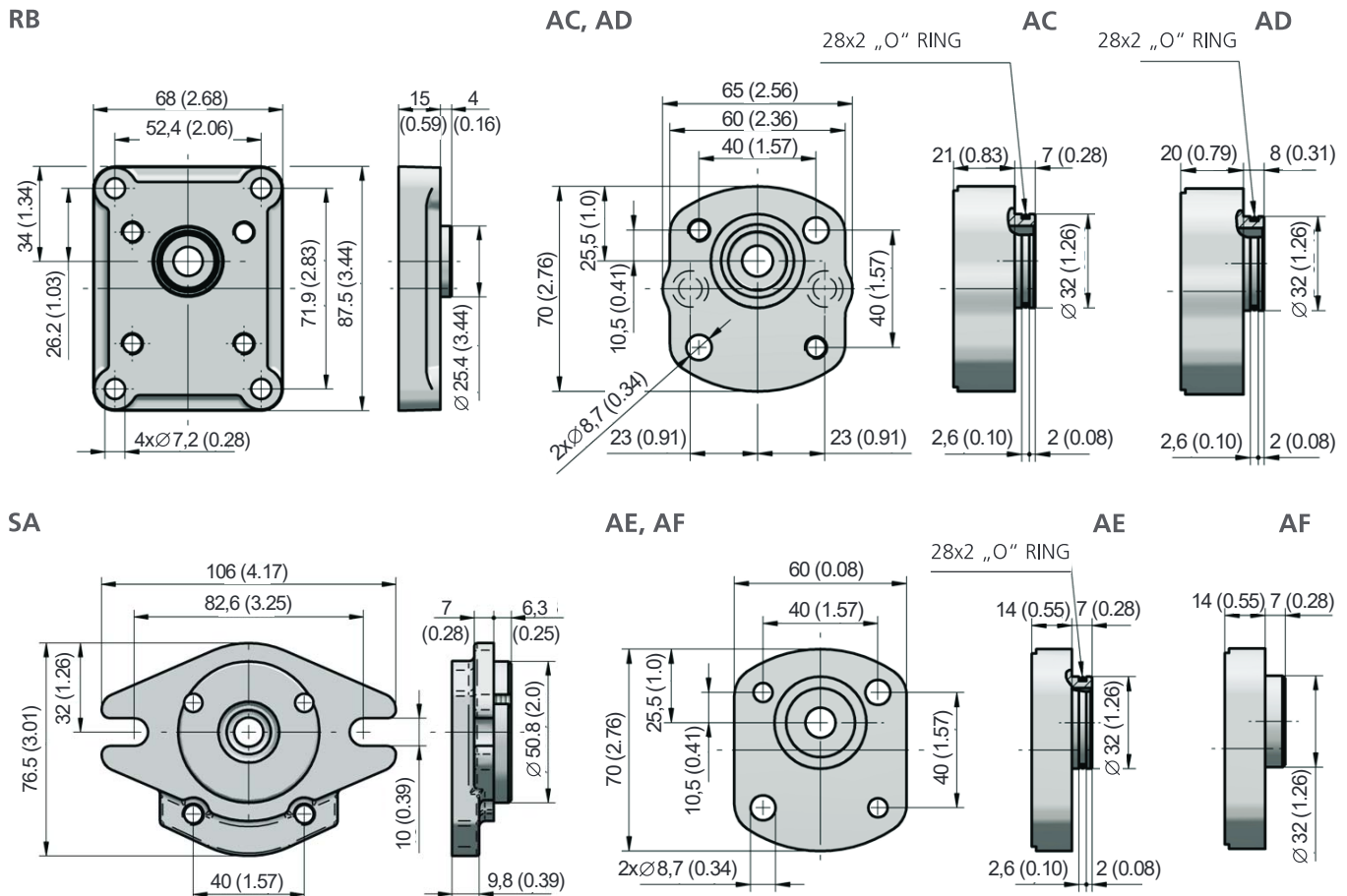

Shaft design in millimeters (inches)

VB

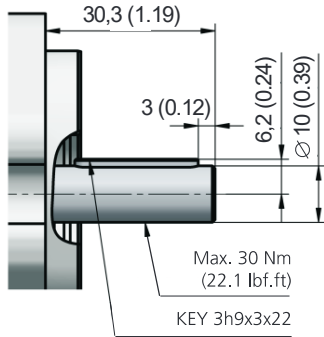

VC

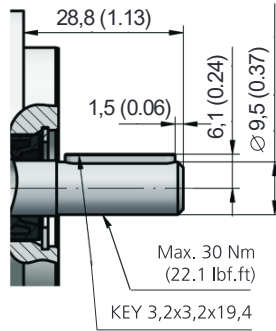

DA

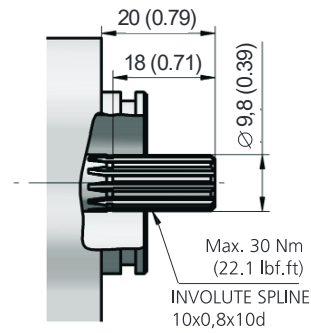

CB, CC

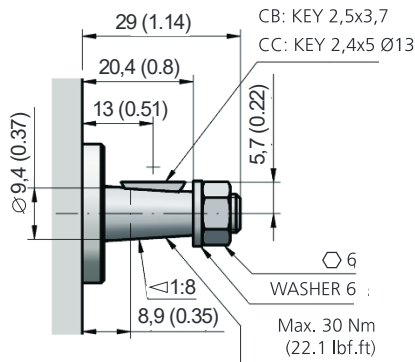

KC

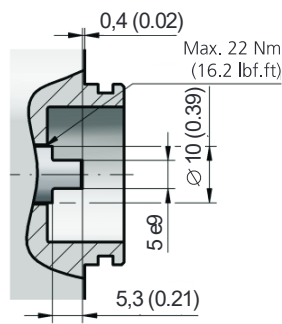

KD

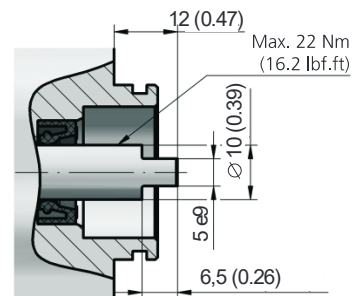

Ports design in millimeters (inches)

Metric thread according to ISO 6149

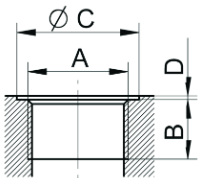

Displacement [cm ³ (in ³)]	Inlet Code	Dimension				Outlet Code	Displacement [cm ³ (in ³)]
		A	B	C	D		
	xx	M12x1,5	12 (0.47)	20 (0.79)	1 (0.04)	MB	ALL
0,18-0,5 (0.01-0.03)	MC	M14x1,5	13 (0.51)	26 (1.02)		MC	ALL
ALL	MD	M16x1,5	14 (0.55)	22 (0.89)		MD	ALL
ALL	ME	M18x1,5	13 (0.51)	30 (1.18)		ME	ALL
ALL	MF	M20x1,5	14 (0.55)	26 (1.02)		xx	
3,3-11,8 (0.20-0.72)	MH	M22x1,5	13 (0.51)	35 (1.38)		xx	
DRAIN	MA	M10x1	8 (0.31)	15 (0.59)		xx	

Ports design in millimeters (inches)

BSPP pipe thread according to 228-1

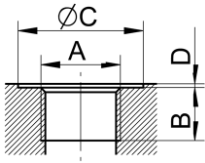

Displacement [cm ³ (in ³)]	Inlet Code	Dimension				Outlet Code
		A	B	C	D	
ALL	xx	G1/4	13 (0.51)	26 (1.02)	1 (0.04)	GA
	GB	G3/8		24 (0.94)		GB
	GC	G1/2		34 (1.34)		GC

UNF thread according to SAE

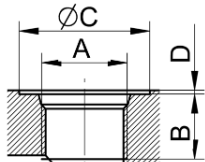

Displacement [cm ³ (in ³)]	Inlet Code	Dimension				Outlet Code
		A	B	C	D	
ALL	xx	9/16-18UNF	13 (0.51)	24,6 (0.97)	1 (0.04)	UB
	UC	3/4-16UNF				UC
	UD	7/8-14UNF	16 (0.63)	34 (1.34)		xx

Flanged fittings according to DIN 8901/8902

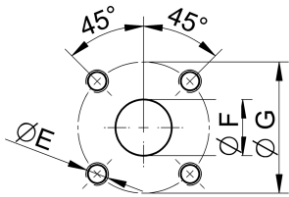

Displacement [cm ³ (in ³)]	Inlet Code	Dimension			Outlet Code
		E	F	G	
ALL	HA	M5, depth 12	8 (0.31)	26 (1.02)	HA
	HB		10 (0.39)		HB
	HC	M6 depth 12	8 (0.31)	30 (1.18)	HC
	HD		12 (0.47)		HD

Inlet / Outlet in flange

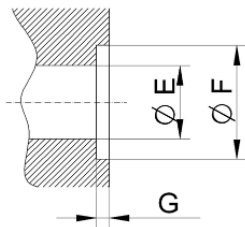

Code	Dimension		
	E	F	G
PA	8 (0.31)	12,4 (0.49)	1,4 (0.06)

GP1 Pumps - basic design in millimeters (inches)

GP1-*R(L)-SAVC-SUDUD-N

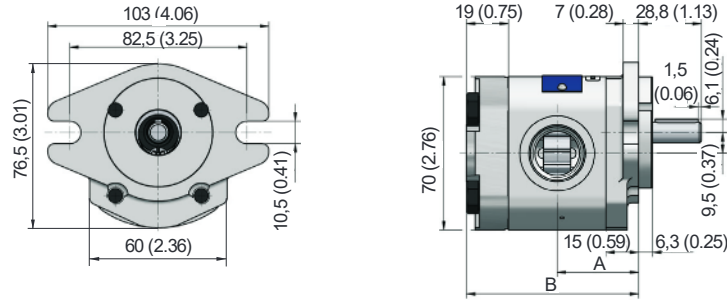

Displacement [cm ³ (in ³)/rev]	A	B	Displacement [cm ³ (in ³)/rev]	A	B
0,8 (0.05)	32,6 (1.28)	69,3 (2.73)	3,6 (0.22)	37,8 (1.49)	79,6 (3.13)
1,2 (0.07)	33,4 (1.31)	70,8 (2.79)	4,4 (0.27)	39,2 (1.54)	82,5 (3.25)
1,6 (0.10)	34,1 (1.34)	72,3 (2.85)	4,8 (0.29)	40,0 (1.57)	84,0 (3.31)
2,1 (0.13)	34,9 (1.37)	73,9 (2.91)	5,8 (0.35)	41,9 (1.65)	87,8 (3.46)
2,5 (0.15)	35,7 (1.41)	75,5 (2.97)	6,2 (0.38)	42,6 (1.68)	89,3 (3.53)
3,3 (0.20)	37,2 (1.46)	78,5 (3.09)	7,9 (0.48)	45,8 (1.80)	95,6 (3.76)

GP1-*R-RBCC-SHDUD-N

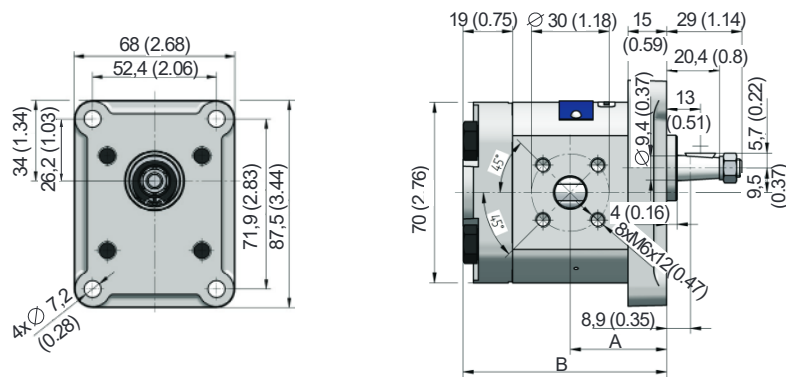

Displacement [cm ³ (in ³)/rev]	A	B	Displacement [cm ³ (in ³)/rev]	A	B
0,8 (0.05)	32,6 (1.28)	69,3 (2.73)	3,6 (0.22)	37,8 (1.49)	79,6 (3.13)
1,2 (0.07)	33,4 (1.31)	70,8 (2.79)	4,4 (0.27)	39,2 (1.54)	82,5 (3.25)
1,6 (0.10)	34,1 (1.34)	72,3 (2.85)	4,8 (0.29)	40,0 (1.57)	84,0 (3.31)
2,1 (0.13)	34,9 (1.37)	73,9 (2.91)	5,8 (0.35)	41,9 (1.65)	87,8 (3.46)
2,5 (0.15)	35,7 (1.41)	75,5 (2.97)	6,2 (0.38)	42,6 (1.68)	89,3 (3.53)
3,3 (0.20)	37,2 (1.46)	78,5 (3.09)	7,9 (0.48)	45,8 (1.80)	95,6 (3.76)

GP1-*L-ADKD-AGBPA-N

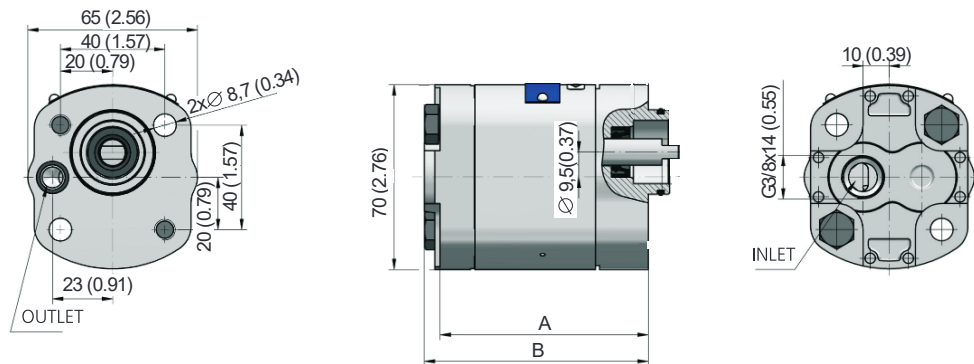

Displacement [cm ³ (in ³)/rev]	A	B	Displacement [cm ³ (in ³)/rev]	A	B
0,8 (0.05)	68,3 (2.69)	74,3 (2.93)	3,6 (0.22)	78,6 (3.09)	84,6 (3.33)
1,2 (0.07)	69,8 (2.75)	75,8 (2.98)	4,4 (0.27)	81,5 (3.21)	81,5 (3.21)
1,6 (0.10)	71,3 (2.81)	77,3 (3.04)	4,8 (0.29)	83,0 (3.27)	89,0 (3.50)
2,1 (0.13)	72,9 (2.87)	78,9 (3.11)	5,8 (0.35)	86,8 (3.42)	92,8 (3.65)
2,5 (0.15)	74,5 (2.93)	80,5 (3.17)	6,2 (0.38)	88,3 (3.48)	94,3 (3.71)
3,3 (0.20)	77,5 (3.05)	83,5 (3.29)	7,9 (0.48)	94,6 (3.72)	100,6 (3.96)

GP1 Pumps - basic design in millimeters (inches)

GP1-*/L-ACKA-CGBPA/GBGBGB-N

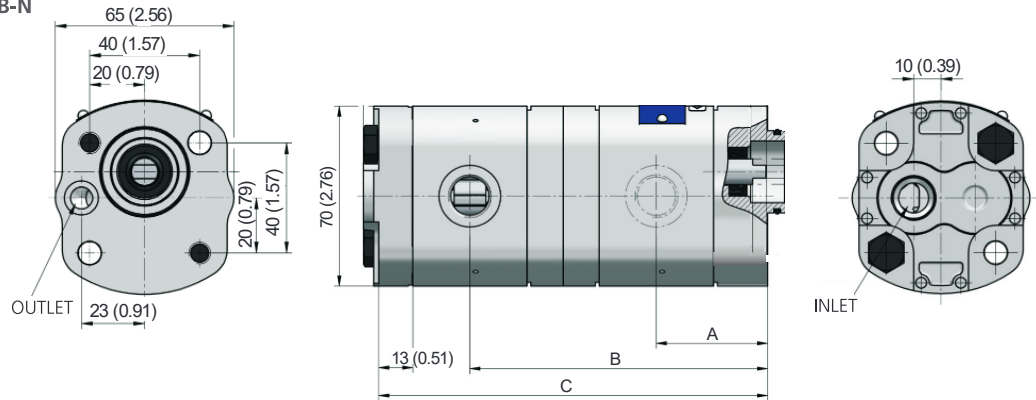

Displacement [cm ³ (in ³)/rev]	A	B	C	Displacement [cm ³ (in ³)/rev]	A	B	C
1,6 / 4,8 (0.10 / 0.29)	40,1 (1.58)	112,3 (4.42)	150,3 (5.92)	3,3 / 4,4 (0.20 / 0.27)	43,2 (1.70)	117,7 (4.63)	155,0 (6.10)
1,6 / 5,8 (0.10 / 0.35)	40,1 (1.58)	114,2 (4.50)	154,1 (6.07)	6,2 / 1,6 (0.38 / 0.10)	48,6 (1.91)	123,4 (4.86)	155,6 (6.13)
1,6 / 6,2 (0.10 / 0.38)	40,1 (1.58)	115,0 (4.53)	155,6 (6.13)	7,9 / 1,2 (0.48 / 0.07)	51,8 (2.04)	129,0 (5.08)	160,4 (6.31)
2,5 / 4,4 (0.15 / 0.27)	41,7 (1.64)	114,7 (4.52)	152,0 (5.98)	7,9 / 2,5 (0.48 / 0.15)	51,8 (2.04)	131,4 (5.17)	165,1 (6.50)
2,5 / 4,8 (0.15 / 0.29)	41,7 (1.64)	115,5 (4.55)	153,5 (6.04)				

GP1-*R-RBCB-SGBGB-N002

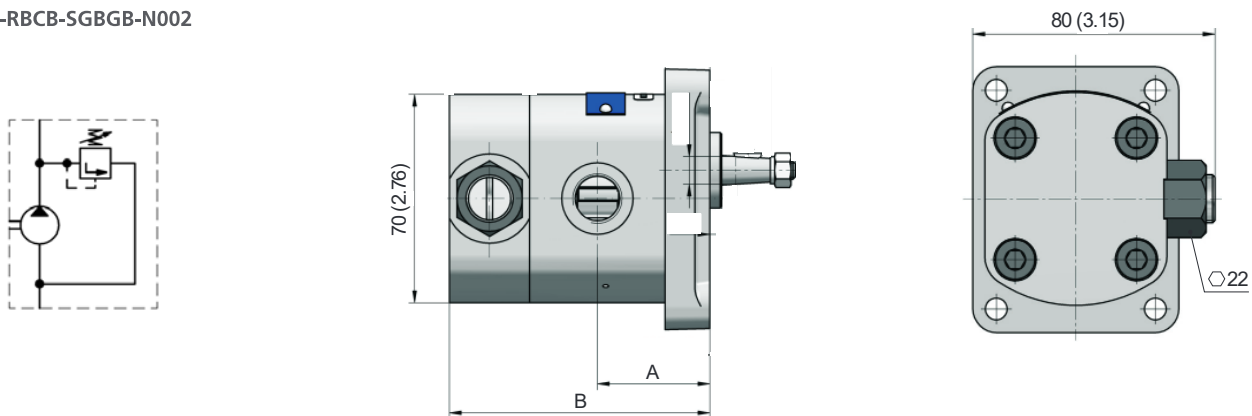

Displacement [cm ³ (in ³)/rev]	A	B	Displacement [cm ³ (in ³)/rev]	A	B
0,8 (0.05)	32,6 (1.28)	77,3 (3.04)	3,6 (0.22)	37,8 (1.49)	87,6 (3.45)
1,2 (0.07)	33,4 (1.31)	78,8 (3.10)	4,4 (0.27)	39,2 (1.54)	90,5 (3.56)
1,6 (0.10)	34,1 (1.34)	80,3 (3.16)	4,8 (0.29)	40,0 (1.57)	92,0 (3.62)
2,1 (0.13)	34,9 (1.37)	81,9 (3.22)	5,8 (0.35)	41,9 (1.65)	95,8 (3.77)
2,5 (0.15)	35,7 (1.41)	83,5 (3.29)	6,2 (0.38)	42,6 (1.68)	97,3 (3.83)
3,3 (0.20)	37,2 (1.46)	86,5 (3.41)	7,9 (0.48)	45,8 (1.80)	103,6 (4.08)

GP1 Pumps - special design in millimeters (inches)

Single pump GP1-L-AGCG-AGBPA-N014**

Double pump GP1-/**L-AGCG-CGBPA/GBGBGB-N014**

014 - Special design for SMA 05 hydraulic units:

Flange AE with pressure port PA

Shaft prolonged

