

Fluid Cooling Shell & Tube UC / UCV Series

STEEL & STAINLESS STEEL CONSTRUCTION

Performance Notes

- Steam & large temperature differentials
- "U" tube
- Removable tube bundle for servicing
- Reduces thermal expansion stresses
- 3/8" Tubes
- Built-in expansion chamber
- Threaded or flanged connections
- Mounting brackets included
- Steel shell assembly



Options
 Wide variety of materials available
 Custom sizes/designs
 Stainless steel hardware and mounting

Ratings

UC Series

Maximum Operating Pressure - Shell Side
 250 PSI

Maximum Operating Pressure - Tube Side
 150 PSI

Maximum Operating Temperature
 400°F

UCV Series

Maximum Operating Pressure - Shell Side
600, 800, 1000 250 psi
1200, 1700 150 psi

Maximum Operating Pressure - Tube Side
 150 PSI

Maximum Operating Temperature
 400°F

Materials

UC/UCV Series

Tubes Copper

Tube Sheets Steel

Shell Steel/316L stainless steel (UCV)

Shell Connections Steel

Baffles Stainless steel

End Bonnets Cast iron

Mounting Brackets Steel

Gaskets Non-asbestos fiber/nitrile rubber

Nameplate Aluminum foil

Materials

USSC/USSCV Series

Tubes 316L stainless steel

Tube Sheets 316L stainless steel

Shell 316L stainless steel

Shell Connections 316L stainless steel

Baffles 316L stainless steel

End Bonnets 316L stainless steel

Mounting Brackets Steel

Gaskets Non-asbestos fiber/nitrile rubber

How to Order

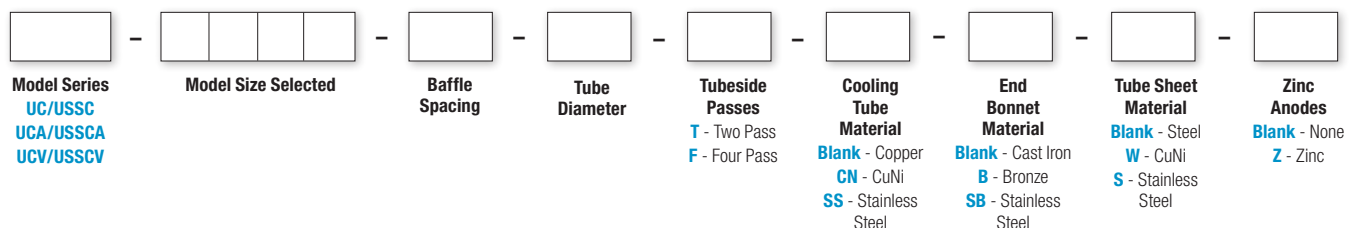

UC/USSC = NPT Shell Connections; NPT Tube Connections

UCA/USSCA = ASME/ANSI Flange Shell Connections, NPT Tube Connections

UCV/USSCV = 1000 and Smaller: Inlet and Outlet NPT Shell Connections Rotated 180°, NPT Tube Side Connections

UCV/USSCV = 1200 and Larger: ASME/ANSI Flange Inlet and NPT Outlet Shell Connections Rotated 180°, NPT Tube Side Connections

Dimensions

UC Two Pass

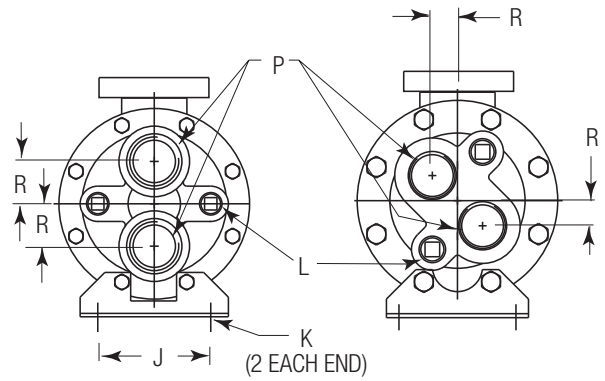
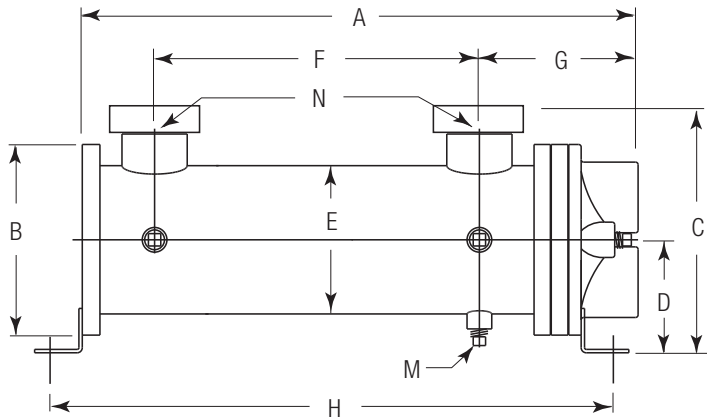

All models except
UC-800 & UC-1200 Series

UC-800 &
UC-1200 Series

Model	A	B Dia.	C		D	E Dia.	F	G	H	J	K	L NPT	M NPT	N NPT	P NPT	R	FT ² Surface Area
			NPT	ASME* Flange													
612	17.22	4.50	5.38	6.75	2.75	3.25	11.25	4.03	17.66	3.25	.44 Dia	(2) .38	(3) .25	1.00	1.00	—	2.4
624	29.22	4.50	5.38	6.75	2.75	3.25	23.25	4.03	29.66	3.25	.44 Dia	(2) .38	(3) .25	1.00	1.00	—	4.7
812	19.47	6.00	6.75	8.25	3.50	4.25	12.00	4.97	19.65	3.50	.44 Dia	(2) .38	(3) .25	1.50	1.25	0.75	4.0
824	31.47	6.00	6.75	8.25	3.50	4.25	24.00	4.97	31.65	3.50	.44 Dia	(2) .38	(3) .25	1.50	1.25	0.75	7.9
836	43.47	6.00	6.75	8.25	3.50	4.25	36.00	4.97	43.65	3.50	.44 Dia	(2) .38	(3) .25	1.50	1.25	0.75	11.9
1012	19.68	6.75	7.75	9.25	4.00	5.25	11.50	5.62	19.94	4.00	.50 x .75 Slot	(2) .38	(3) .38	1.50	1.50	1.50	7.4
1024	31.68	6.75	7.75	9.25	4.00	5.25	23.50	5.62	31.94	4.00	.50 x .75 Slot	(2) .38	(3) .38	1.50	1.50	1.50	14.5
1036	43.68	6.75	7.75	9.25	4.00	5.25	35.50	5.62	43.94	4.00	.50 x .75 Slot	(2) .38	(3) .38	1.50	1.50	1.50	21.5
1218	26.22	7.75	8.75	10.38	4.50	6.25	17.38	5.89	26.12	5.00	.50 x .75 Slot	(2) .50	(3) .38	2.00	2.00	1.10	15.3
1224	32.22	7.75	8.75	10.38	4.50	6.25	23.38	5.89	32.12	5.00	.50 x .75 Slot	(2) .50	(3) .38	2.00	2.00	1.10	21.1
1236	44.22	7.75	8.75	10.38	4.50	6.25	35.38	5.89	44.12	5.00	.50 x .75 Slot	(2) .50	(3) .38	2.00	2.00	1.10	31.3
1248	56.22	7.75	8.75	10.38	4.50	6.25	47.38	5.89	56.12	5.00	.50 x .75 Slot	(2) .50	(3) .38	2.00	2.00	1.10	41.6
1724	34.69	10.50	11.58	13.00	5.75	8.62	23.50	7.81	34.27	7.00	.62 x .88 Slot	(2) .50	(3) .38	3.00	2.50	2.25	47.7
1736	46.69	10.50	11.58	13.00	5.75	8.62	35.50	7.81	46.27	7.00	.62 x .88 Slot	(2) .50	(3) .38	3.00	2.50	2.25	70.1
1748	58.69	10.50	11.58	13.00	5.75	8.62	47.50	7.81	58.27	7.00	.62 x .88 Slot	(2) .50	(3) .38	3.00	2.50	2.25	92.5
1760	70.69	10.50	11.58	13.00	5.75	8.62	59.50	7.81	70.27	7.00	.62 x .88 Slot	(2) .50	(3) .38	3.00	2.50	2.25	114.8

*150# ASME/ANSI Flange (Optional). NOTE: We reserve the right to make reasonable design changes without notice. Consult factory. All dimensions are inches.

Dimensions

UC Four Pass

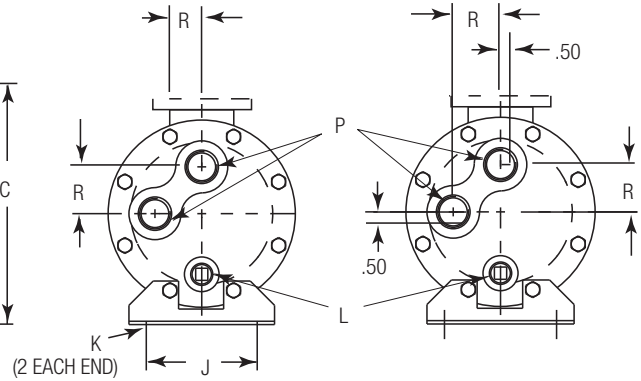
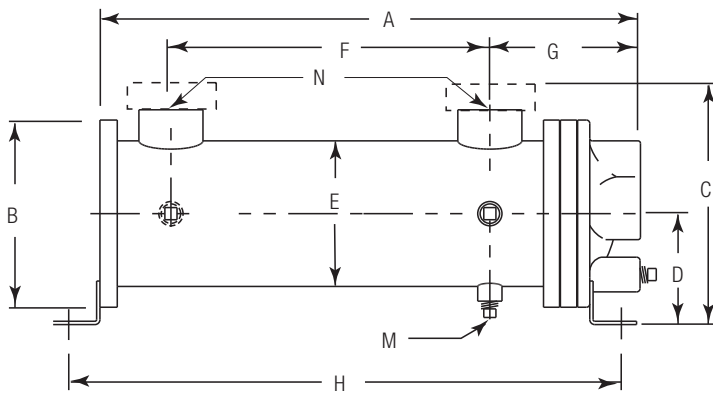

All models except
UC-1700 Series

UC-1700 Series

Model	A	B Dia.	C		D	E Dia.	F	G	H	J	K	L NPT	M NPT	N NPT	P NPT	R	FT ² Surface Area
			NPT	ASME* Flange													
612	17.20	4.50	5.38	6.75	2.75	3.25	11.25	4.01	17.66	3.25	.44 Dia	—	(3) .25	1.00	.75	1.00	2.4
624	29.20	4.50	5.38	6.75	2.75	3.25	23.25	4.01	29.66	3.25	.44 Dia	—	(3) .25	1.00	.75	1.00	4.7
812	19.47	6.00	6.75	8.25	3.50	4.25	12.00	4.97	19.65	3.50	.44 Dia	(2) .38	(3) .25	1.50	.75	0.75	4.0
824	31.47	6.00	6.75	8.25	3.50	4.25	24.00	4.97	31.65	3.50	.44 Dia	(2) .38	(3) .25	1.50	.75	1.25	7.9
836	43.47	6.00	6.75	8.25	3.50	4.25	36.00	4.97	43.65	3.50	.44 Dia	(2) .38	(3) .25	1.50	.75	1.25	11.9
1012	19.50	6.75	7.75	9.25	4.00	5.25	11.50	5.43	19.95	4.00	.50 x .75 Slot	(2) .38	(3) .38	1.50	1.00	1.69	7.4
1024	31.50	6.75	7.75	9.25	4.00	5.25	23.50	5.43	31.95	4.00	.50 x .75 Slot	(2) .38	(3) .38	1.50	1.00	1.69	14.5
1036	43.50	6.75	7.75	9.25	4.00	5.25	35.50	5.43	43.95	4.00	.50 x .75 Slot	(2) .38	(3) .38	1.50	1.00	1.69	21.5
1218	26.22	7.75	8.75	10.38	4.50	6.25	17.38	5.89	26.12	5.00	.50 x .75 Slot	(2) .38	(3) .38	2.00	1.50	2.00	15.3
1224	32.22	7.75	8.75	10.38	4.50	6.25	23.38	5.89	32.12	5.00	.50 x .75 Slot	(2) .38	(3) .38	2.00	1.50	2.00	21.1
1236	44.22	7.75	8.75	10.38	4.50	6.25	35.38	5.89	44.12	5.00	.50 x .75 Slot	(2) .38	(3) .38	2.00	1.50	2.00	31.3
1248	56.22	7.75	8.75	10.38	4.50	6.25	47.38	5.89	56.12	5.00	.50 x .75 Slot	(2) .38	(3) .38	2.00	1.50	2.00	41.6
1724	34.69	10.50	11.58	13.00	5.75	8.62	23.50	7.81	34.27	7.00	.62 x .88 Slot	(2) .38	(3) .38	3.00	2.00	2.50	47.7
1736	46.69	10.50	11.58	13.00	5.75	8.62	35.50	7.81	46.27	7.00	.62 x .88 Slot	(2) .38	(3) .38	3.00	2.00	2.50	70.1
1748	58.69	10.50	11.58	13.00	5.75	8.62	47.50	7.81	58.27	7.00	.62 x .88 Slot	(2) .38	(3) .38	3.00	2.00	2.50	92.5
1760	70.69	10.50	11.58	13.00	5.75	8.62	59.50	7.81	70.27	7.00	.62 x .88 Slot	(2) .38	(3) .38	3.00	2.00	2.50	114.8

*150# ASME/ANSI Flange (Optional). NOTE: We reserve the right to make reasonable design changes without notice. Consult factory. All dimensions are inches.

UC Applications

U-Tube Heat Exchangers allow the shell and tube bundle to expand and contract independently with temperature fluctuation. This reduces temperature dependent stresses so they are ideal in applications with large temperature differentials. Some typical examples for **UC** units include quench oil coolers, liquid to liquid heaters, and barrel oil coolers for plastic extrusion machines. The removable bundle design allows for easier cleaning of the shell side cavity when the bundle is removed.

Piping Diagram

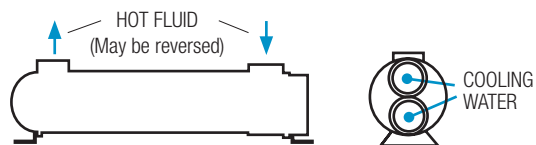

Specific applications may have different piping arrangements. Contact factory for assistance.

Dimensions

UCV Two Pass

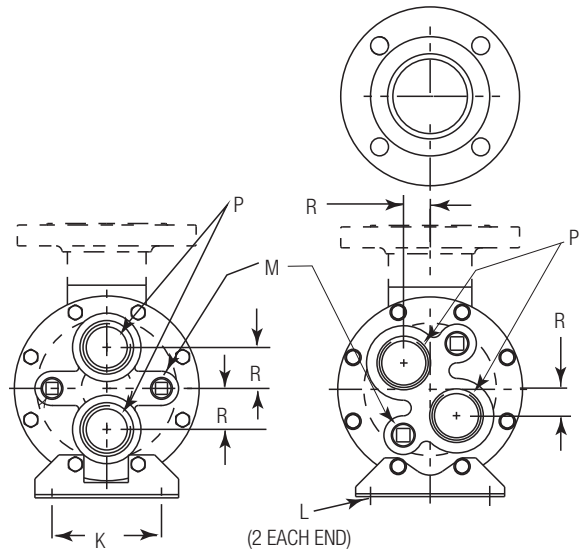
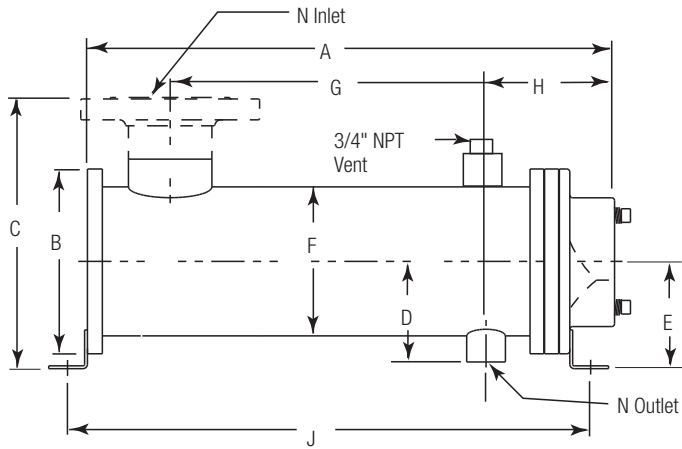

All models except
UCV-800 &
UCV-1200 Series

UCV-800 &
UC-1200 Series

Model	A	B Dia.	C	D	E	F Dia.	G	H	J	K	L	M NPT	N		P NPT	R	FT ² Surface Area
													Inlet	Outlet			
612	17.22	4.50	5.25	2.62	2.75	3.25	11.00	4.00	17.66	3.25	.44 Dia	(2) .38	1.25	.75	1.00	—	2.4
624	29.22	4.50	5.25	2.62	2.75	3.25	23.00	4.00	29.66	3.25	.44 Dia	(2) .38	1.25	.75	1.00	—	4.7
812	19.47	6.00	6.75	3.15	3.50	4.25	12.38	4.60	19.65	3.50	.44 Dia	(2) .38	1.50	.75	1.25	.75	4.0
824	31.47	6.00	6.75	3.15	3.50	4.25	24.38	4.60	31.65	3.50	.44 Dia	(2) .38	1.50	.75	1.25	.75	7.9
836	43.47	6.00	6.75	3.15	3.50	4.25	36.38	4.60	43.65	3.50	.44 Dia	(2) .38	1.50	.75	1.25	.75	11.9
1012	19.68	6.75	7.77	3.70	4.00	5.25	11.50	5.37	19.94	4.00	.50 x .75 Slot	(2) .38	2.00	1.00	1.50	1.50	7.4
1024	31.68	6.75	7.77	3.70	4.00	5.25	23.50	5.37	31.94	4.00	.50 x .75 Slot	(2) .38	2.00	1.00	1.50	1.50	14.5
1036	43.68	6.75	7.77	3.70	4.00	5.25	35.50	5.37	43.94	4.00	.50 x .75 Slot	(2) .38	2.00	1.00	1.50	1.50	21.5
1218	26.22	7.75	11.38	4.22	4.50	6.25	17.38	5.38	26.12	5.00	.50 x .75 Slot	(2) .50	3.00*	1.00	2.00	1.10	15.3
1224	32.22	7.75	11.38	4.22	4.50	6.25	23.38	5.38	32.12	5.00	.50 x .75 Slot	(2) .50	3.00*	1.00	2.00	1.10	21.1
1236	44.22	7.75	11.38	4.22	4.50	6.25	35.38	5.38	44.12	5.00	.50 x .75 Slot	(2) .50	3.00*	1.00	2.00	1.10	31.3
1248	56.22	7.75	11.38	4.22	4.50	6.25	47.38	5.38	56.12	5.00	.50 x .75 Slot	(2) .50	3.00*	1.00	2.00	1.10	41.6
1724	34.69	10.50	14.00	5.58	5.75	8.62	23.00	7.31	34.27	7.00	.62 x .88 Slot	(2) .50	4.00*	1.50	2.50	2.25	47.7
1736	46.69	10.50	14.00	5.58	5.75	8.62	35.00	7.31	46.27	7.00	.62 x .88 Slot	(2) .50	4.00*	1.50	2.50	2.25	70.1
1748	58.69	10.50	14.00	5.58	5.75	8.62	47.00	7.31	58.27	7.00	.62 x .88 Slot	(2) .50	4.00*	1.50	2.50	2.25	92.5
1760	70.69	10.50	14.00	5.58	5.75	8.62	59.00	7.31	70.27	7.00	.62 x .88 Slot	(2) .50	4.00*	1.50	2.50	2.25	114.8

*150# ASME/ANSI Flange. NOTE: We reserve the right to make reasonable design changes without notice. Consult factory. All dimensions are inches.

Dimensions

UCV Four Pass

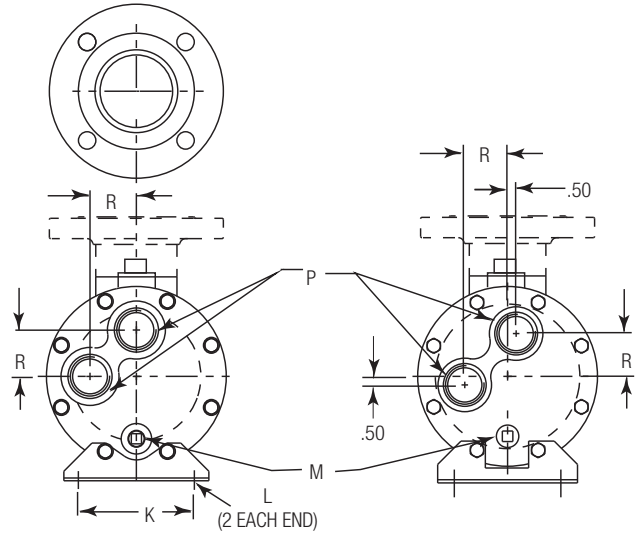
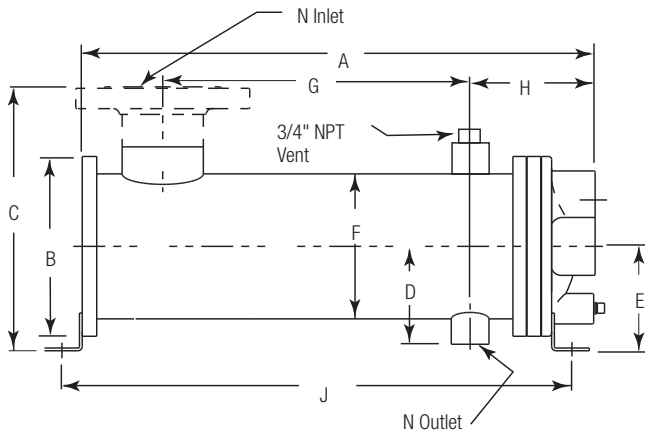

All models except UCV-1700 Series

UCV-1700 Series

Model	A	B Dia.	C	D	E	F Dia.	G	H	J	K	L	M NPT	N		P NPT	R	FT ² Surface Area
													Inlet	Outlet			
612	17.20	4.50	5.25	2.62	2.75	3.25	11.00	3.98	17.66	3.25	.44 Dia	(2) .38	1.25	.75	.75	1.00	2.4
624	29.20	4.50	5.25	2.62	2.75	3.25	23.00	3.98	29.66	3.25	.44 Dia	(2) .38	1.25	.75	.75	1.00	4.7
812	19.47	6.00	6.75	3.15	3.50	4.25	12.38	4.60	19.65	3.50	.44 Dia	(2) .38	1.50	.75	.75	1.25	4.0
824	31.47	6.00	6.75	3.15	3.50	4.25	24.38	4.60	31.65	3.50	.44 Dia	(2) .38	1.50	.75	.75	1.25	7.9
836	43.47	6.00	6.75	3.15	3.50	4.25	36.38	4.60	43.65	3.50	.44 Dia	(2) .38	1.50	.75	.75	1.25	11.9
1012	19.50	6.75	7.77	3.70	4.00	5.25	11.50	5.18	19.95	4.00	.50 x .75 Slot	(2) .38	2.00	1.00	1.00	1.69	7.4
1024	31.50	6.75	7.77	3.70	4.00	5.25	23.50	5.18	31.95	4.00	.50 x .75 Slot	(2) .38	2.00	1.00	1.00	1.69	14.5
1036	43.50	6.75	7.77	3.70	4.00	5.25	35.50	5.18	43.95	4.00	.50 x .75 Slot	(2) .38	2.00	1.00	1.00	1.69	21.5
1218	26.22	7.75	11.38	4.22	4.50	6.25	17.38	5.38	26.12	5.00	.50 x .75 Slot	(2) .38	3.00*	1.00	1.50	2.00	15.3
1224	32.22	7.75	11.38	4.22	4.50	6.25	23.38	5.38	32.12	5.00	.50 x .75 Slot	(2) .38	3.00*	1.00	1.50	2.00	21.1
1236	44.22	7.75	11.38	4.22	4.50	6.25	35.38	5.38	44.12	5.00	.50 x .75 Slot	(2) .38	3.00*	1.00	1.50	2.00	31.3
1248	56.22	7.75	11.38	4.22	4.50	6.25	47.38	5.38	56.12	5.00	.50 x .75 Slot	(2) .38	3.00*	1.00	1.50	2.00	41.6
1724	34.69	10.50	14.00	5.58	5.75	8.62	23.00	7.31	34.27	7.00	.62 x .88 Slot	(2) .38	4.00*	1.50	2.00	2.50	47.7
1736	46.69	10.50	14.00	5.58	5.75	8.62	35.00	7.31	46.27	7.00	.62 x .88 Slot	(2) .38	4.00*	1.50	2.00	2.50	70.1
1748	58.69	10.50	14.00	5.58	5.75	8.62	47.00	7.31	58.27	7.00	.62 x .88 Slot	(2) .38	4.00*	1.50	2.00	2.50	92.5
1760	70.69	10.50	14.00	5.58	5.75	8.62	59.00	7.31	70.27	7.00	.62 x .88 Slot	(2) .38	4.00*	1.50	2.00	2.50	114.8

*150# ASME/ANSI Flange. NOTE: We reserve the right to make reasonable design changes without notice. Consult factory. All dimensions are inches.

UCV Applications

U-Tube Heat Exchangers allow the shell and tube bundle to expand and contract independently with temperature fluctuation. This reduces temperature dependent stresses so they are ideal in applications with large temperature differentials. A typical example for **UCV** units is steam to liquid heaters. The removable bundle design allows for easier cleaning of the shell side cavity when the bundle is removed.

Piping Diagram

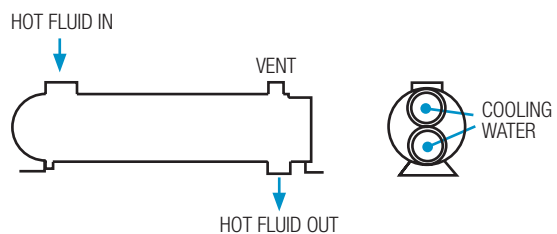

Specific applications may have different piping arrangements. Contact factory for assistance.