

Metal Filler Breather
Type SMBT-80
(Threaded Version)

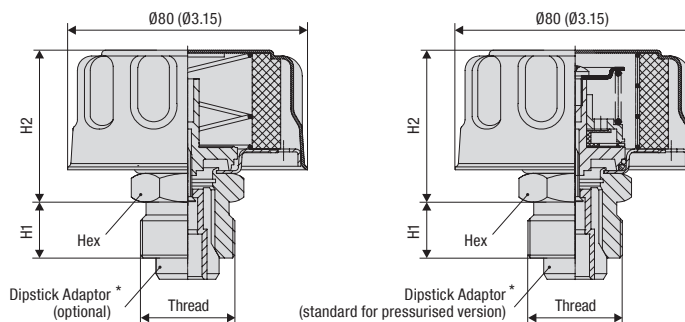

Without Pressurisation

Pressurised

* Please note: The dipstick adaptor is not available for connection threads G1/2 and 1/2 NPT.

Characteristics

Designed to be used as filler ports for hydraulic reservoirs, allowing the reservoir to breathe whilst protecting it from contamination found in harsh environments

Features

- Cap diameter of Ø80 mm / Ø3.15 in
- Threaded version, equipped with male BSP thread (ISO 228) or male NPT thread (ANSI B1.20.1)
- Operating temperature range: -30 °C ... +120 °C / -22 °F ... +248 °F

Materials

- Breather cap made of Steel, zinc/nickel-plated (Fe/Zn Ni 6) and free of hexavalent chromium CrVI (standard option); chrome-plated and epoxy-coated versions available
- Threaded socket made of Steel, zinc-plated
- Dipstick adaptor made of Polyamide (PA)

Contact STAUFF for alternative materials.

Accessories / Options

- Pressurisation up to 0,7 bar / 10 PSI
- Air filter element
- Dipstick adaptor suitable for plastic dipstick DS-1 (not for connection threads G1/2 and 1/2 NPT)
- Plastic dipstick DS-1 with integrated anti-splash feature (not for connection threads G1/2 and 1/2 NPT)
- Plastic dipstick with integrated magnet
- Oil Demister

Please see pages 26 and 47 for details.

Maximum Air Flow Rate

- 0,45 m³/min / 15.89 cfm

Contact STAUFF for detailed air flow curves.

Dimensions

Thread	Dimensions (mm/in)		
	H1	H2	Hex
Male G1/2 BSP (ISO 228)	14 .55	54 2.13	24 .94
Male G3/4 BSP (ISO 228)	16 .63	54 2.13	30 1.18
Male G1 BSP (ISO 228)	19 .75	54 2.13	36 1.42

Thread	Dimensions (mm/in)		
	H1	H2	Hex
Male 1/2 NPT (ANSI B1.20.1)	14 .51	52,5 2.07	24 .94
Male 3/4 NPT (ANSI B1.20.1)	16 .59	52,5 2.07	30 1.18
Male G1 NPT (ANSI B1.20.1)	19 .75	52,5 2.07	36 1.42

Order Codes

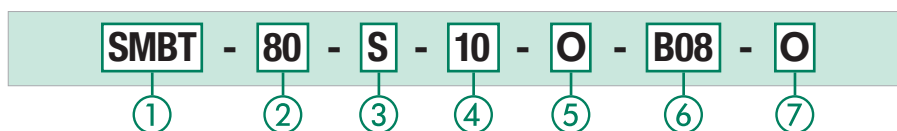

① Type / Version

Metal Filler Breather; Threaded version **SMBT**

② Cap Diameter / Material / Surface Finishing

Cap diameter Ø80 mm (Ø3.15 in); Breather cap made of Steel, zinc/nickel-plated (standard option) **80**
 Cap diameter Ø80 mm (Ø3.15 in); Breather cap made of Steel, chrome-plated **80C**
 Cap diameter Ø80 mm (Ø3.15 in); Breather cap made of Steel, epoxy-coated **80E**

③ Label

With STAUFF logo (standard option) **S**
 Neutral design without any logo **N**

④ Air Filter Element (Material / Micron Rating)

Without Breather Function **0**
 3 µm Filter Paper **03**
 10 µm Foam / PUR (standard option) **10**
 40 µm Foam / PUR **40**

Contact STAUFF for alternative materials / micron ratings.

⑤ Pressurisation

Without pressurisation (standard option) **0**
 Pressurised at 0,35 bar / 5 PSI **B0.35**
 Pressurised at 0,7 bar / 10 PSI **B0.7**

Please see page 26 for details.

⑥ Connection Thread (Male)

G1/2 **B08**
 G3/4 **B12**
 G1 **B16**
 1/2 NPT **N08**
 3/4 NPT **N12**
 1 NPT **N16**

Contact STAUFF for alternative threads.

⑦ Dipstick

Without dipstick (standard option) **0**
 With dipstick adaptor suitable for dipstick DS-1 (not for connection threads G1/2 and 1/2 NPT) **A**
 With dipstick adaptor and plastic dipstick DS-1 (300 mm / 11.81 in) with integrated anti-splash feature (not for connection threads G1/2 and 1/2 NPT) **D300**
 Plastic dipstick (300 mm / 11.81 in) with integrated magnet **D300M**

A shorter dipstick length can be achieved by simply cutting down the total length according to individual requirements.

Please note: The dipstick adaptor is required for the subsequent installation of plastic dipsticks DS-1 (see page 26 for details), and is included in delivery when ordering a pressurised version. The dipstick adaptor is not available for connection threads G1/2 and 1/2 NPT.

Dimensional drawings: All dimensions in mm (in).

