

P2/P3 Series Piston Pumps Variable Displacement

Catalog: HY28-1559-01/PT
Supercedes All Previous Versions

aerospace
climate control
electromechanical
filtration
fluid & gas handling
hydraulics
pneumatics
process control
sealing & shielding

Contents

General Information.....	3
Series P2 Ordering Information.....	4
Series P3 Ordering Information.....	5
P2/P3 Technical Data.....	6
P2/P3 Performance Data.....	12
P2 Performance and Dimension Section.....	13
Performance Data.....	14
Dimensional Data.....	23
P3 Performance and Dimension Section.....	41
Performance Data.....	42
Dimensional Data.....	51
P2/P3 Operating and Installation.....	62
Offer of Sale.....	63



WARNING - USER RESPONSIBILITY

FAILURE OR IMPROPER SELECTION OR IMPROPER USE OF THE PRODUCTS DESCRIBED HEREIN OR RELATED ITEMS CAN CAUSE DEATH, PERSONAL INJURY AND PROPERTY DAMAGE.

This document and other information from Parker-Hannifin Corporation, its subsidiaries and authorized distributors provide product or system options for further investigation by users having technical expertise.

The user, through its own analysis and testing, is solely responsible for making the final selection of the system and components and assuring that all performance, endurance, maintenance, safety and warning requirements of the application are met. The user must analyze all aspects of the application, follow applicable industry standards, and follow the information concerning the product in the current product catalog and in any other materials provided from Parker or its subsidiaries or authorized distributors.

To the extent that Parker or its subsidiaries or authorized distributors provide component or system options based upon data or specifications provided by the user, the user is responsible for determining that such data and specifications are suitable and sufficient for all applications and reasonably foreseeable uses of the components or systems.

OFFER OF SALE

The items described in this document are hereby offered for sale by Parker-Hannifin Corporation, its subsidiaries or its authorized distributor. This offer and its acceptance are governed by the provisions stated in the detailed "Offer of Sale" elsewhere in this document.

© Copyright 2009, Parker Hannifin Corporation. All Rights Reserved.

General Information

The newly developed variable displacement piston pumps from Parker Hannifin, designated “P2”, are intended for mobile applications, featuring a very compact design, low noise level and low pressure ripple.

The pumps are very stable and respond quickly to system demands in many different types of mobile machinery, and are designed for cost effective installation within the limited space available on modern mobile machines.

The P2 series is available in four frame sizes from 60 to 145 cm³/rev and features control options that are suitable for most mobile vehicle applications.

The P3 offers a built-in impeller to suit applications requiring higher self-priming speeds or when the vehicle is operating in high altitudes.

The P3 pump line is available in three frame sizes from 75 to 145 cm³/rev and features control options that are suitable for most mobile applications. Both of these pumps offer benefits like:

- **Compact and easy to install**
- **Less noise to insulate**
- **High self-priming speeds**
- **Gauge ports are standard**

P2 Series

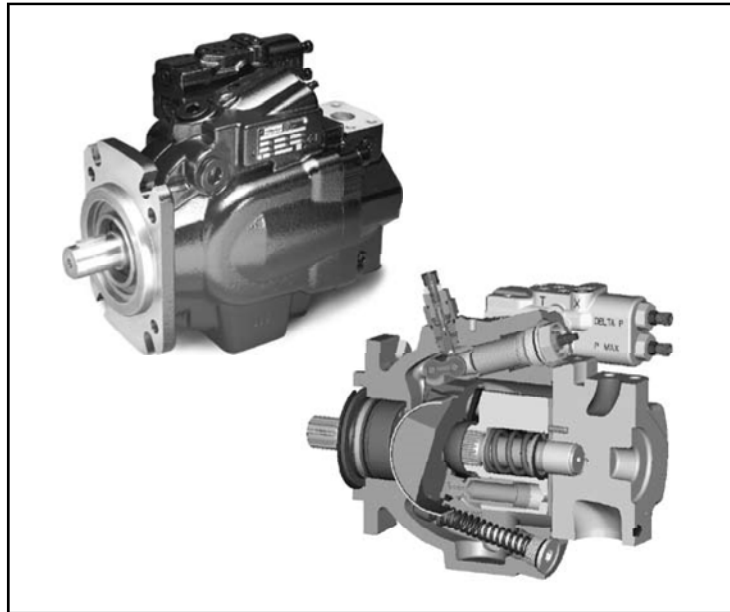

P3 Series

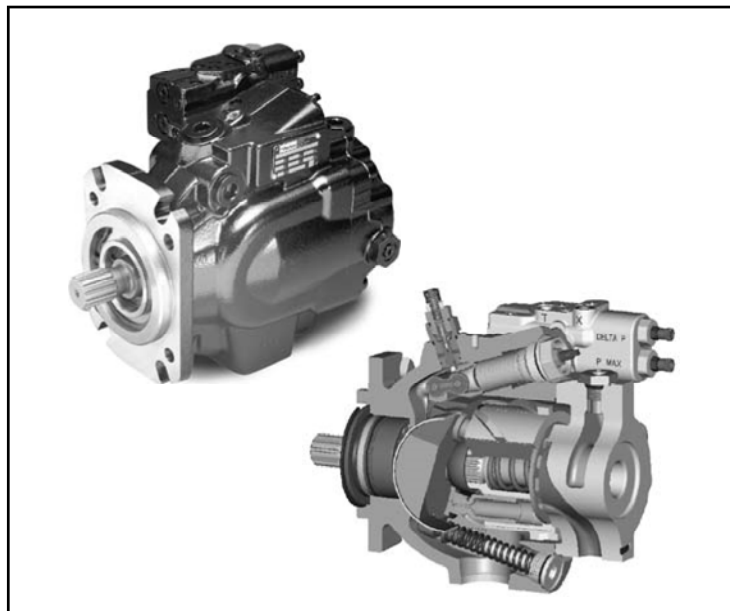

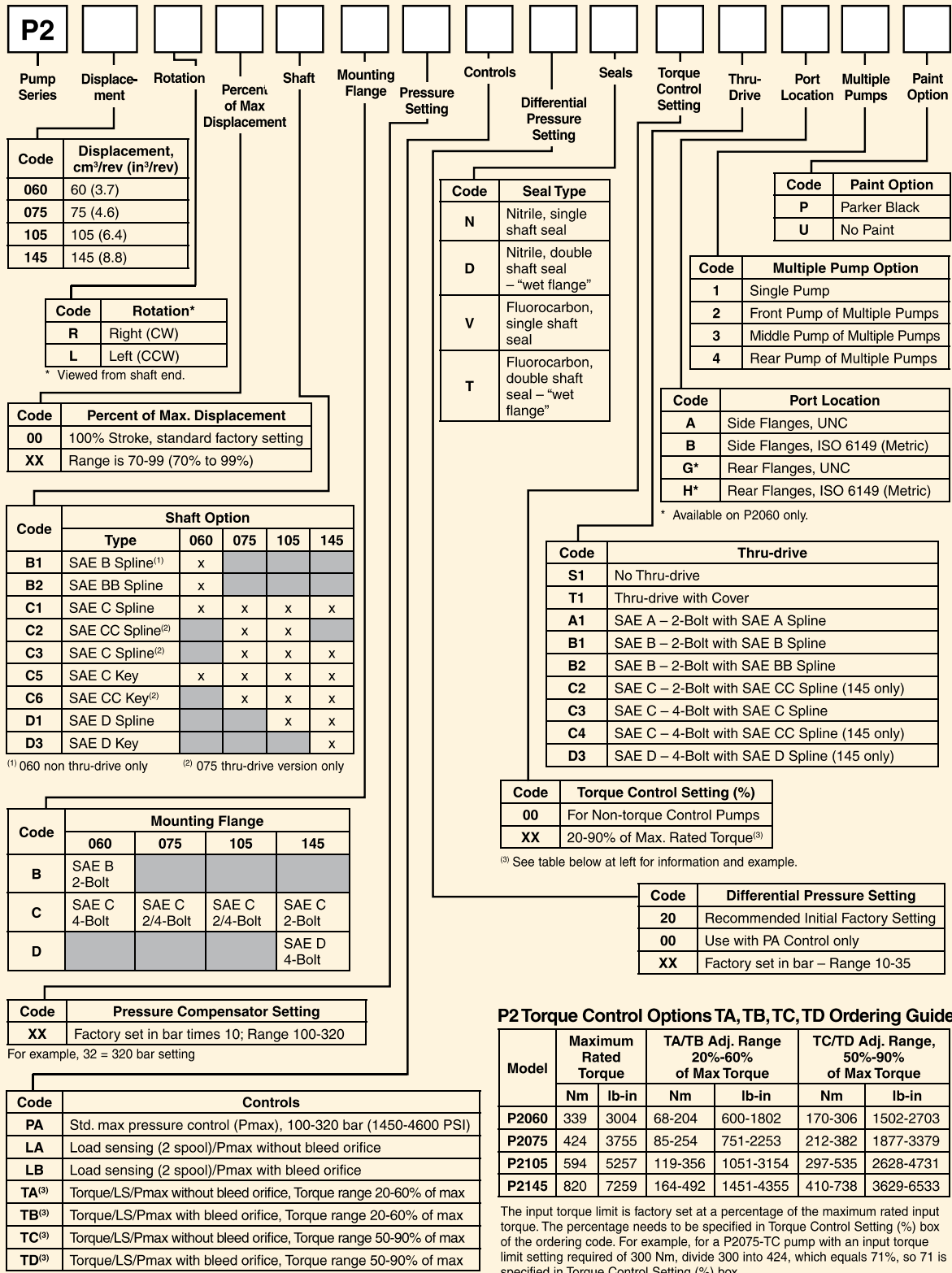

P2 Torque Control Options TA, TB, TC, TD Ordering Guide

Model	Maximum Rated Torque		TA/TB Adj. Range 20%-60% of Max Torque		TC/TD Adj. Range, 50%-90% of Max Torque	
	Nm	lb-in	Nm	lb-in	Nm	lb-in
P2060	339	3004	68-204	600-1802	170-306	1502-2703
P2075	424	3755	85-254	751-2253	212-382	1877-3379
P2105	594	5257	119-356	1051-3154	297-535	2628-4731
P2145	820	7259	164-492	1451-4355	410-738	3629-6533

The input torque limit is factory set at a percentage of the maximum rated input torque. The percentage needs to be specified in Torque Control Setting (%) box of the ordering code. For example, for a P2075-TC pump with an input torque limit setting required of 300 Nm, divide 300 into 424, which equals 71%, so 71 is specified in Torque Control Setting (%) box.

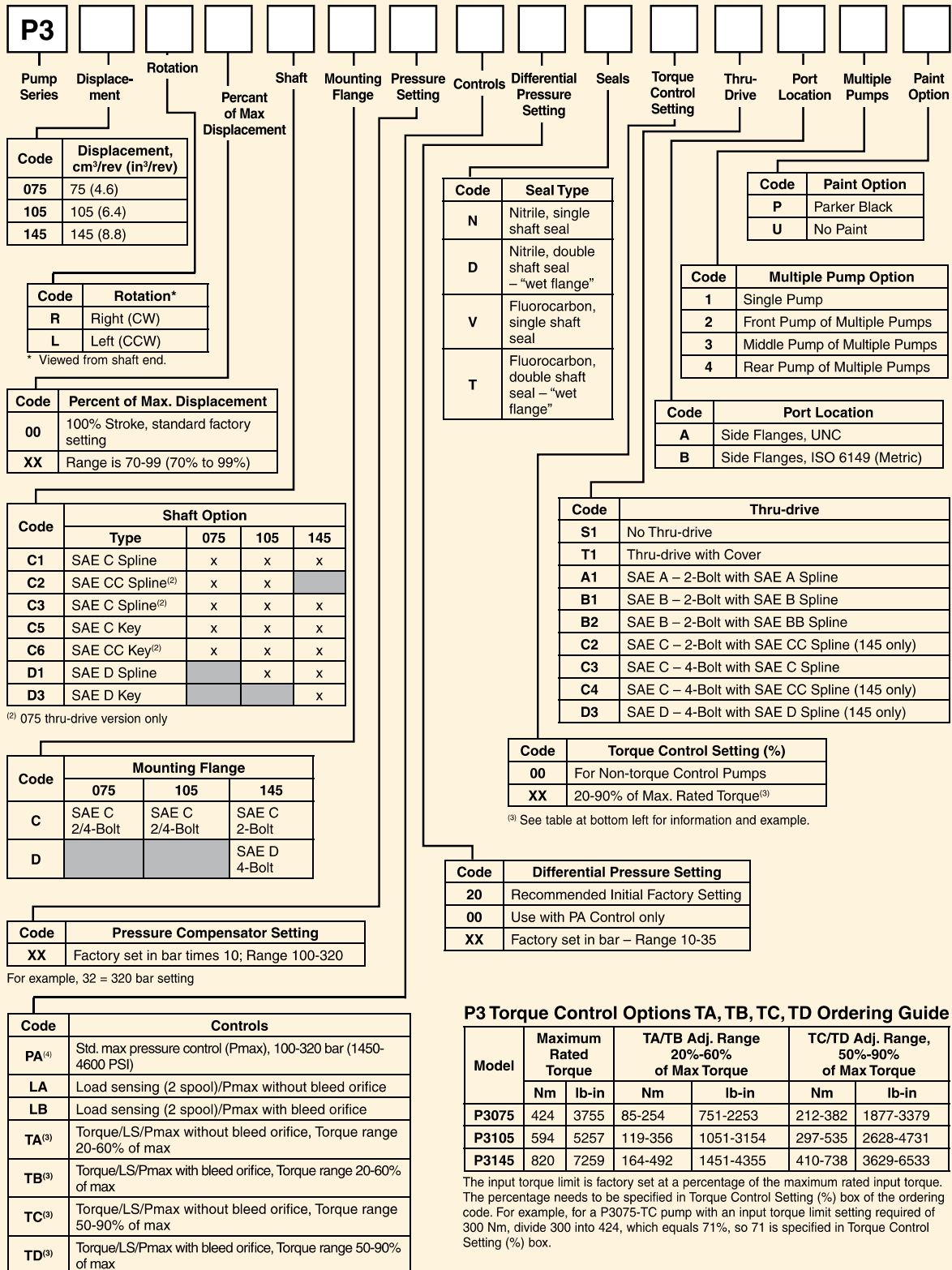

P3 Torque Control Options TA, TB, TC, TD Ordering Guide

Model	Maximum Rated Torque		TA/TB Adj. Range 20%-60% of Max Torque		TC/TD Adj. Range, 50%-90% of Max Torque	
	Nm	lb-in	Nm	lb-in	Nm	lb-in
P3075	424	3755	85-254	751-2253	212-382	1877-3379
P3105	594	5257	119-356	1051-3154	297-535	2628-4731
P3145	820	7259	164-492	1451-4355	410-738	3629-6533

The input torque limit is factory set at a percentage of the maximum rated input torque. The percentage needs to be specified in Torque Control Setting (%) box of the ordering code. For example, for a P3075-TC pump with an input torque limit setting required of 300 Nm, divide 300 into 424, which equals 71%, so 71 is specified in Torque Control Setting (%) box.

⁽³⁾ See table at left for information and example.

⁽⁴⁾ For Remote Pressure Compensator, order the “PA” model and remove plug from “X” port.

■ = Not Available

Technical Data

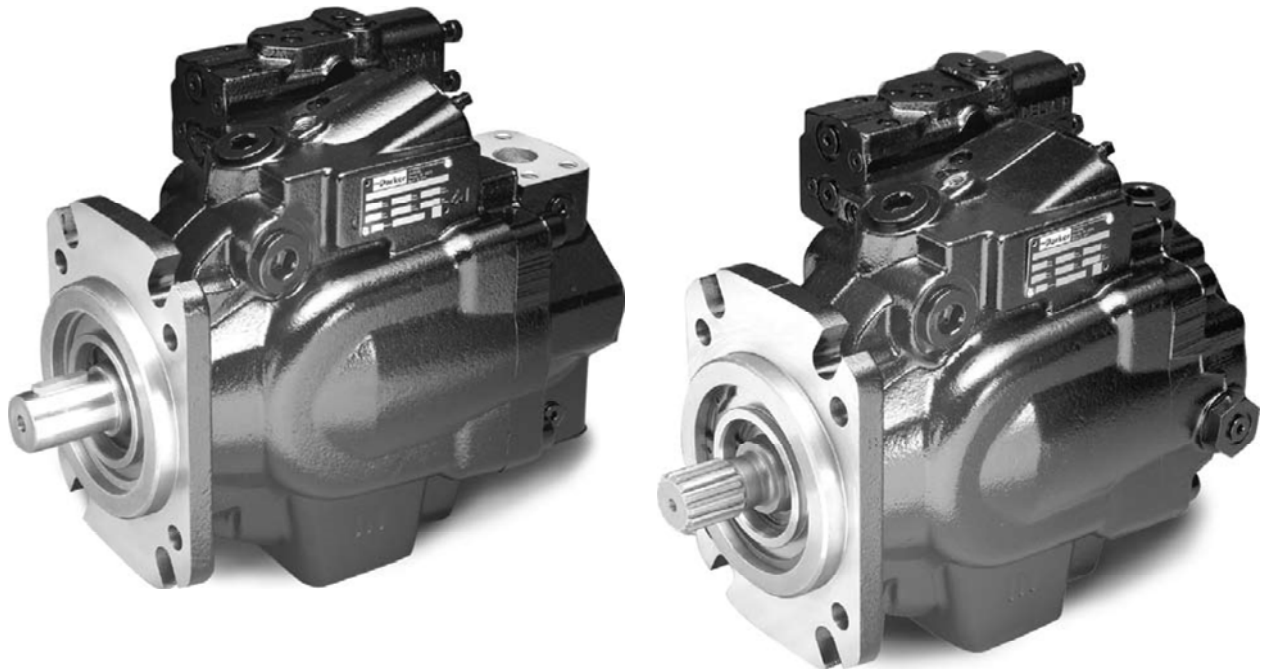

	P2 Series				P3 Series		
Frame size	P2060	P2075	P2105	P2145	P3075	P3105	P3145
Max displacement cm ³ /rev [cu in/rev]	60 3.66	75 4.58	105 6.41	145 8.85	75 4.58	105 6.41	145 8.85
Self-priming speed at 1 bar/14.5 psi abs. inlet pressure [rpm]	2800	2500	2300	2200	3000	2600	2500
Max continuous pressure bar [psi]	320 4600	320 4600	320 4600	320 4600	320 4600	320 4600	320 4600
Peak pressure bar [psi]	370 5365	370 5365	370 5365	370 5365	370 5365	370 5365	370 5365
Minimum Inlet Pressure bar abs at max speed [in Hg vacuum]	.8 5.8	.8 5.8	.8 5.8	.8 5.8	.8 5.8	.8 5.8	.8 5.8
Maximum Inlet Pressure bar [psi]	10 145	10 145	10 145	10 145	1.5 22.7	1.5 22.7	1.5 22.7
Maximum Case Drain Pressure bar continuous psi	.5 7.75	.5 7.75	.5 7.75	.5 7.75	1 14.5	1 14.5	1 14.5
Noise level at full flow, 1800 rpm, and 250 bar (3600 psi) [dBa]	74	76	78	80	76	78	80
Weight with load sense control kg [lbs]	37 81	44 97	63 139	78 172	42 92	62 136	76 167
Mass moment of inertia kg m ² (about axis of shaft)	.0061	.0101	.0168	.0241	.00106	.0177	.0264

P2/P3 Typical Control Characteristics

Typical Response Times

Input Speed: 1500 RPM

Fluid: Mineral Oil ISO VG 32 @ 40° C

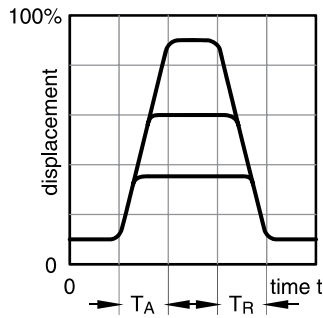

Size	Pressure Condition				
	Stand by to 250 bar	250 bar to stand by	50 bar to stand by	Stand by to 300 bar	300 bar to stand by
	Flow Condition				
	TA (ms) 0-100%	TR (ms) 100%-0	TR (ms) 100%-0	TA (ms) 0-100%	TR (ms) 100%-0
P2060	60	35	35	70	40
P2075	80	35	35	70	40
P2105	100	35	35	80	40
P2145	120	35	35	100	40
P3075	80	35	35	70	35
P3105	100	35	35	80	35
P3145	110	35	35	100	35

Differential Setting vs Standby Pressure

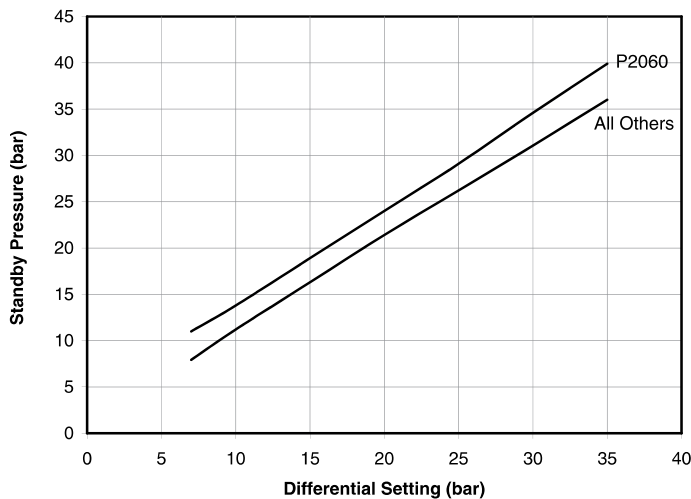

This chart shows the difference between differential pressure setting and stand by pressure. The P2060 utilizes a different control from the rest of the product family. "All others" refers to all other pump sizes P2 and P3 075 thru 145.

Control Option "PA"

Pressure Compensator Control

The pressure compensator control is used to limit the maximum system pressure. The control acts such that full pump displacement is achieved unless the system valve restricts the output flow or the load pressure reaches the maximum setting of the control. If pump flow is restricted by the system valve, the pump will provide only the flow demanded, but at the maximum pressure setting of the compensator control. If the outlet flow is completely blocked, the pump will destroke to zero displacement and maintain the pressure at the setting of the compensator spring.

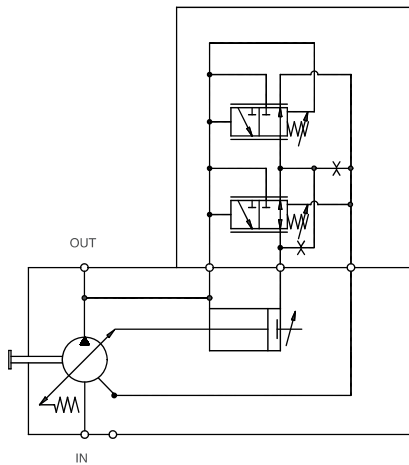
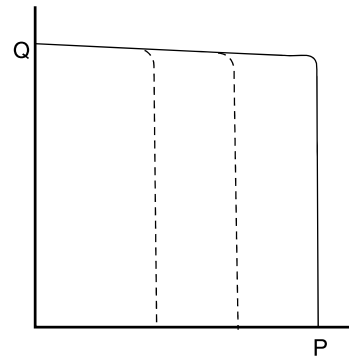

P2 Control Schematic

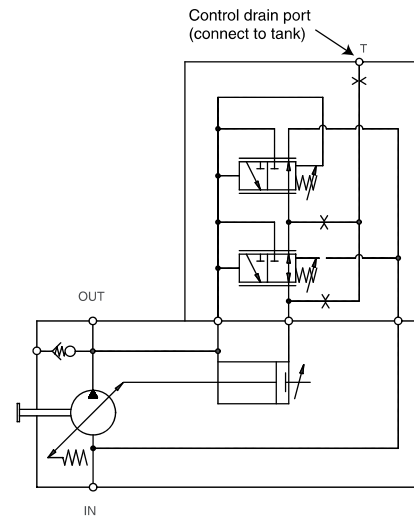

P3 Control Schematic

Control Option "RA"

Remote Pressure Compensator Control

This control allows the pump pressure compensator setting to be adjusted from a remote relief valve. The control acts such that full pump displacement is achieved unless the system valve restricts the output flow or the load pressure reaches the maximum setting of the control. If pump flow is restricted by the system valve, the pump will provide only the flow demanded, but at the maximum pressure setting of the compensator control. If the outlet flow is completely blocked, the pump will destroke to zero displacement and maintain the pressure at the setting of the remote relief valve.

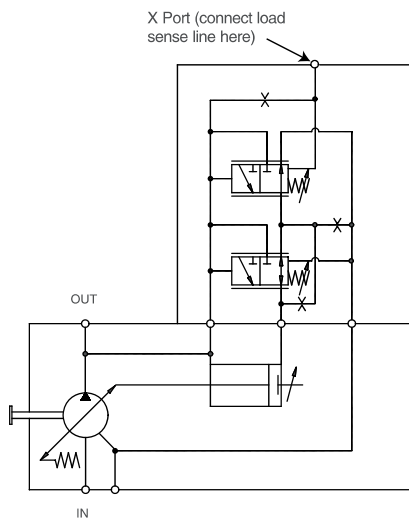
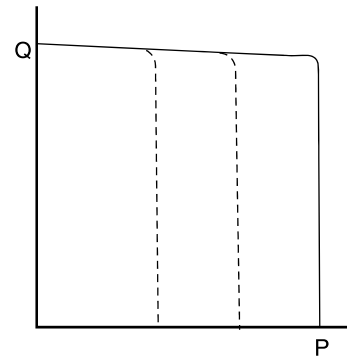

P2 Control Schematic

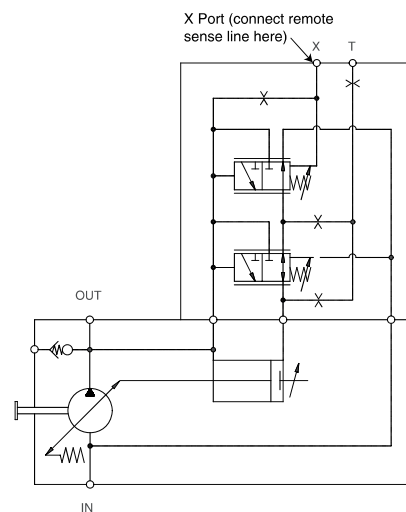

P3 Control Schematic

Control Options “LA” and “LB”

Load sensing controls with maximum pressure cut off

These controls feature load sensing and maximum pressure compensation. Load sense controls are used to match pump flow and pressure to system demands, thus minimizing losses due to wasted horsepower. The pump automatically adjusts for changes in drive speed and load pressures to match the pump output flow to the load requirement. Since the pump load sense control will maintain a constant pressure drop across the main system throttling valve, the flow rate will remain constant, independent of changes in load pressure and pump shaft speed.

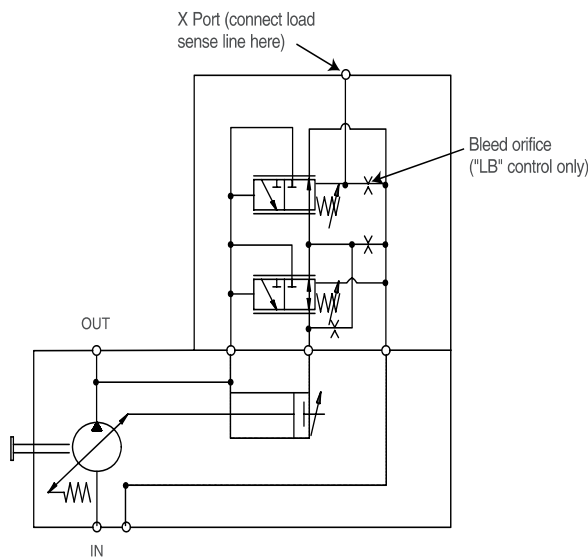
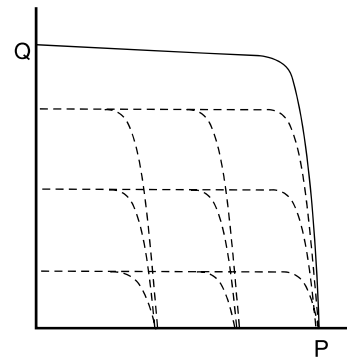

P2 Control Schematic

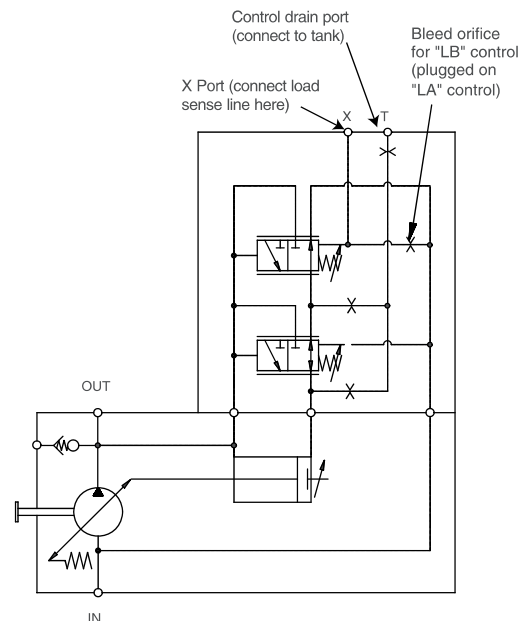

P3 Control Schematic

Control Options "TA", "TB", "TC" and "TD"

Torque limiting control with load sensing and maximum pressure limiter

These controls provide the benefits of the load sensing and pressure limiting controls, plus the ability to limit the input torque the pump will draw. These controls are beneficial when the power available from the prime mover for the hydraulics is limited or the application power demand has both high flow / low pressure and low flow / high pressure duty cycles.

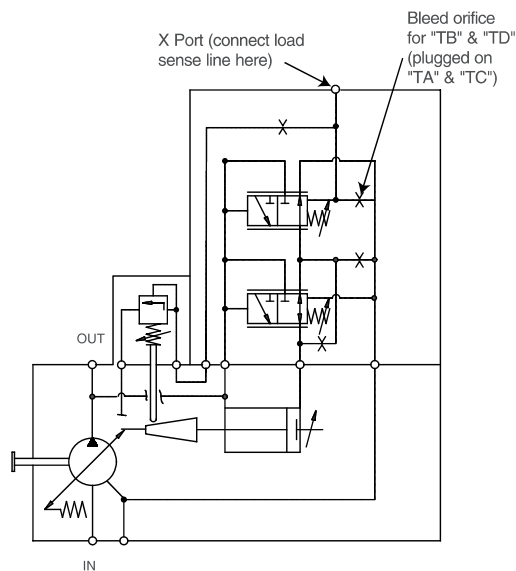
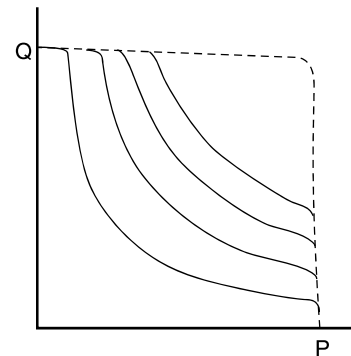

P2 Control Schematic

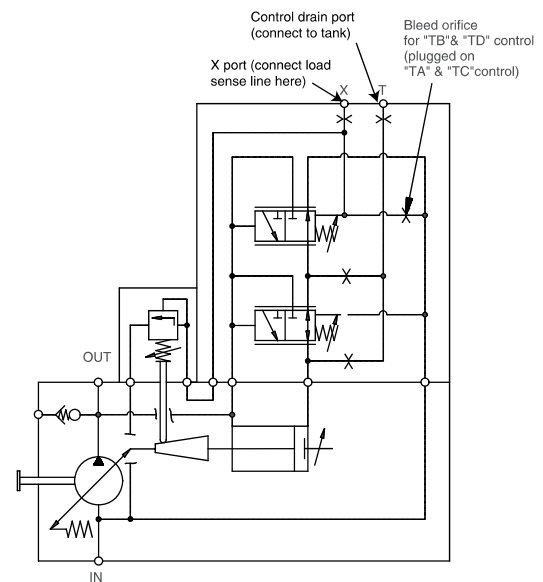

P3 Control Schematic

* See following pages for typical control characteristics

Ripple Chamber

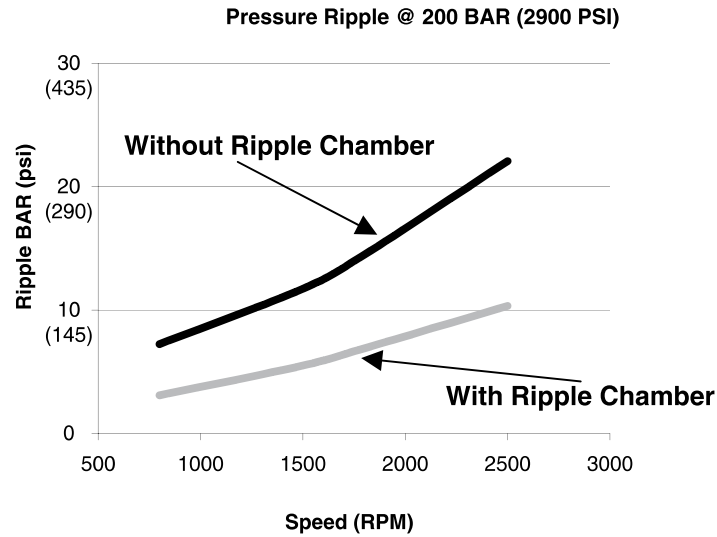

The chart above refers to the “Ripple Chamber” technology that has been engineered into the P2 and P3 series pumps. The ripple chamber reduces pressure pulsation “ripple” at the outlet of the pump. This technology reduces the ripple by 40–60%. This leads to a significant reduction in overall system noise without additional components or cost.

The ripple chamber is standard on all P2 and P3 series side ported pumps.

P2 Performance and Dimension Section

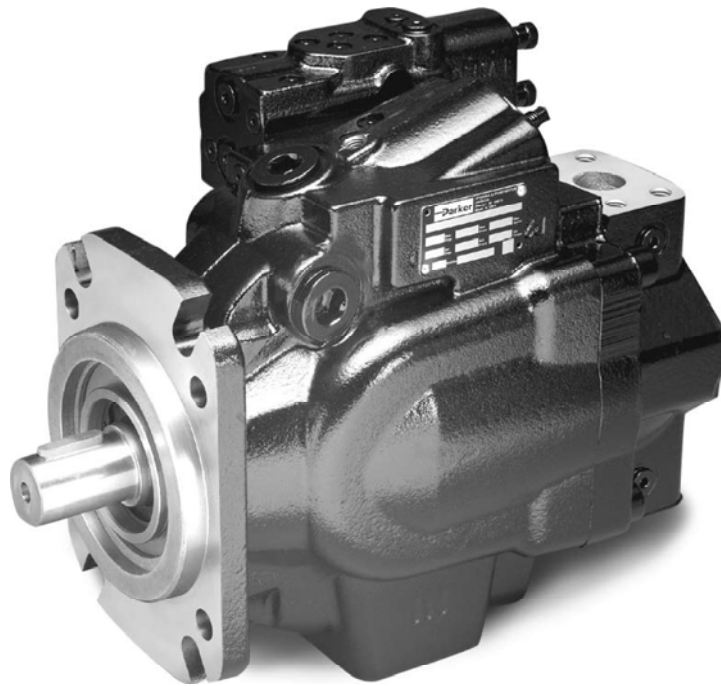

P2 Series Typical Torque Control Characteristics

Fluid: Mineral oil ISO VG 32 @ 40° C

Inlet pressure: 1.0 Bar (14.5 PSI) (Absolute) measured at inlet port.

**P2060 20 - 60% Torque
 1800 RPM**

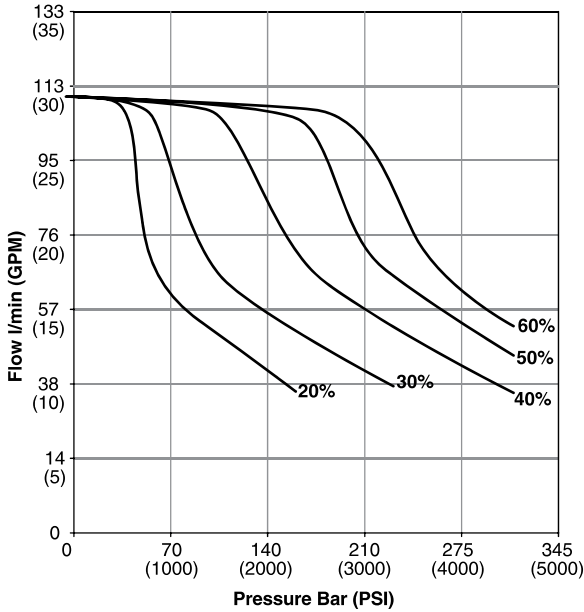

**P2060 50 - 90% Torque
 1800 RPM**

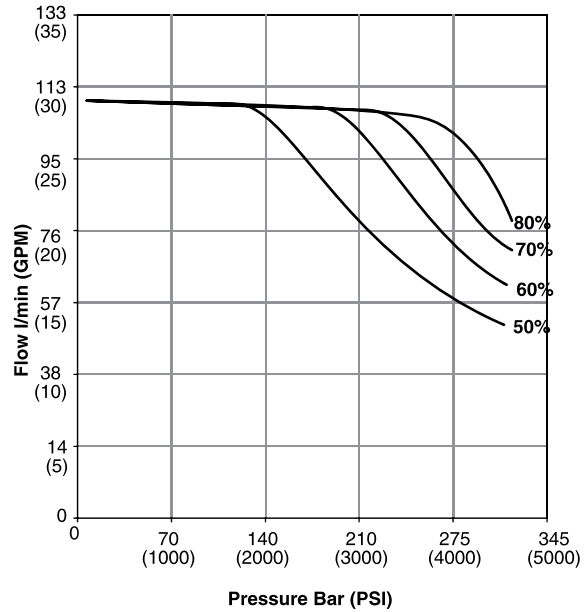

**P2075 20 - 60% Torque
 1800 RPM**

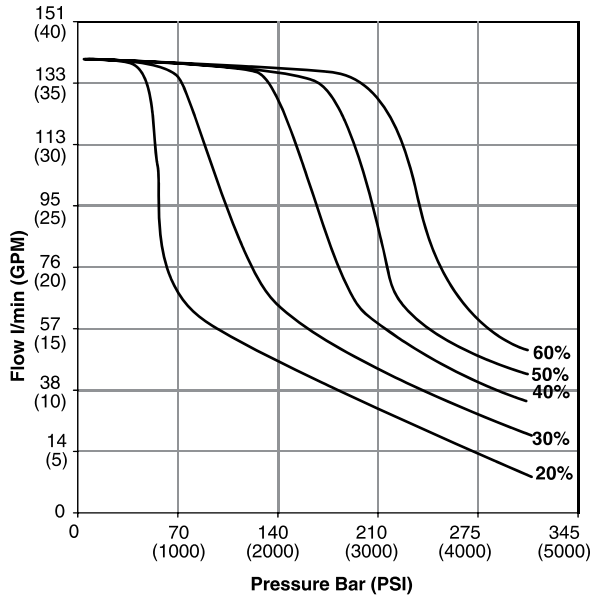

**P2075 50 - 90% Torque
 1800 RPM**

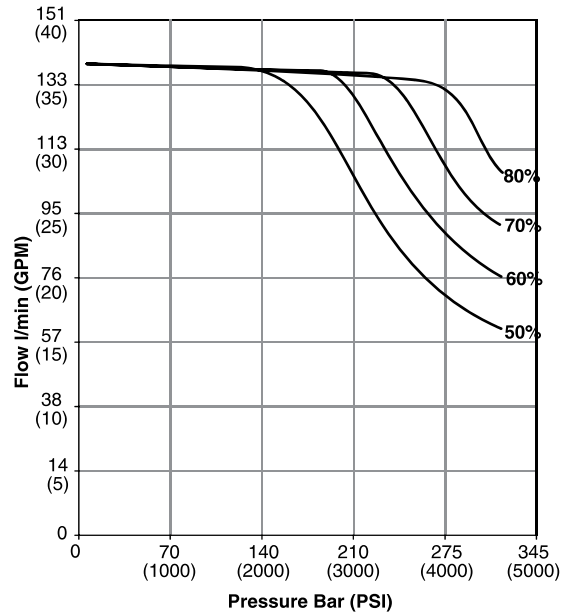

P2 Series Typical Torque Control Characteristics

Fluid: Mineral oil ISO VG 32 @ 40° C

Inlet pressure: 1.0 Bar (14.5 PSI) (Absolute) measured at inlet port.

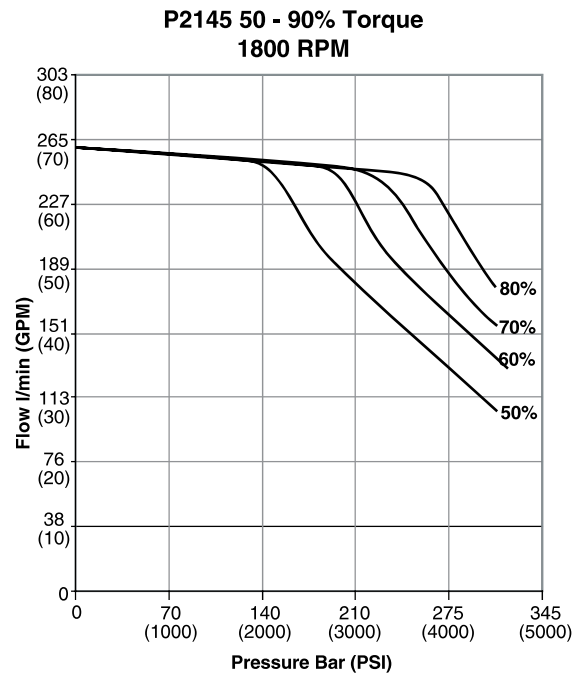
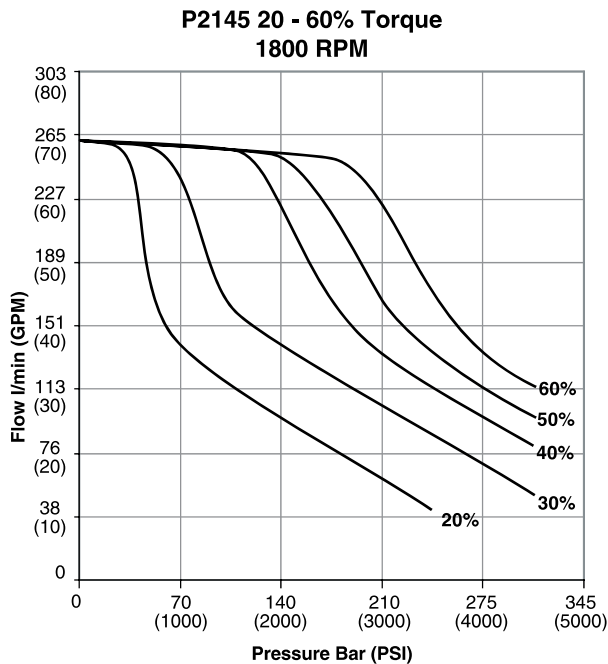
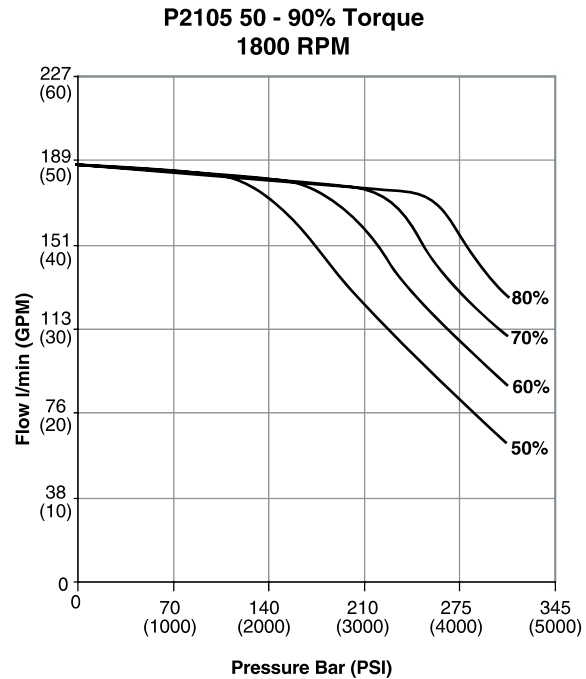
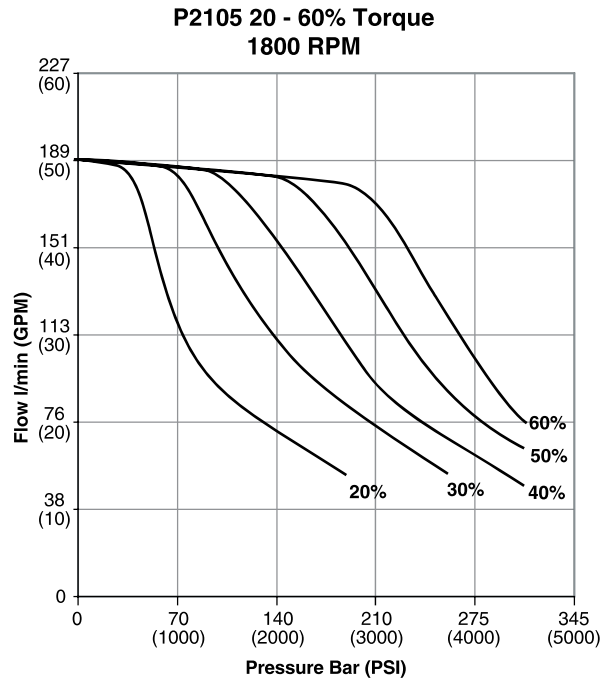

P2 Series Typical Noise Characteristics at Max Displacement

(These are anechoic sound pressure readings.)

Fluid: Mineral oil ISO VG 32 @ 40° C

Inlet pressure: 1.0 Bar (14.5 PSI) (Absolute) measured at inlet port.

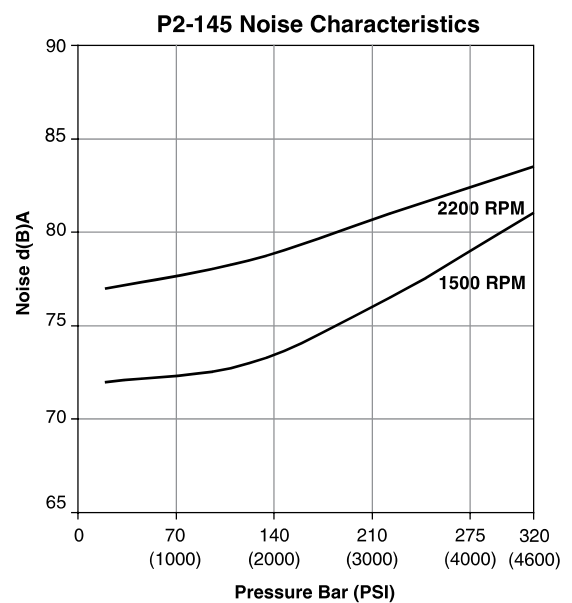
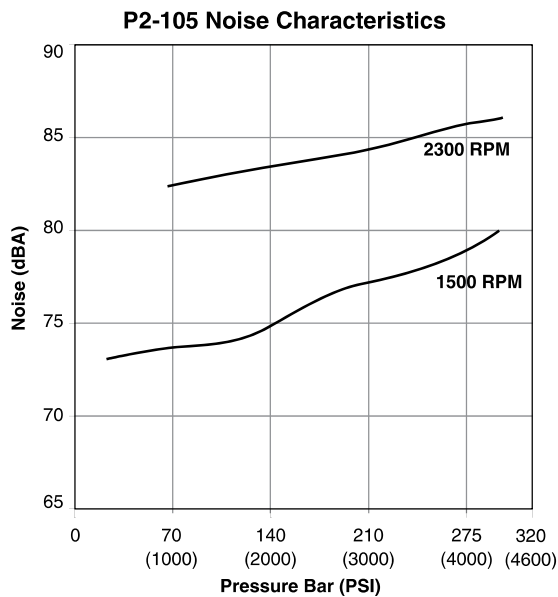
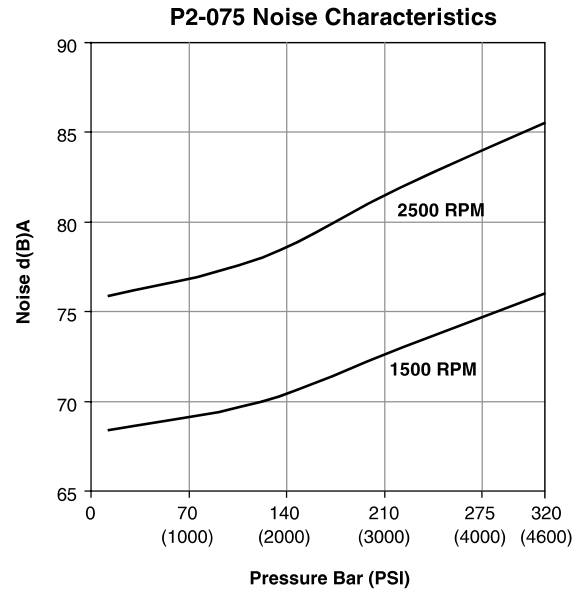
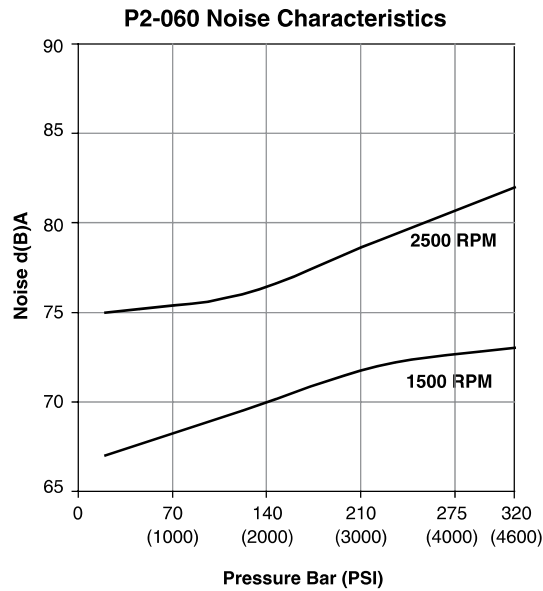

P2 Series Typical Drive Power at Full Displacement

Fluid: Mineral oil ISO VG 32 @ 40° C

Inlet pressure: 1.0 Bar (14.5 PSI) (Absolute) measured at inlet port.

P2060 Input Power - Full Stroke

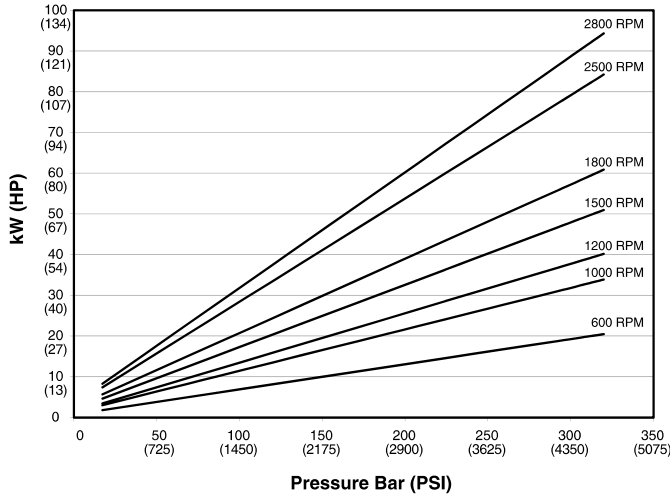

P2075 Input Power - Full Stroke

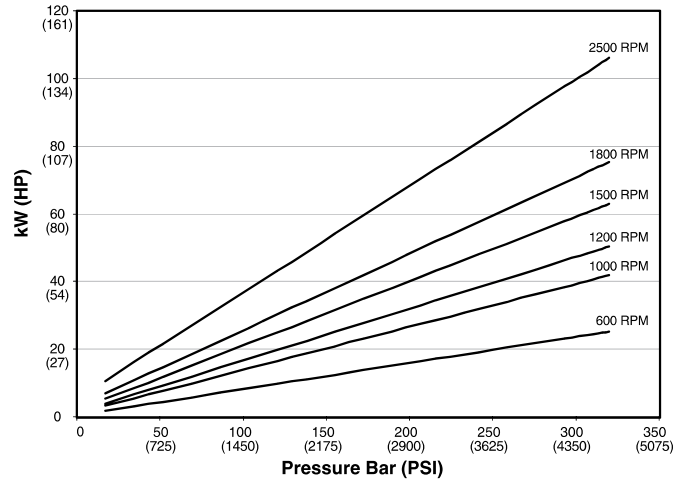

P2105 Input Power - Full Stroke

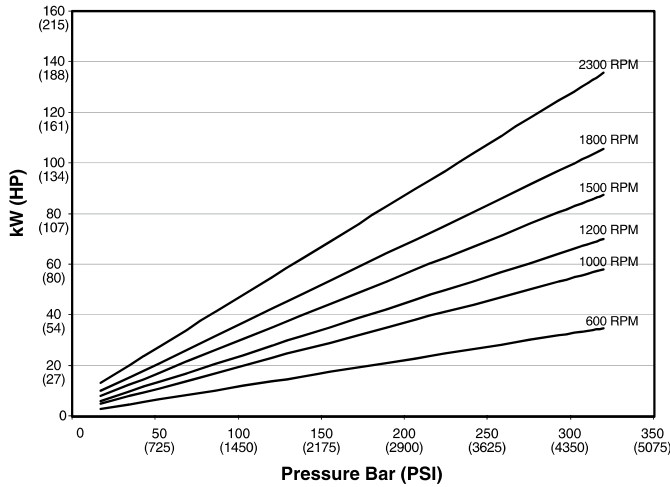

P2145 Input Power - Full Stroke

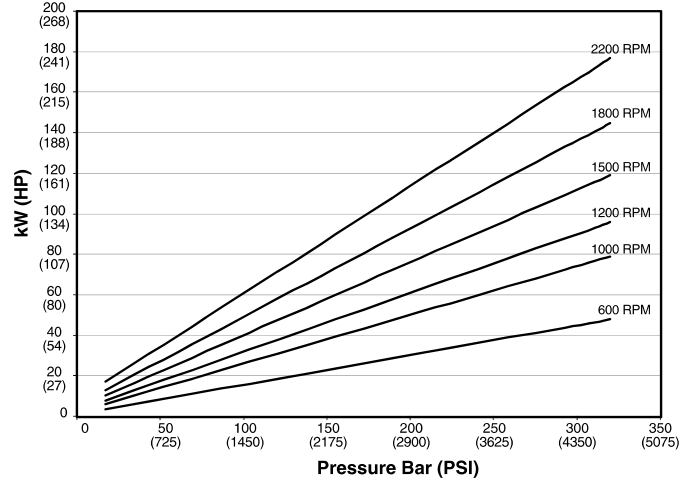

P2 Series Typical Compensated Power

Fluid: Mineral oil ISO VG 32 @ 40° C

Inlet pressure: 1.0 Bar (14.5 PSI) (Absolute) measured at inlet port.

P2060 Input Power - Zero Stroke

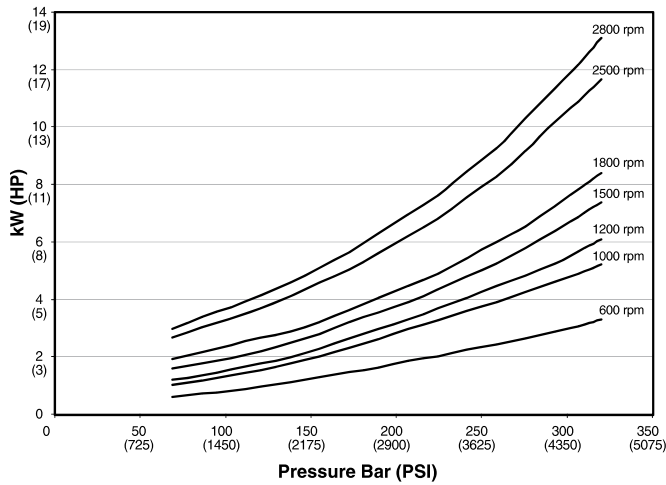

P2075 Input Power - Zero Stroke

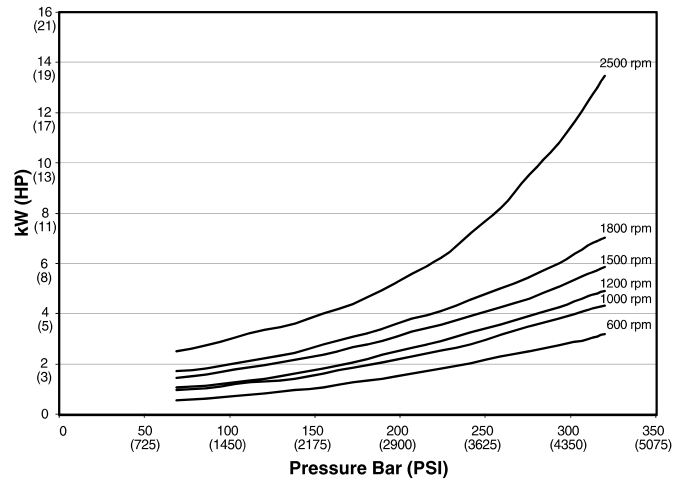

P2105 Input Power - Zero Stroke

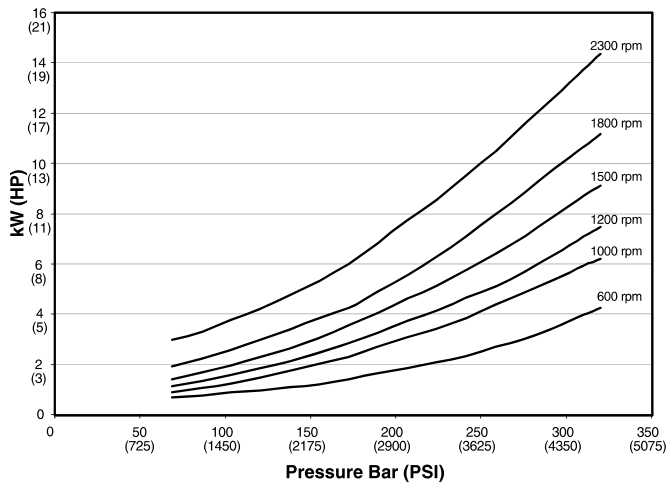

P2145 Input Power - Zero Stroke

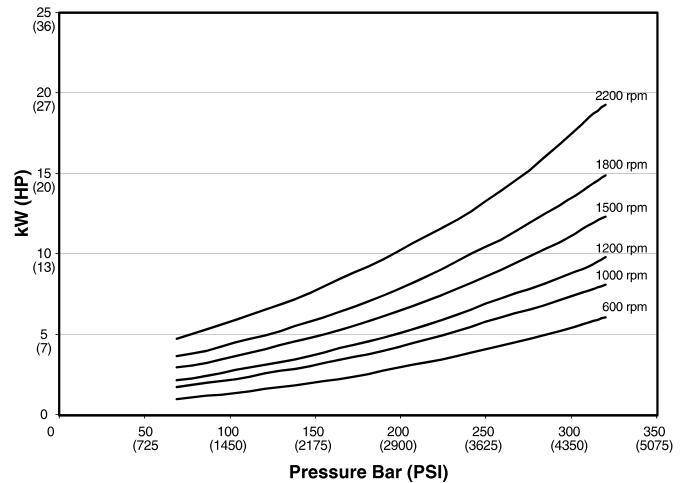

P2 Series Typical Efficiency at Full Displacement @ 1800 RPM

Fluid: Mineral oil ISO VG 32 @ 40° C

Inlet pressure: 1.0 Bar (14.5 PSI) (Absolute) measured at inlet port.

P2060 Efficiency at 1800 RPM

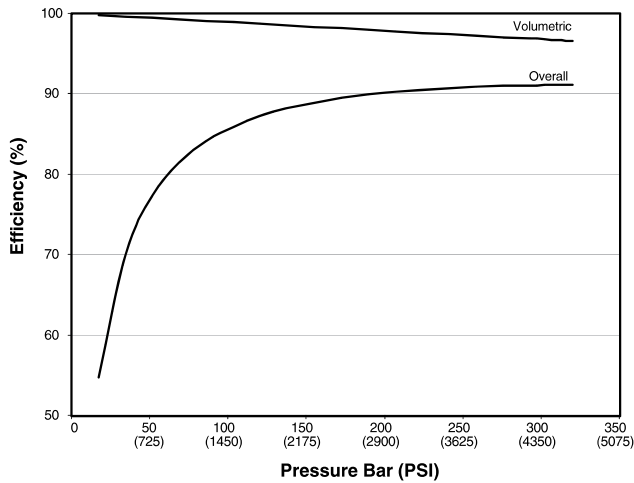

P2075 Efficiency at 1800 RPM

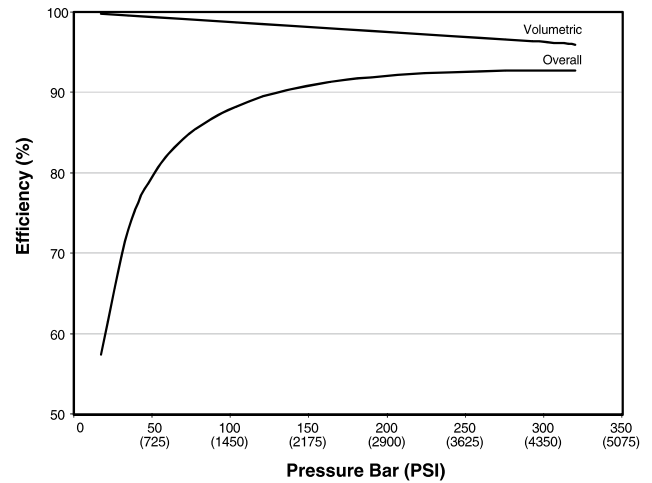

P2105 Efficiency at 1800 RPM

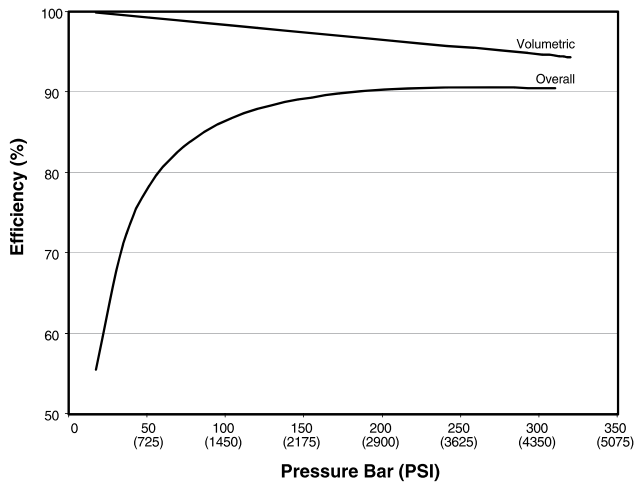

P2145 Efficiency at 1800 RPM

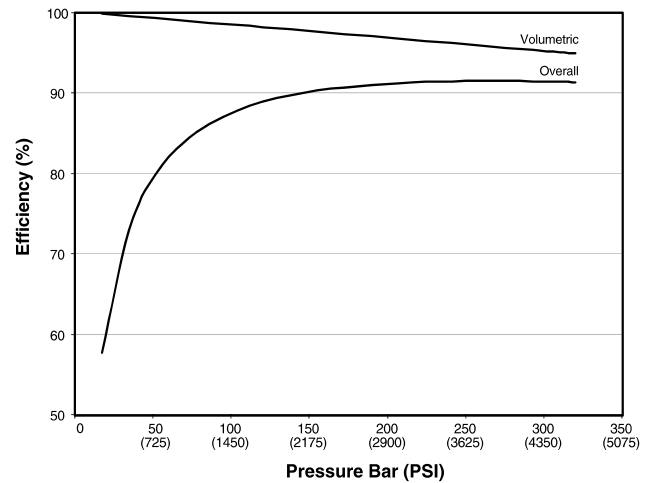

P2 Series Typical Flow vs. Pressure

Fluid: Mineral oil ISO VG 32 @ 40° C

Inlet pressure: 1.0 Bar (14.5 PSI) (Absolute) measured at inlet port.

P2060 Outlet Flow - Full Stroke

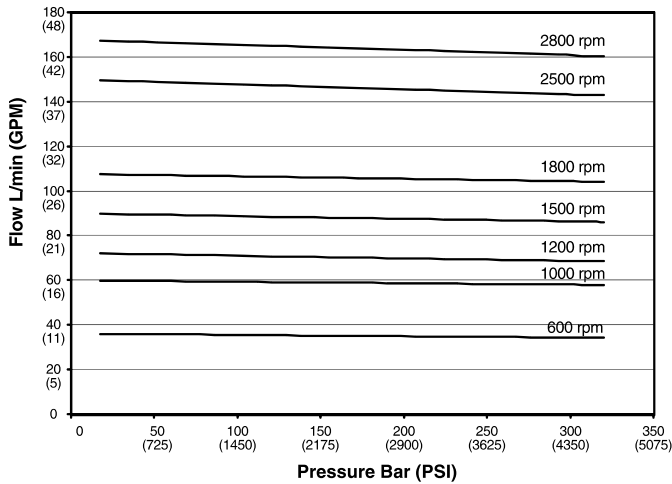

P2075 Outlet Flow - Full Stroke

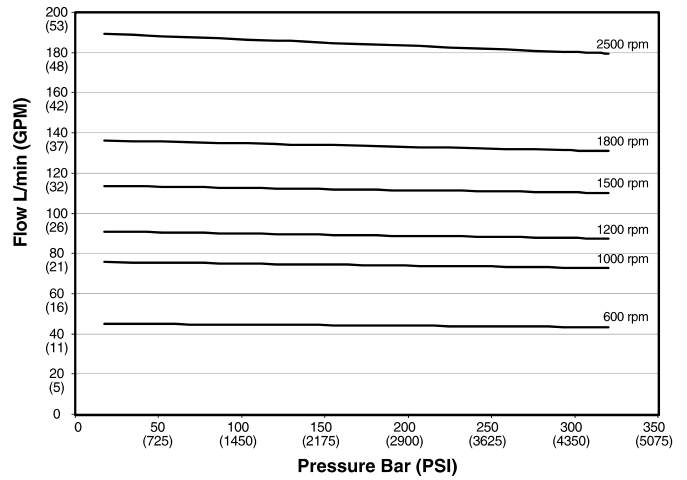

P2105 Outlet Flow - Full Stroke

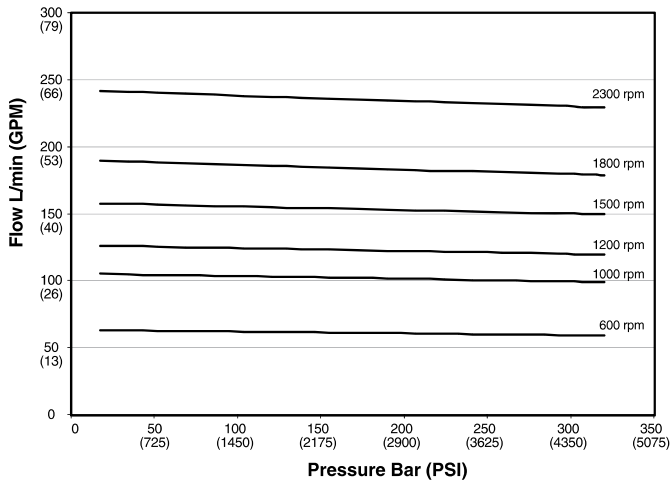

P2145 Outlet Flow - Full Stroke

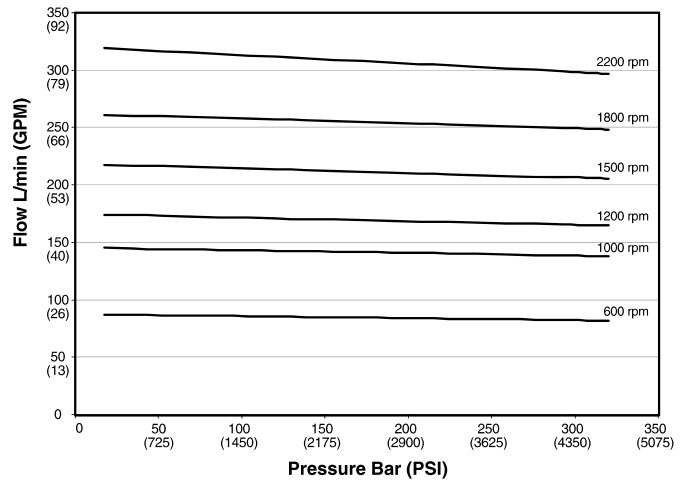

P2 Series Typical Compensated Case Drain Flow

Fluid: Mineral oil ISO VG 32 @ 40° C

Inlet pressure: 1.0 Bar (14.5 PSI) (Absolute) measured at inlet port.

P2060 Drain Flow at Zero Stroke

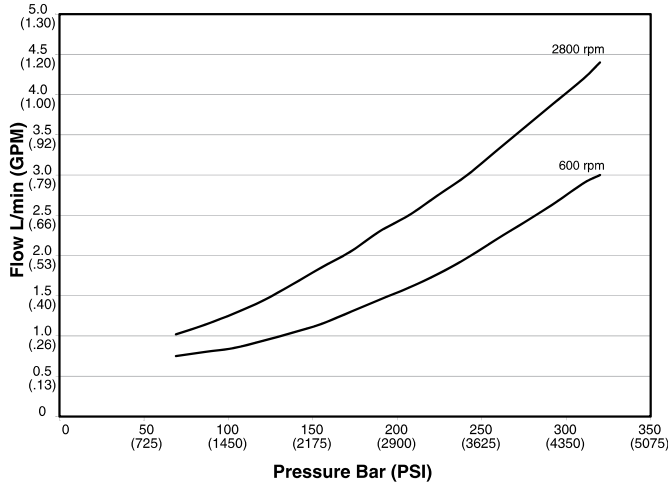

P2075 Drain Flow at Zero Stroke

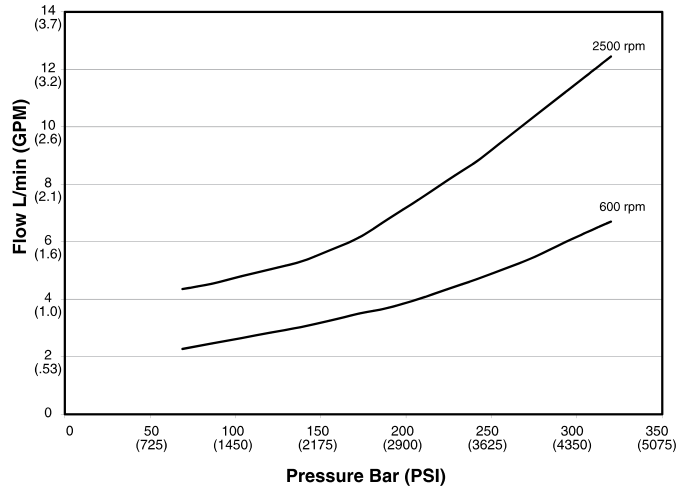

P2105 Drain Flow at Zero Stroke

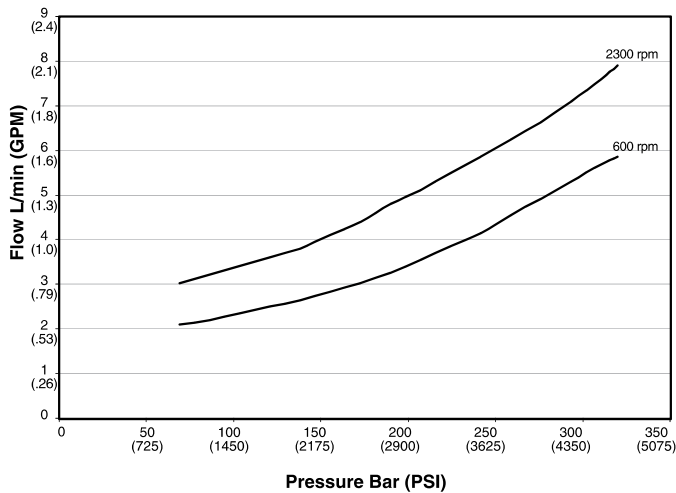

P2145 Drain Flow at Zero Stroke

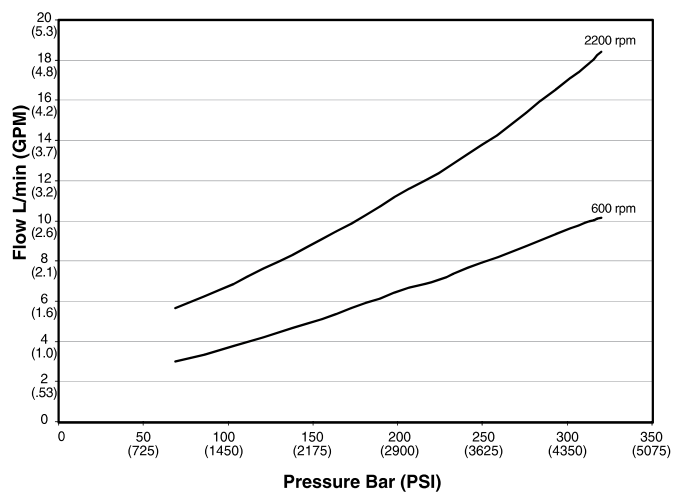

P2 Series Typical Inlet Characteristics vs. Speed at various percentage displacements

Fluid: Mineral oil ISO VG 32 @ 40° C

Inlet pressure: 1.0 Bar (14.5 PSI) measured at inlet port.

P2060 Inlet Characteristics

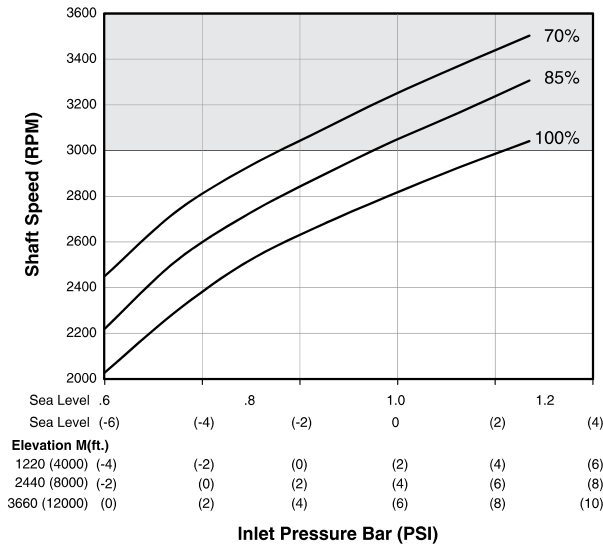

P2075 Inlet Characteristics

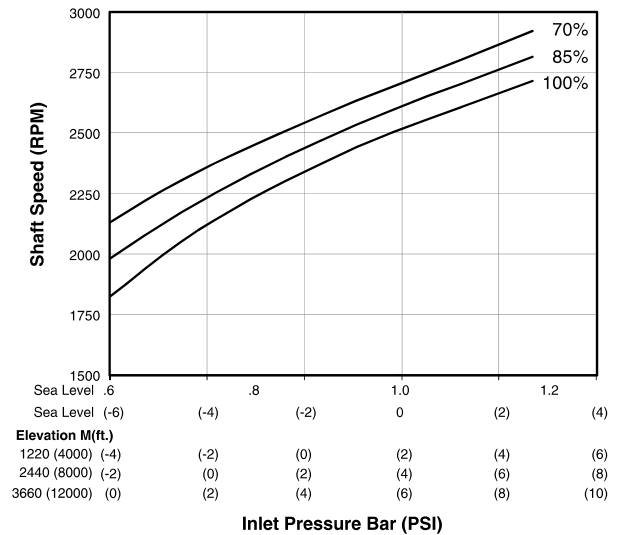

P2105 Inlet Characteristics

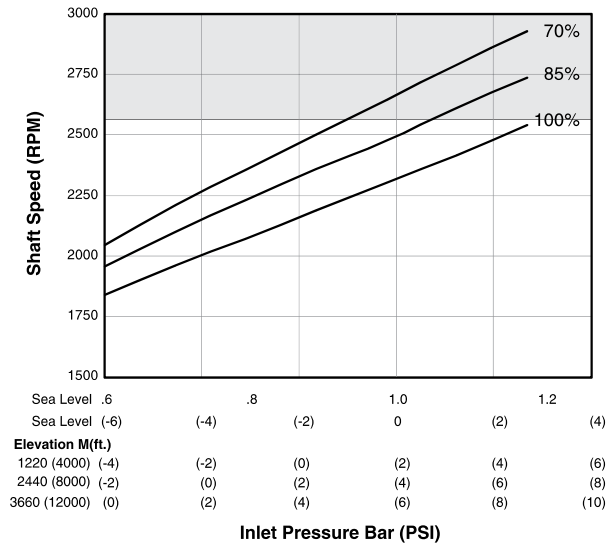

P2145 Inlet Characteristics

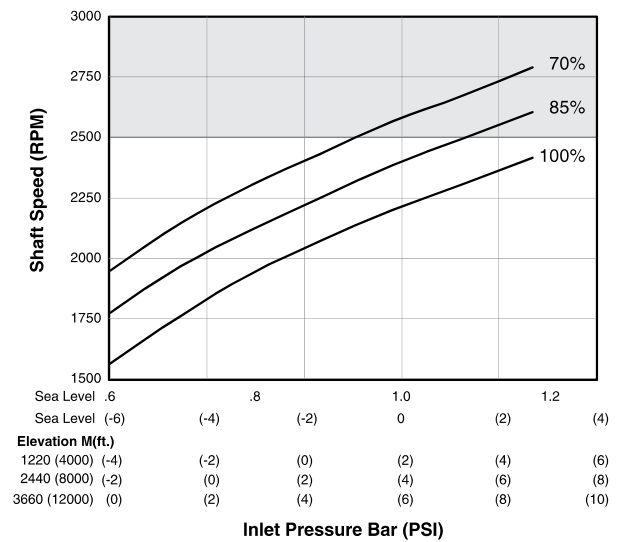

 For operation at these speeds, please consult factory for approval.

Pump Installation - P2-060 Mounting Flange (side port)

Port Options	Drain Port	Inlet Gauge Port Outlet Gauge Port Signal Port
"A" Side - UNC	SAE-10 Straight Thread O-ring Port 7/8-14 UN Thread	SAE-4 Straight Thread O-ring Port 7/16-20 UN Thread
"B" Side - Metric	ISO 6149 Straight Thread O-ring Port M22 x 1.5 Thread	ISO 6149 Straight Thread O-ring Port M12 x 1.5 Thread

SAE B 2-BOLT MOUNTING FLANGE - DIAGONAL MOUNT

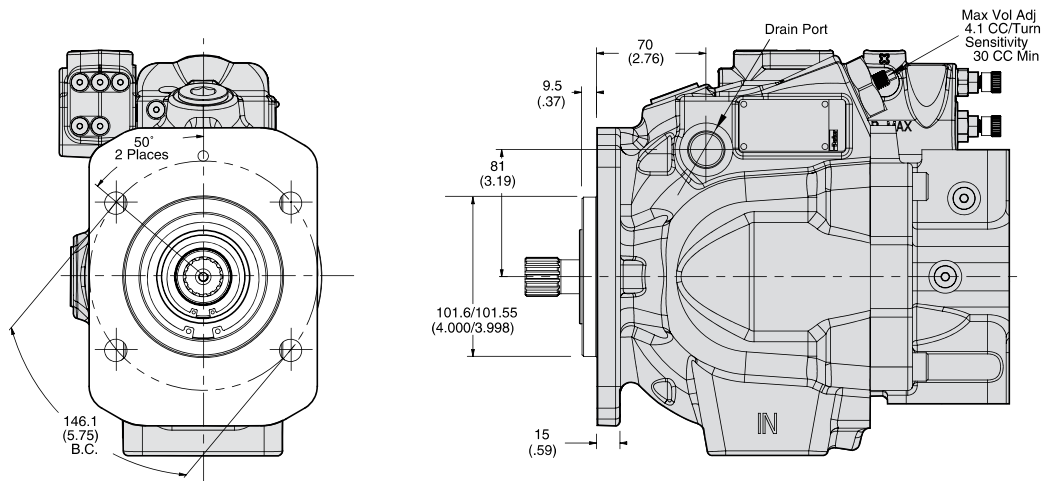

SAE C 4-BOLT MOUNTING FLANGE

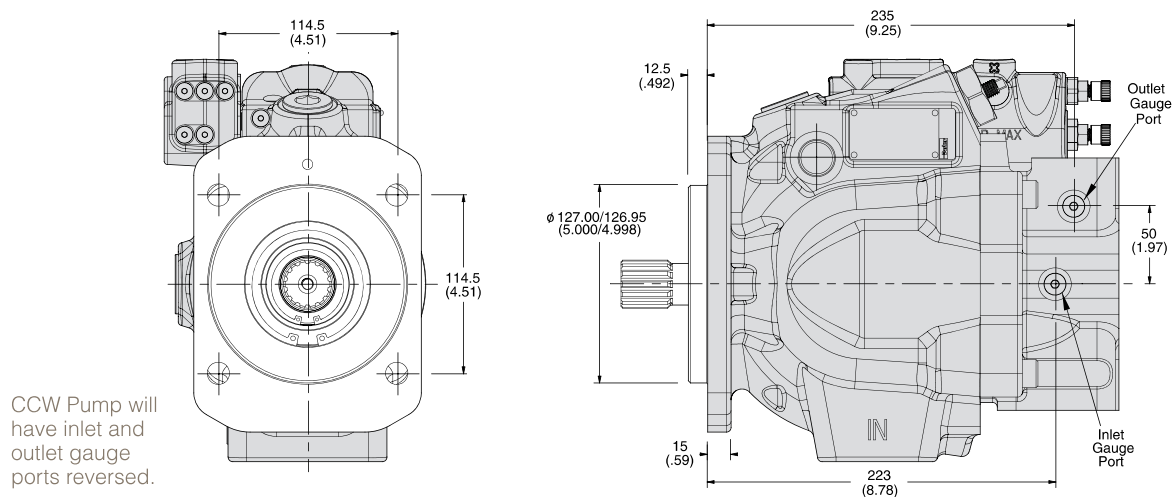

Pump Installation - P2-060 Side Port

Port Options	Drain Port	Inlet Port	Outlet Port	Inlet Gauge Port Outlet Gauge Port Signal Port
"A" Side - UNC	SAE-12 Straight Thread O-ring Port 1-1/16-12 Thread	1/2-13 UN	7/16-14 UN	SAE-4 Straight Thread O-ring Port 7/16-20 UN Thread
"B" Side - Metric	ISO 6149 Straight Thread O-ring Port M27 x 2 Thread	M12 x 1.75	M12 x 1.75	ISO 6149 Straight Thread O-ring Port M12 x 1.5 Thread

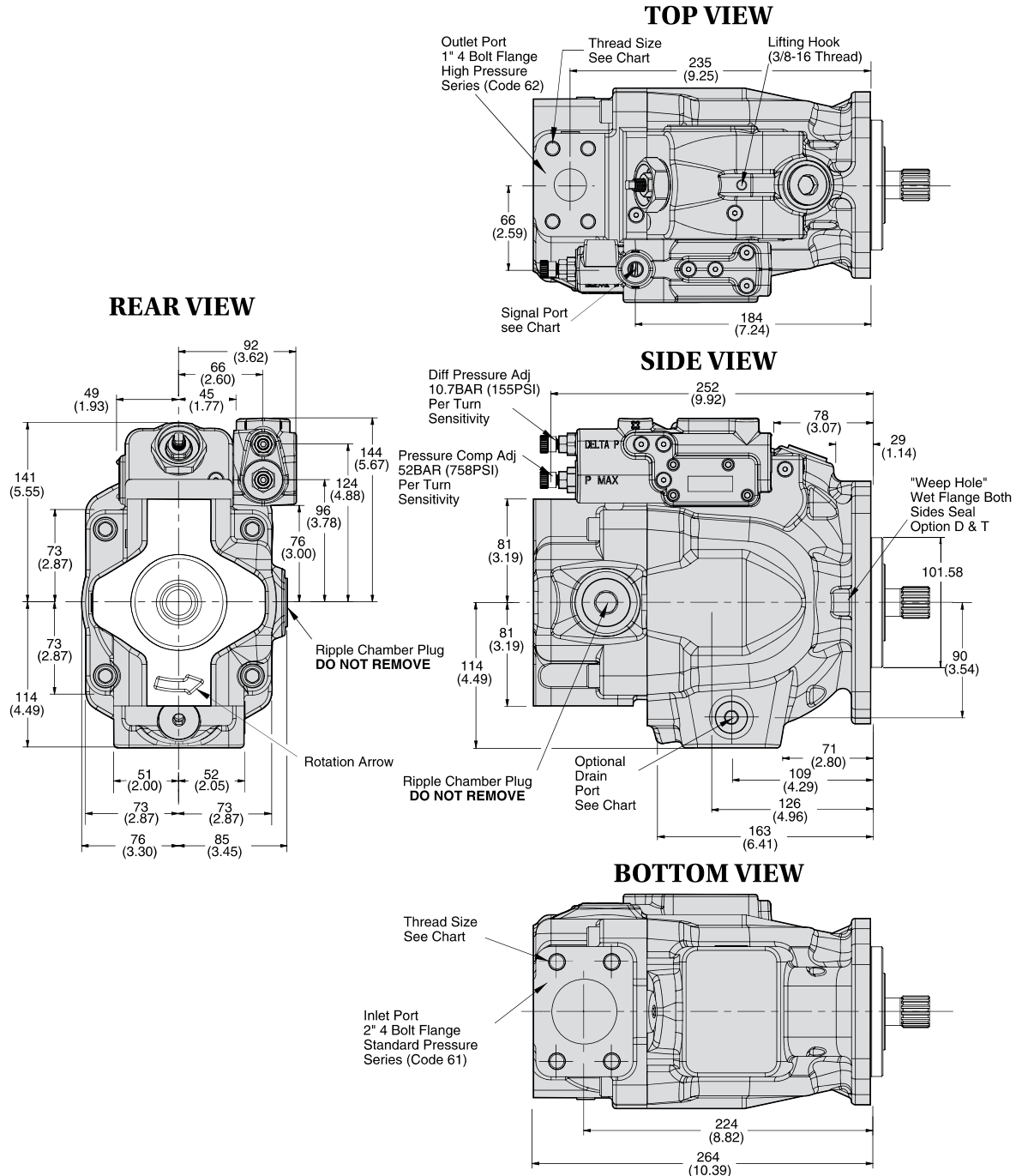

Pump Installation - P2-060 Mounting Flange (rear port)

SAE B 2-BOLT MOUNTING FLANGE - DIAGONAL MOUNT

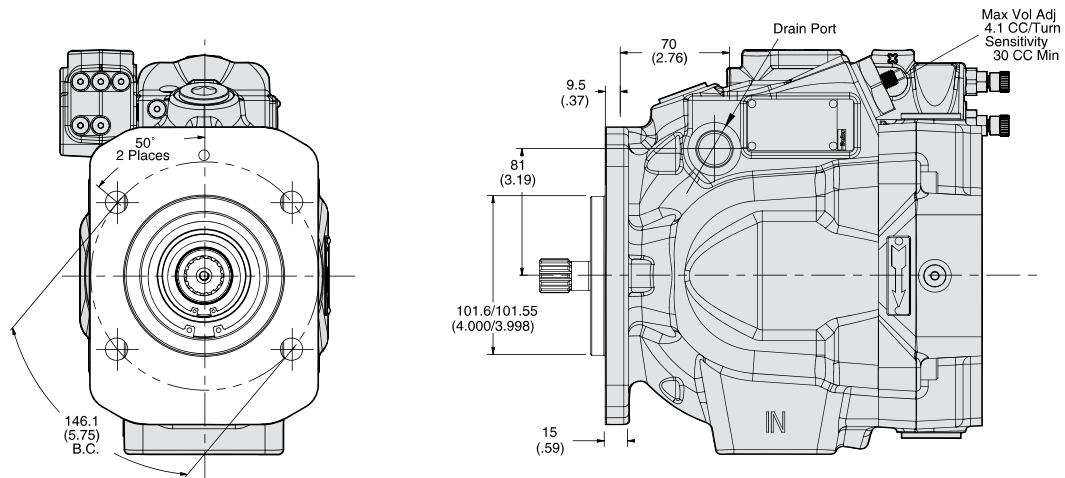

SAE C 4-BOLT MOUNTING FLANGE

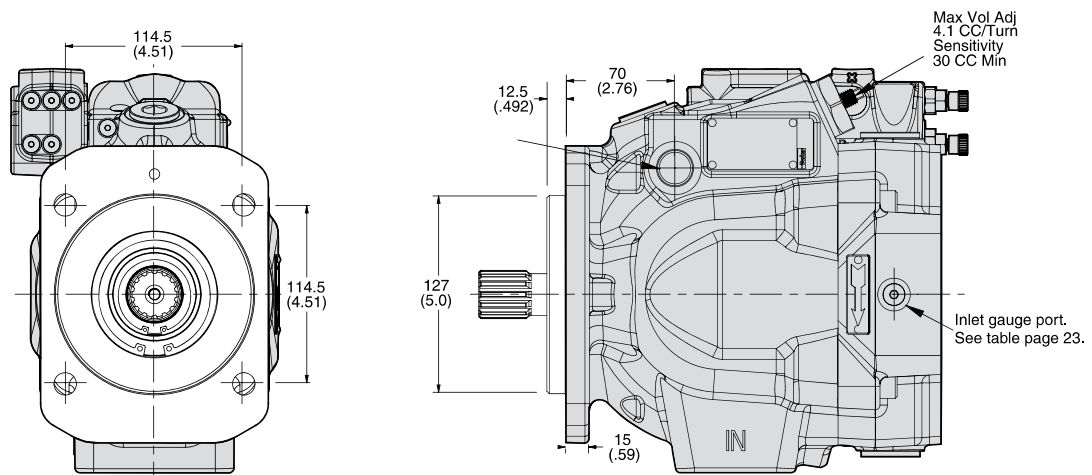

CCW Pump will have inlet and outlet gauge ports reversed. Does not include Ripple Chamber.

Pump Installation - P2-060 Rear Port

Port Options	Drain Port	Inlet Port	Outlet Port	Inlet Gauge Port Outlet Gauge Port Signal Port
"G" Rear - UNC	SAE-12 Straight Thread O-ring Port 1-1/16-12 Thread	1/2-13 UN	7/16-14 UN	SAE-4 Straight Thread O-ring Port 7/16-20 UN Thread
"H" Rear - Metric	ISO 6149 Straight Thread O-ring Port M27 x 2 Thread	M12 x 1.75	M12 x 1.75	ISO 6149 Straight Thread O-ring Port M12 x 1.5 Thread

TOP VIEW

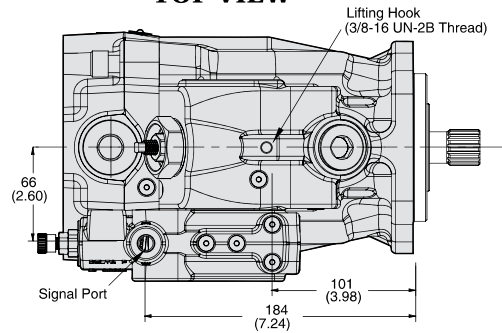

REAR VIEW

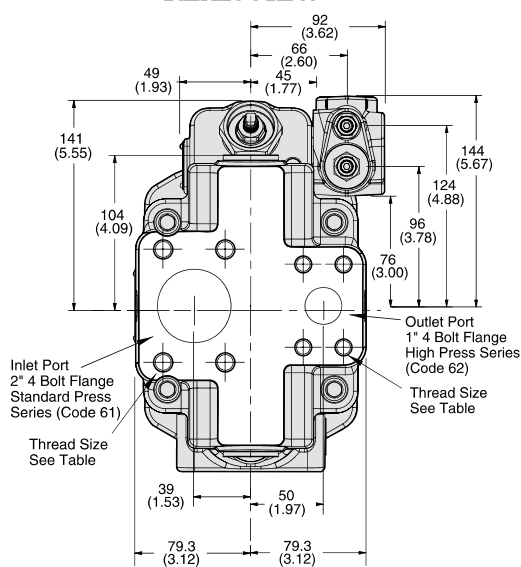

SIDE VIEW

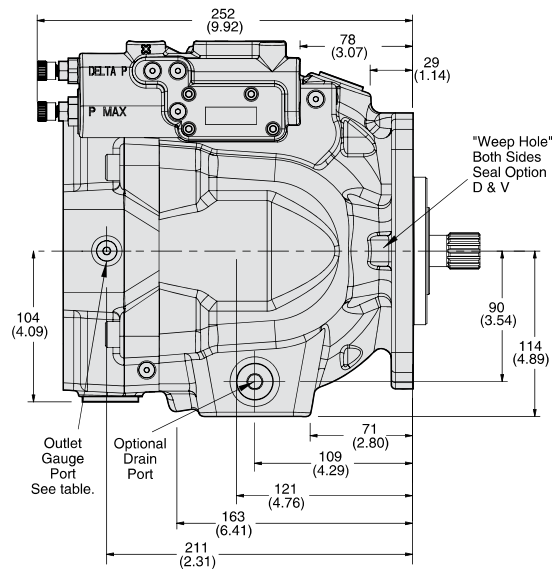

BOTTOM VIEW

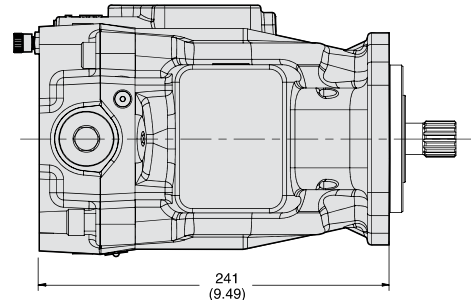

1. Pump shown is a clockwise rotation P2-060 series axial piston pump with load sense and maximum pressure.
2. CCW rotation pump will have inlet and outlet ports reversed.

Pump Installation - P2-060 Thru-Shaft Option

Thru-Shaft Option	A	B	C	D	E	F UNC	F Metric	G UNC	G Metric	Pump Weight
A1	264 (10.4)	82.625/ 82.575 (3.252/ 3.250)	106.38 (4.19)	N/A	SAE-A Spline 9 Tooth 16/32 Pitch	3/8-16 UNC-2B THD	M10 x 1.5 THD	N/A	N/A	36.2 kg (80 lbs)
B1	297 (11.7)	101.676/ 101.625 (4.002/ 4.000)	146.05 (5.75)	N/A	SAE-B Spline 13 Tooth 16/32 Pitch	1/2-13 UNC-2B THD	M12 x 1.75 THD	N/A	N/A	38.9 kg (86 lbs)
B2	297 (11.7)	101.676/ 101.625 (4.002/ 4.000)	146.05 (5.75)	N/A	SAE-BB Spline 15 Tooth 16/32 Pitch	1/2-13 UNC-2B THD	M12 x 1.75 THD	N/A	N/A	38.9 kg (86 lbs)
C1 C3	299 (11.8)	127.076/ 127.025 (5.002/ 5.000)	180.98 (7.125)	114.5 (4.58)	SAE-C Spline 14 Tooth 12/24 Pitch	5/8-11 UNC-2B THD	M16 x 2 THD	1/2-13 UNC-2B THD	M12 x 1.75 THD	40.2 kg (89 lbs)

A1 CONFIGURATION

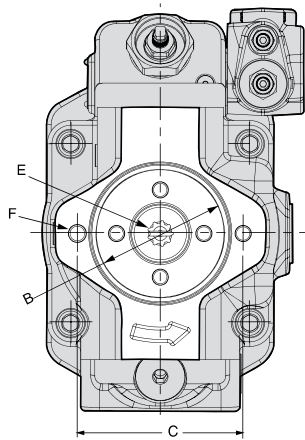

B1 & B2 CONFIGURATION

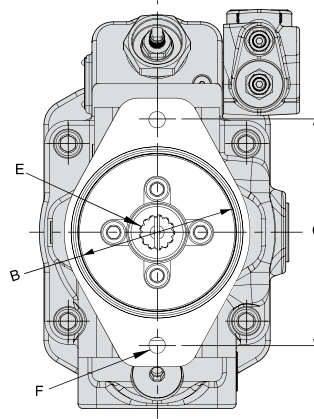

C1 & C3 CONFIGURATION

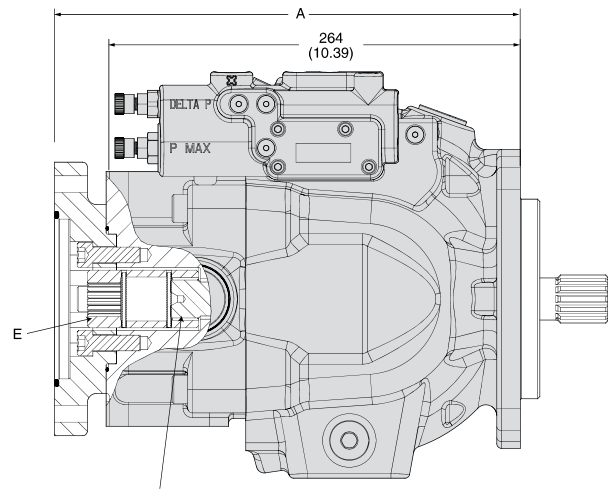
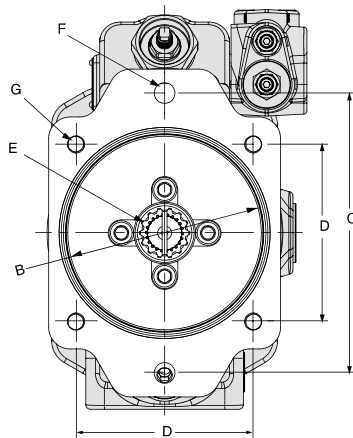

Max Thru-Drive Torque is 336 Nm (2980 lb in)

Pump Installation - P2-075 Mounting Flange

Port Options	Drain Port	Inlet Gauge Port Outlet Gauge Port
"A" Side - UNC	SAE-12 Straight Thread O-ring Port 1-1/16-12 UN Thread	SAE-4 Straight Thread O-ring Port 7/16-20 UN Thread
"B" Side - Metric	ISO 6149 Straight Thread O-ring Port M27 x 2 Thread	ISO 6149 Straight Thread O-ring Port M12 x 1.5 Thread

FLANGE MOUNTING DIMENSIONS - SIDE PORTED PUMP

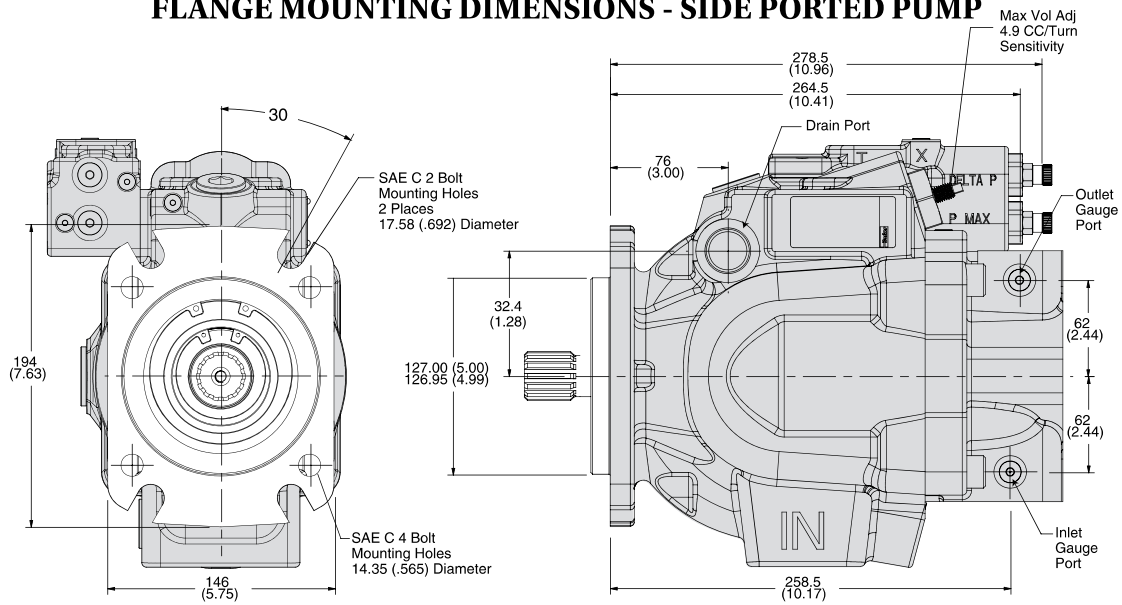

FLANGE MOUNTING DIMENSIONS - REAR PORTED PUMP

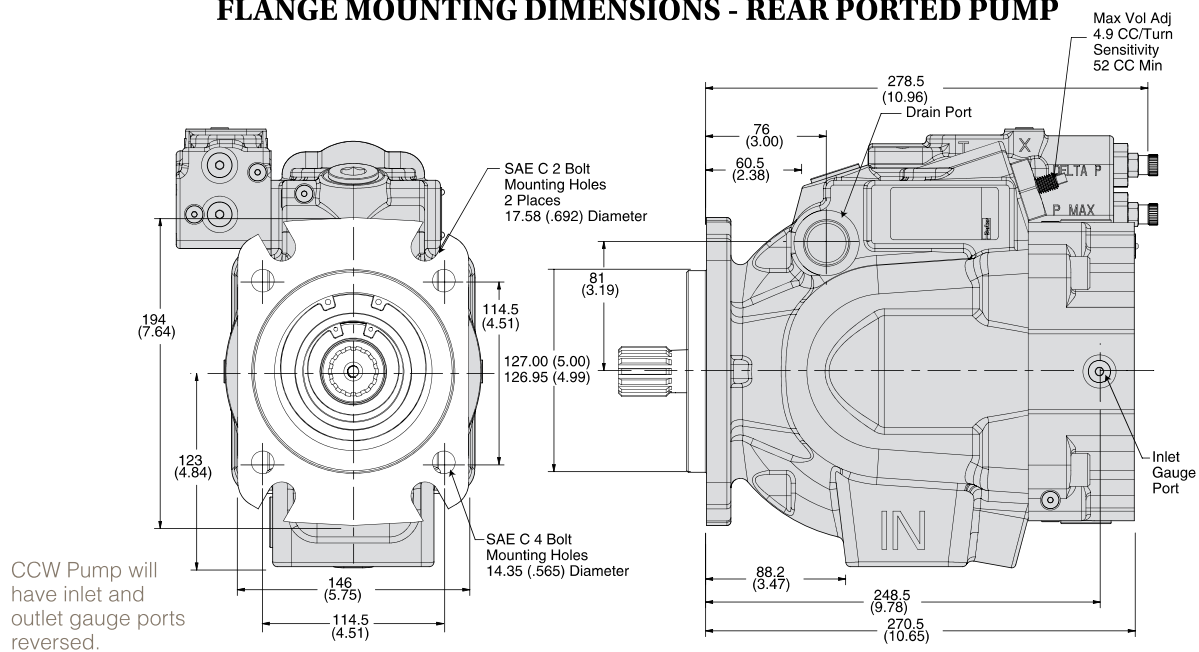

Pump Installation - P2-075 Side Port

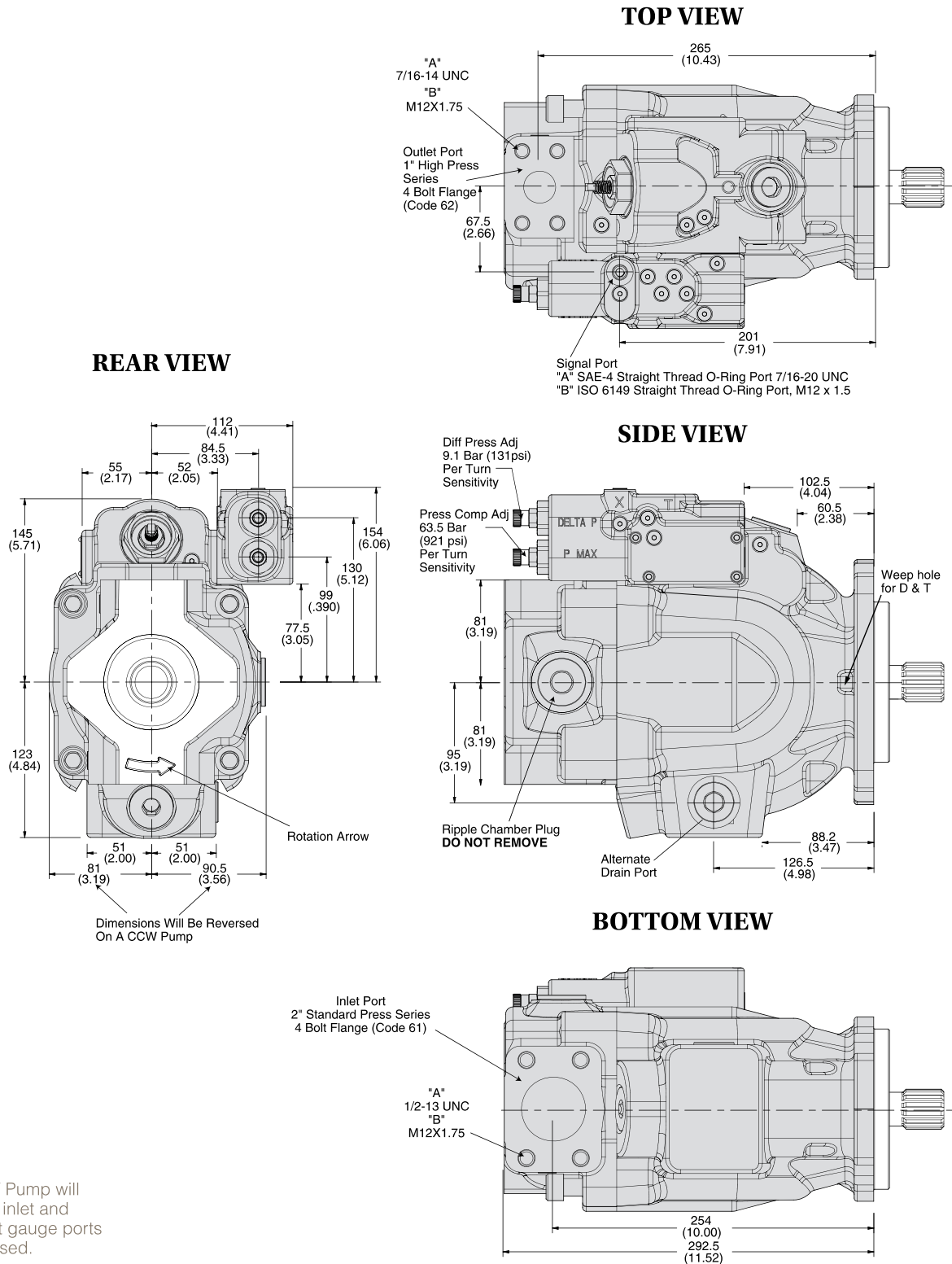

CCW Pump will have inlet and outlet gauge ports reversed.

Pump Installation - P2-075 Rear Port

Port Options	Drain Port	Inlet Port	Outlet Port	Inlet Gauge Port Outlet Gauge Port Signal Port
"G" Rear - UNC	SAE-12 Straight Thread O-ring Port 1-1/16-12 Thread	1/2-13 UN	7/16-14 UN	SAE-4 Straight Thread O-ring Port 7/16-20 UN Thread
"H" Rear - Metric	ISO 6149 Straight Thread O-ring Port M27 x 2 Thread	M12 x 1.75	M12 x 1.75	ISO 6149 Straight Thread O-ring Port M12 x 1.5 Thread

TOP VIEW

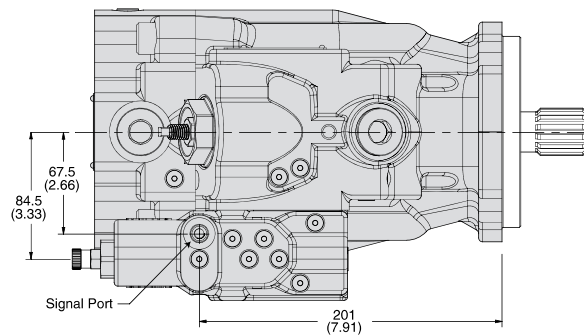

REAR VIEW

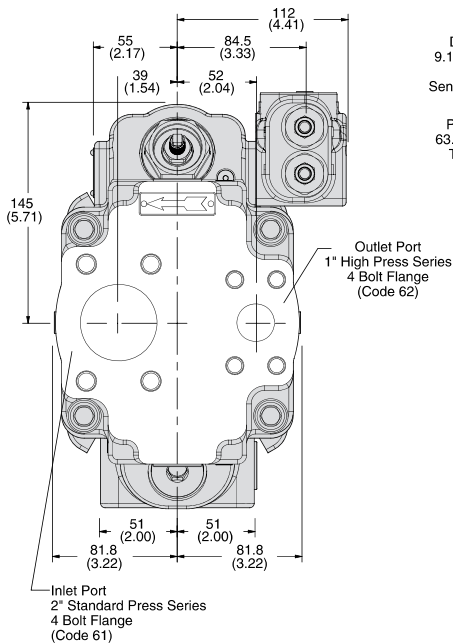

SIDE VIEW

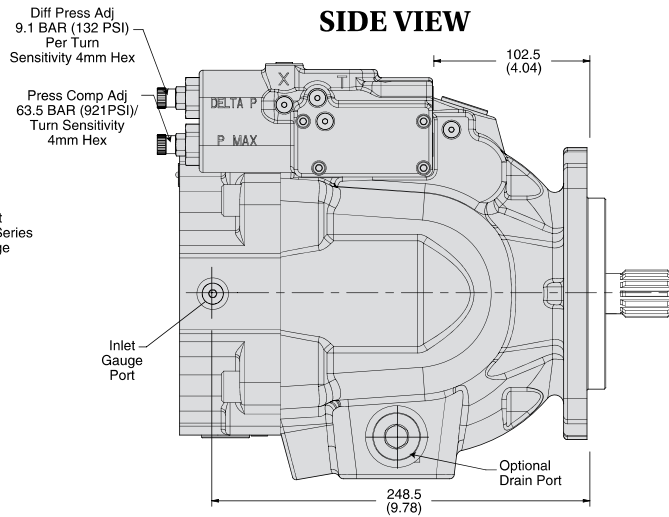

BOTTOM VIEW

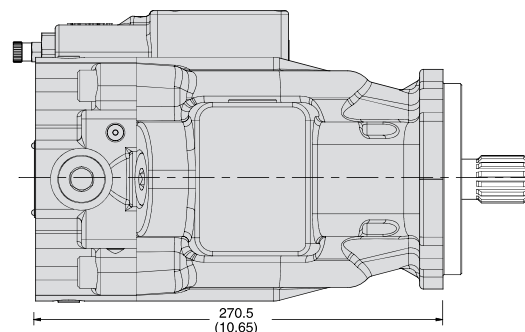

1. Pump shown is a clockwise rotation P2-075 series axial piston pump with load sense and maximum pressure.
2. CCW rotation pump will have inlet and outlet ports reversed.

Pump Installation - P2-075 Thru-Shaft Option

Thru-Shaft Option	A	B	C	D	E	F UNC	F Metric	G UNC	G Metric	Pump Weight
A1	292.5 (10.4)	82.625/ 82.575 (3.252/ 3.250)	106.38 (4.19)	N/A	SAE-A Spline 9 Tooth 16/32 Pitch	3/8-16 UNC-2B THD	M10 x 1.5 THD	N/A	N/A	44 kg (97 lbs)
B1	325.5 (11.7)	101.676/ 101.625 (4.002/ 4.000)	146.05 (5.75)	N/A	SAE-B Spline 13 Tooth 16/32 Pitch	1/2-13 UNC-2B THD	M12 x 1.75 THD	N/A	N/A	46.5 kg (102.5 lbs)
B2	325.5 (11.7)	101.676/ 101.625 (4.002/ 4.000)	146.05 (5.75)	N/A	SAE-BB Spline 15 Tooth 16/32 Pitch	1/2-13 UNC-2B THD	M12 x 1.75 THD	N/A	N/A	46.5 kg (102.5 lbs)
C1 C3	299 (11.8)	127.076/ 127.025 (5.002/ 5.000)	180.98 (7.125)	114.5 (4.58)	SAE-C Spline 14 Tooth 12/24 Pitch	5/8-11 UNC-2B THD	M16 x 2 THD	1/2-13 UNC-2B THD	M12 x 1.75 THD	48 kg (105.9 lbs)

A1 CONFIGURATION

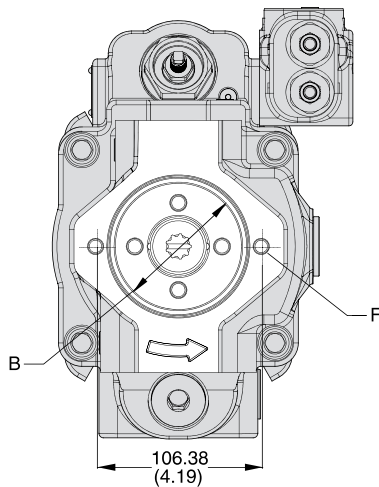

B1 & B2 CONFIGURATION

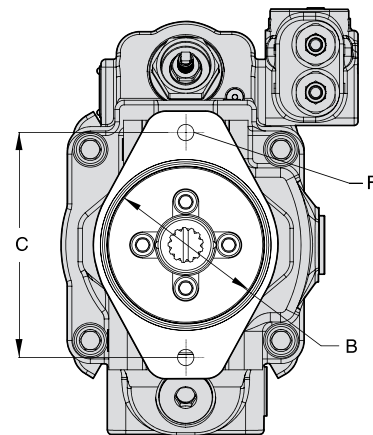

**Pumps will be assembled with flange adapters as shown.
 Options B1, B2, C1 and C3 can be rotated 90°.**

C1 & C3 CONFIGURATION

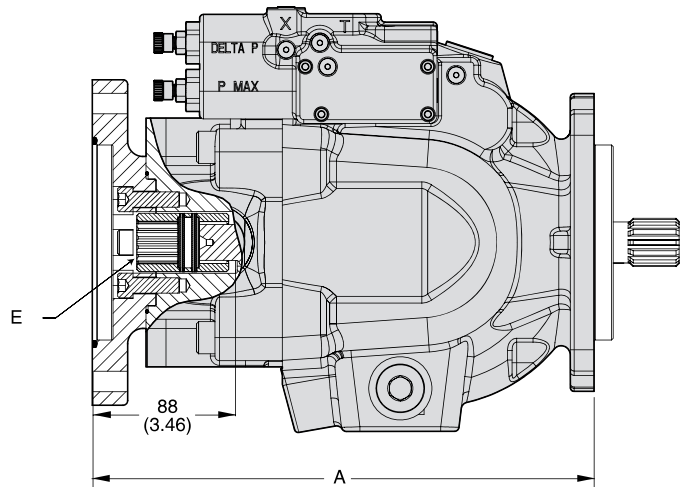
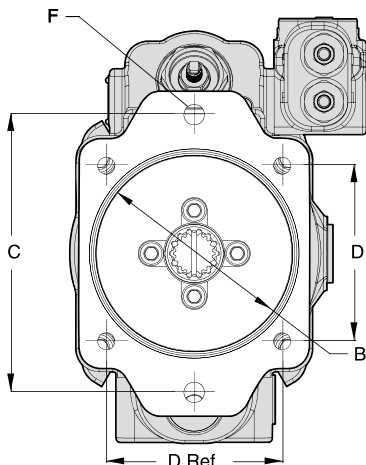

Max Thru-Drive Torque is 336 Nm (2973 lb in)

Pump Installation - P2-105 Mounting Flange

Port Options	Drain Port	Inlet Gauge Port Outlet Gauge Port
"A" Side - UNC	SAE-12 Straight Thread O-ring Port 1-1/16-12 UN-2B	SAE-4 Straight Thread O-ring Port 7/16-20 UN Thread
"B" Side - Metric	ISO 6149 Straight Thread O-ring Port M27 x 2 Thread	ISO 6149 Straight Thread O-ring Port M12 x 1.5 Thread

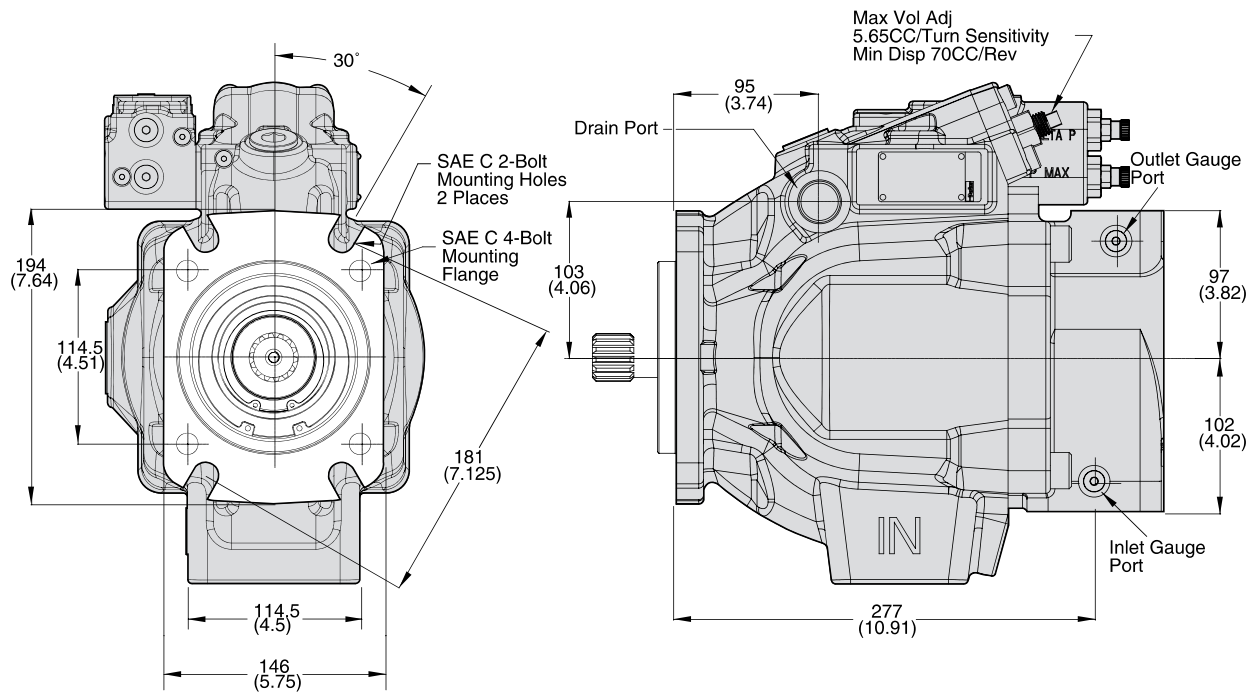

CCW Pump will have inlet and outlet gauge ports reversed.

Pump Installation - P2-105 Side Port

Port Options	Drain Port	Inlet Port	Outlet Port	Inlet Gauge Port Outlet Gauge Port Signal Port
"A" Side - UNC	SAE-12 Straight Thread O-ring Port 1-1/16-12 UN-2B	1/2-13 UN	1/2-13 UN	SAE-4 Straight Thread O-ring Port 7/16-20 UN Thread
"B" Side - Metric	ISO 6149 Straight Thread O-ring Port M27 x 2 Thread	M12 x 1.75	M12 x 1.75	ISO 6149 Straight Thread O-ring Port M12 x 1.5 Thread

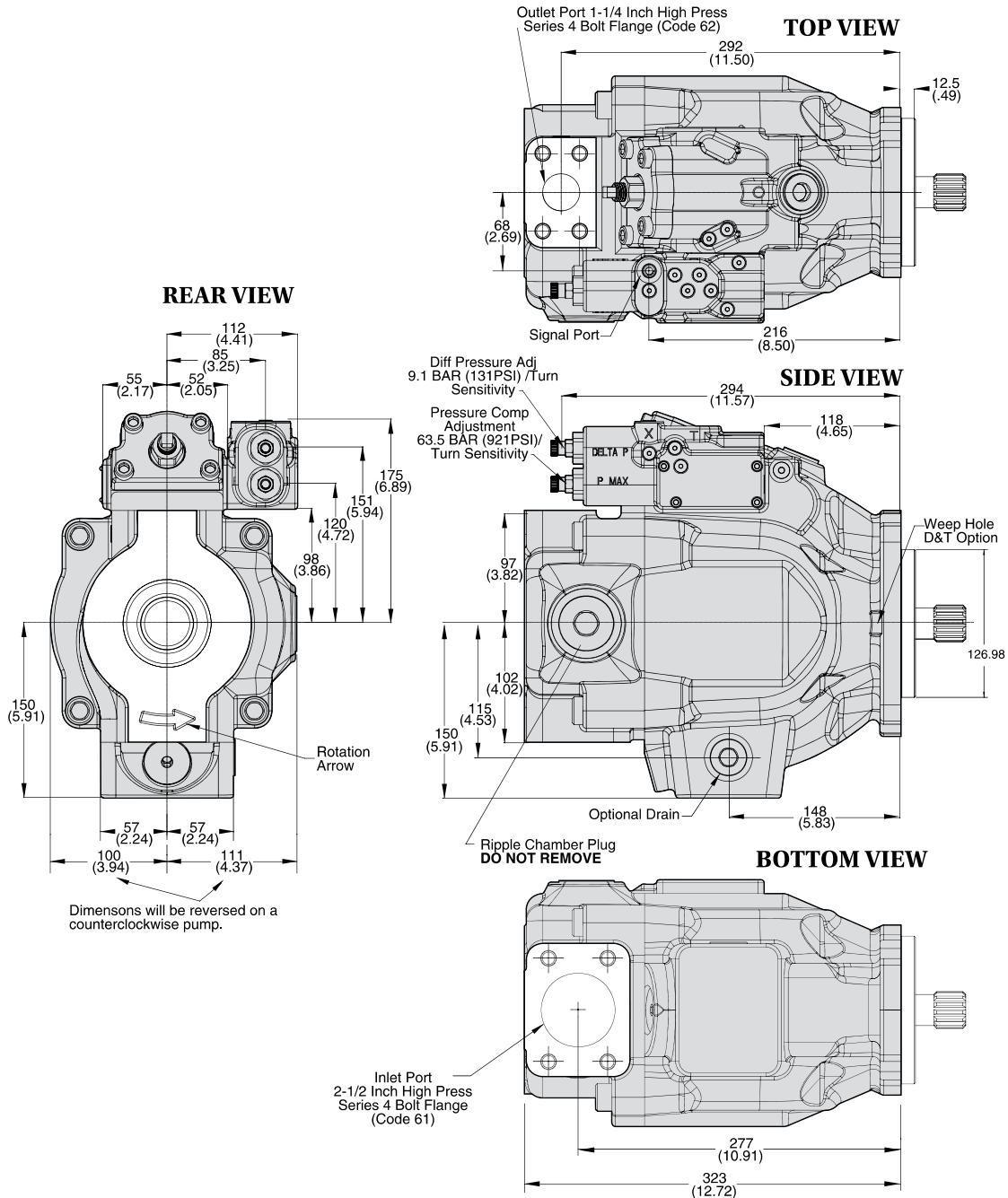

Pump Installation - P2-105 Thru-Shaft Option

Thru-Shaft Option	A	B	C	D	E	F UNC	F Metric	G UNC	G Metric	Pump Weight
A1	323 (12.72)	Ø 82.626/ 82.575 (3.252/ 3.250)	106.3 (4.19)	N/A	SAE-A Spline 9 Tooth 16/32 Pitch	1/2-13 UNC-2B THD	M10 x 1.5 THD	N/A	N/A	61 (134)
B1	356 (14.02)	Ø 101.676/ 101.625 (4.002/ 4.001)	146.1 (5.75)	N/A	SAE-B Spline 13 Tooth 16/32 Pitch	1/2-13 UNC-2B THD	M12 x 1.75 THD	N/A	N/A	64 (140)
B2	356 (14.02)	Ø 101.676/ 101.625 (4.002/ 4.001)	146.1 (5.75)	N/A	SAE-BB Spline 15 Tooth 16/32 Pitch	1/2-13 UNC-2B THD	M12 x 1.75 THD	N/A	N/A	64 (140)
C1	358 (14.09)	Ø 127.075/ 127.025 (5.003/ 5.001)	181 (7.13)	114.5	SAE-C Spline 14 Tooth 12/24 Pitch	1/2-13 UNC-2B THD	M12 x 1.75 THD	5/8-11 UNC-2B THD	M16 x 2 THD	65 (143)
C3	358 (14.09)	Ø 127.075/ 127.025 (5.003/ 5.001)	181 (7.13)	114.5	SAE-C Spline 14 Tooth 12/24 Pitch	1/2-13 UNC-2B THD	M12 x 1.75 THD	5/8-11 UNC-2B THD	M16 x 2 THD	65 (143)

* All shaft Couplings 30 Degrees Involute Spline Flat Root Side Fit

*** Maximum Thru Drive Capability is Limited to 587Nm (5195 lb in)

A1 CONFIGURATION

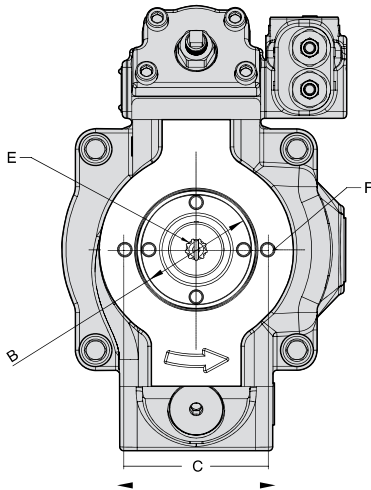

B1 & B2 CONFIGURATION

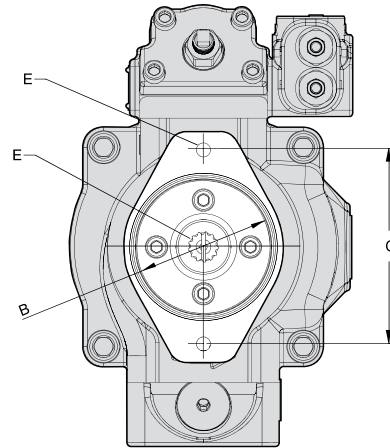

C1 & C3 CONFIGURATION

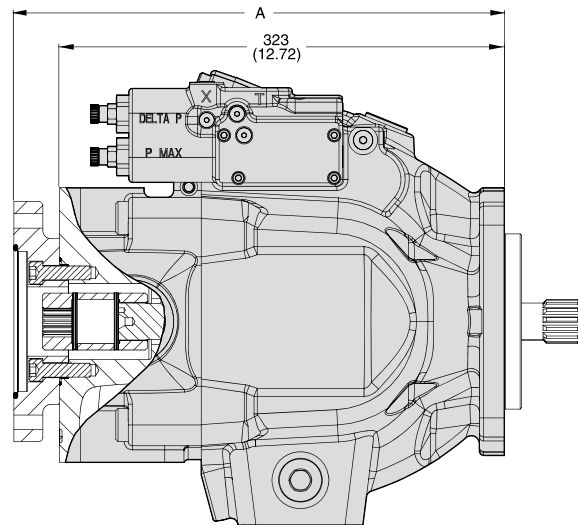
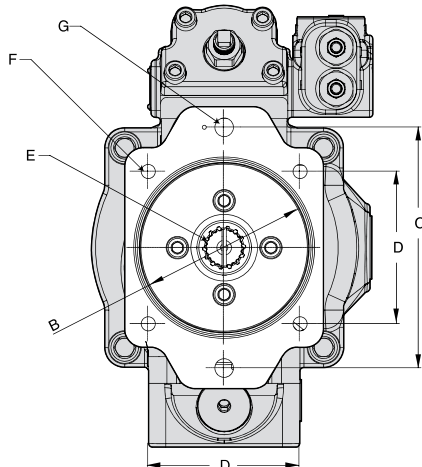

Pump Installation - P2-145 Mounting Flange

Port Options	Drain Port	Inlet Gauge Port Outlet Gauge Port
"A" Side - UNC	SAE-12 Straight Thread O-ring Port 1-1/16-12 UN Thread	SAE-4 Straight Thread O-ring Port 7/16-20 UN Thread
"B" Side - Metric	ISO 6149 Straight Thread O-ring Port M27 x 1.75 Thread	ISO 6149 Straight Thread O-ring Port M12 x 1.5 Thread

SAE D 4-BOLT MOUNTING FLANGE

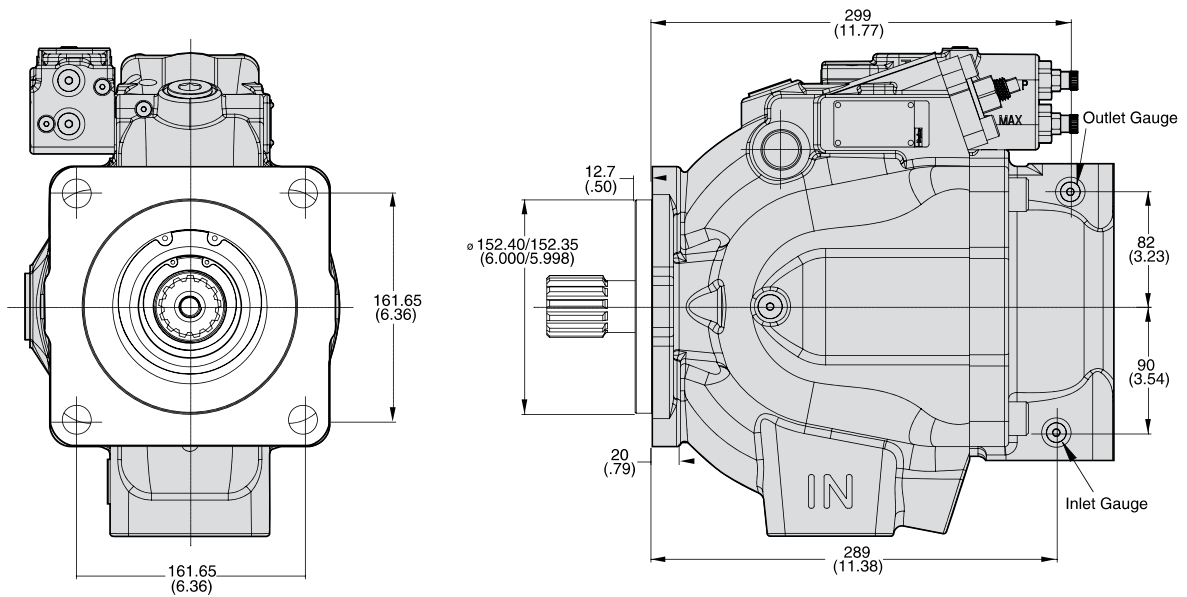

SAE C 2-BOLT MOUNTING FLANGE

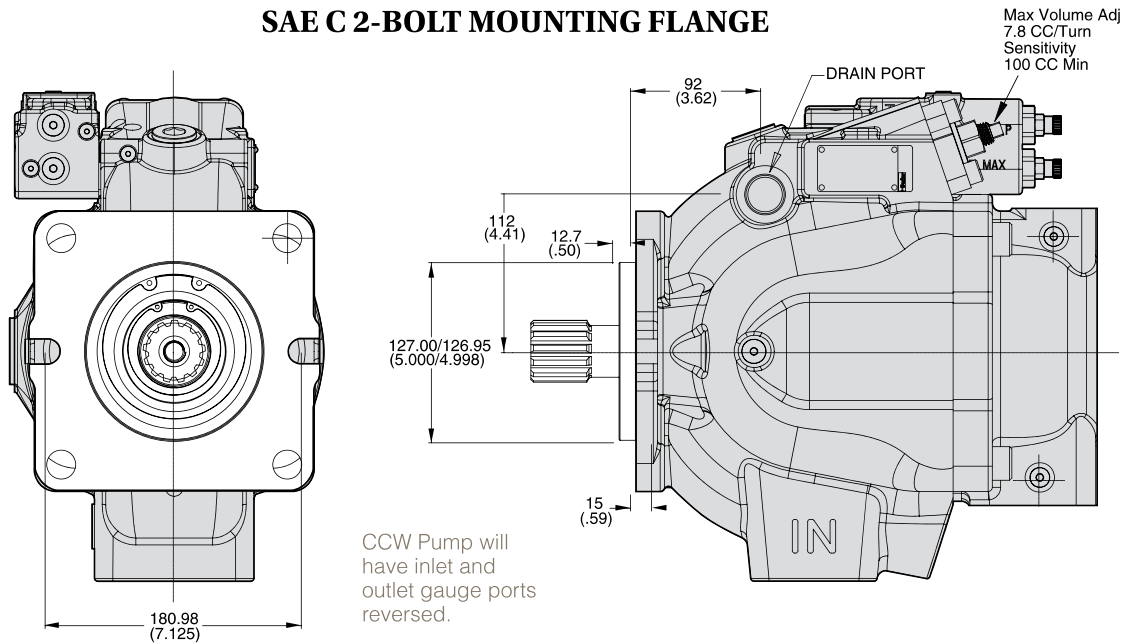

Pump Installation - P2-145 Side Port

Port Options	Drain Port	Inlet Port	Outlet Port	Inlet Gauge Port Outlet Gauge Port Signal Port
"A" Side - UNC	SAE-12 Straight Thread O-ring Port 1-1/16-12 UN-2B	1/2-13 UN	1/2-13 UN	SAE-4 Straight Thread O-ring Port 7/16-20 UN Thread
"B" Side - Metric	ISO 6149 Straight Thread O-ring Port M27 x 2 Thread	M12 x 1.75	M12 x 1.75	ISO 6149 Straight Thread O-ring Port M12 x 1.5 Thread

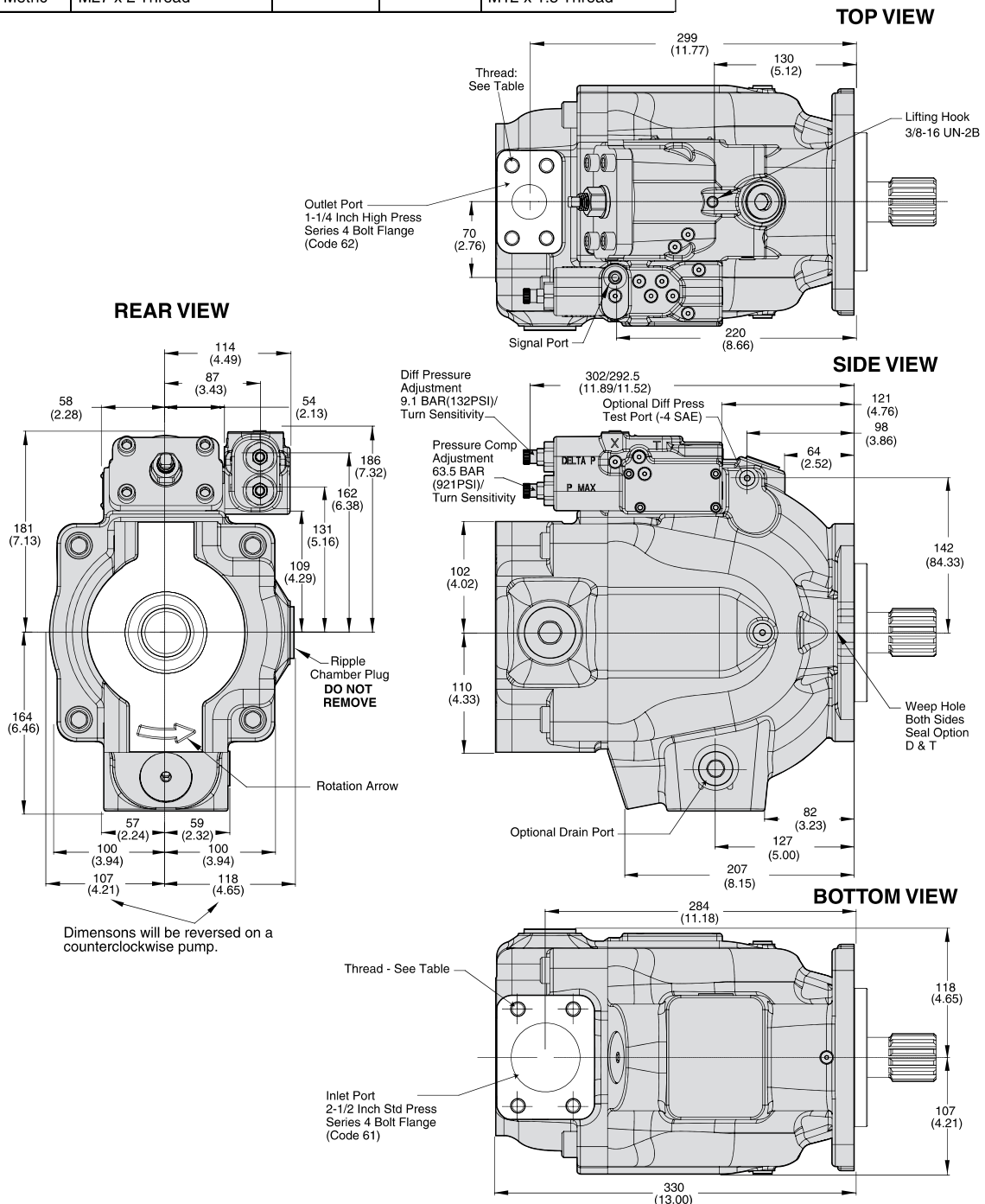

Pump Installation - P2-145 Thru-Shaft Option

Thru-Shaft Option	A	B	C	D	E	F UNC	F Metric	G UNC	G Metric	Pump Weight
A1	329.5 (13.0)	Ø 82.626/ 82.575 (3.252/ 3.250)	106.38 (4.19)	N/A	SAE-A Spline 9 Tooth 16/32 Pitch	3/8-16 UNC-2B THD	M10 x 1.5 THD	N/A	N/A	79.8 (176)
B1	362.5 (14.27)	Ø 101.676/ 101.625 (4.002/ 4.001)	146.05 (5.75)	N/A	SAE-B Spline 13 Tooth 16/32 Pitch	1/2-13 UNC-2B THD	M12 x 1.75 THD	N/A	N/A	82.6 (182)
B2	362.5 (14.27)	Ø 101.676/ 101.625 (4.002/ 4.001)	146.05 (5.75)	N/A	SAE-BB Spline 15 Tooth 16/32 Pitch	1/2-13 UNC-2B THD	M12 x 1.75 THD	N/A	N/A	82.6 (182)
C1	364.5 (14.35)	Ø 127.075/ 127.025 (5.003/ 5.001)	180.98 (7.13)	N/A	SAE-C Spline 14 Tooth 12/24 Pitch	5/8-11 UNC-2B THD	M16 x 2 THD	1/2-13 UNC-2B THD	M12 x 1.75 THD	83.9 (185)
C2	364.5 (14.35)	Ø 127.075/ 127.025 (5.003/ 5.001)	180.98 (7.13)	N/A	SAE-C Spline 14 Tooth 12/24 Pitch	5/8-11 UNC-2B THD	M16 x 2 THD	1/2-13 UNC-2B THD	M12 x 1.75 THD	83.9 (185)
C3	364.5 (14.35)	Ø 127.075/ 127.025 (5.003/ 5.001)	180.98 (7.13)	114.5	SAE-C Spline 14 Tooth 12/24 Pitch	5/8-11 UNC-2B THD	M16 x 2 THD	1/2-13 UNC-2B THD	M12 x 1.75 THD	83.9 (185)
C4	364.5 (14.35)	Ø 127.075/ 127.025 (5.003/ 5.001)	180.98 (7.13)	114.5	SAE-CC Spline 17 Tooth 12/24 Pitch	5/8-11 UNC-2B THD	M16 x 2 THD	1/2-13 UNC-2B THD	M12 x 1.75 THD	83.9 (185)
D3	375 (14.76)	Ø 152.475/ 152.425 (6.003/ 6.001)	N/A	161.65	SAE-D Spline 13 Tooth 8/16 Pitch	N/A	N/A	3/4-10 UNC-2B THD	M16 x 2 THD	88.0 (194)

*** Maximum Thru Drive Capability is Limited to 1217Nm (10777 lb in)

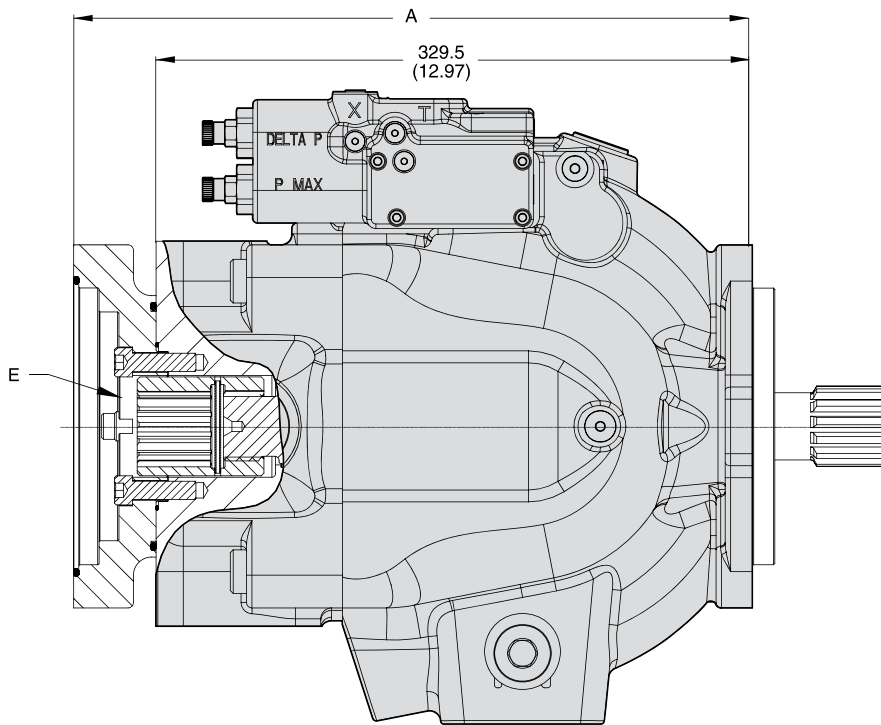

Pump Installation - P2-145 Thru-Shaft Option

A1 CONFIGURATION

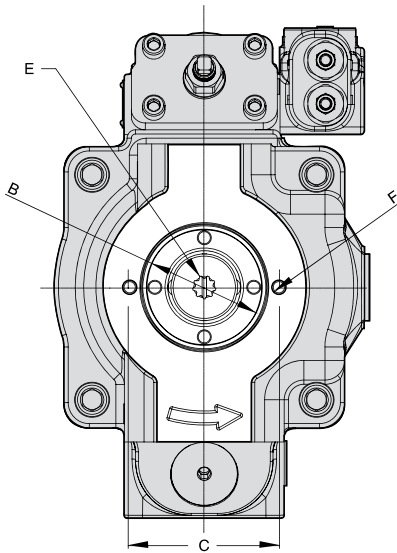

B1 & B2 CONFIGURATION

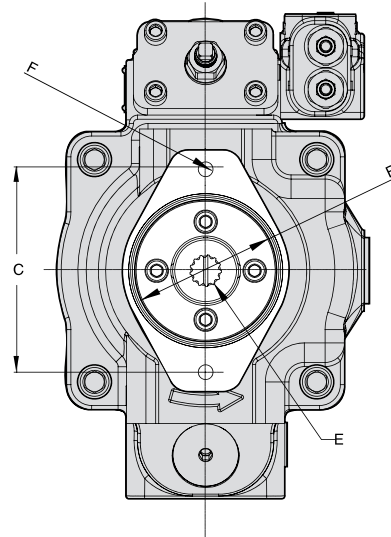

C1, C2, C3 & C4 CONFIGURATION

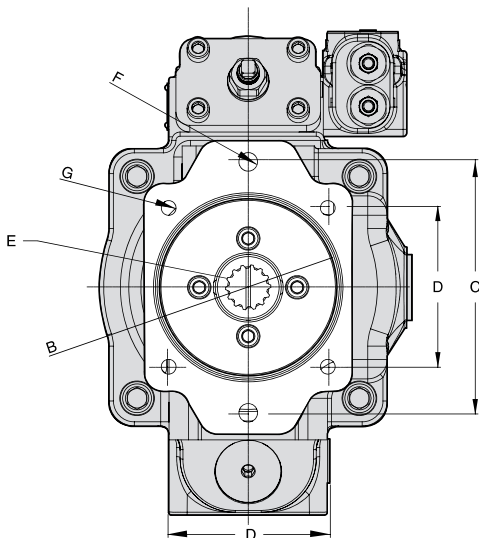

D3 CONFIGURATION

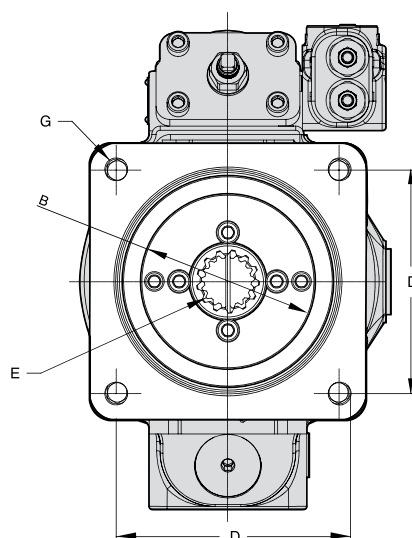

Pump Installation- P2 Shaft Options

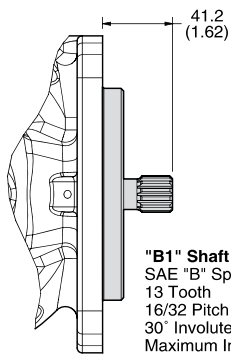

"B1" Shaft Option
 SAE "B" Spline
 13 Tooth
 16/32 Pitch
 30° Involute Spline
 Maximum Input Torque:
 209 Nm (1852 lb in)

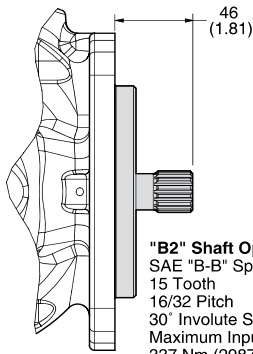

"B2" Shaft Option
 SAE "B-B" Spline
 15 Tooth
 16/32 Pitch
 30° Involute Spline
 Maximum Input Torque:
 337 Nm (2987 lb in)

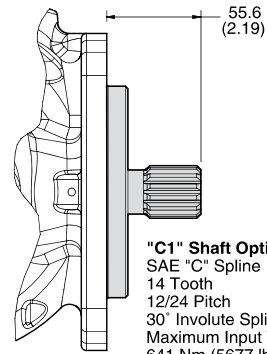

"C1" Shaft Option
 SAE "C" Spline
 14 Tooth
 12/24 Pitch
 30° Involute Spline
 Maximum Input Torque:
 641 Nm (5677 lb in)

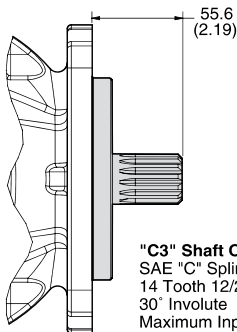

"C3" Shaft Option
 SAE "C" Spline No Undercut
 14 Tooth 12/24 Pitch
 30° Involute
 Maximum Input Torque:
 769 Nm (6812 lb in)

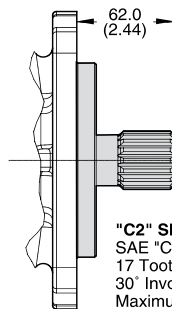

"C2" Shaft Option
 SAE "CC" Spline
 17 Tooth 12/24 Pitch
 30° Involute
 Maximum Input Torque:
 1217 Nm (10777 lb in)

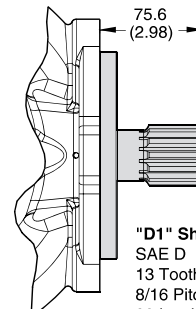

"D1" Shaft Option
 SAE D
 13 Tooth
 8/16 Pitch
 30 Involute Spline
 Maximum Input Torque:
 1701 Nm (15057 lb in)

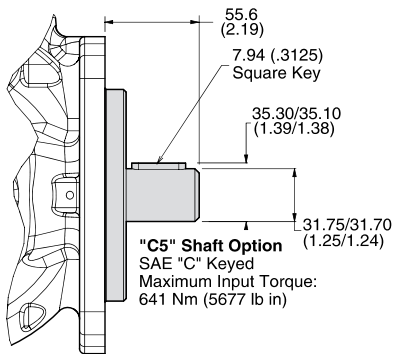

"C5" Shaft Option
 SAE "C" Keyed
 Maximum Input Torque:
 641 Nm (5677 lb in)

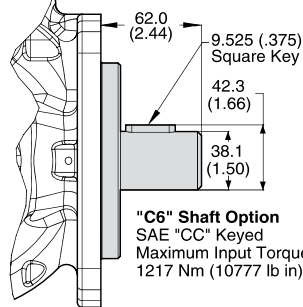

"C6" Shaft Option
 SAE "CC" Keyed
 Maximum Input Torque:
 1217 Nm (10777 lb in)

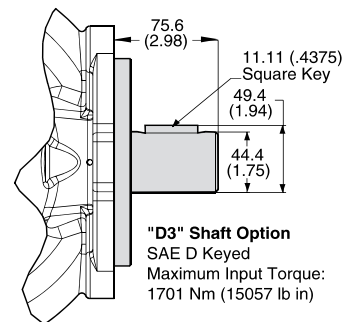

"D3" Shaft Option
 SAE D Keyed
 Maximum Input Torque:
 1701 Nm (15057 lb in)

Torque Control
 Options "TA", "TB", "TC" & "TD"
 200 Nm (1770 lb in) Per Turn
 Approximate Sensitivity

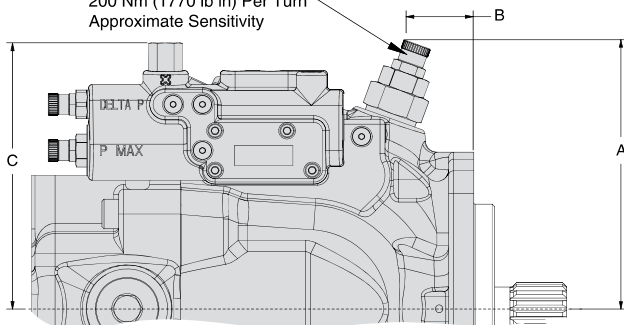

	P2 060	P2075	P2105	P2145
A	163 (6.42)	171 (6.73)	190 (7.48)	202 (7.95)
B	33.7 (1.33)	69 (2.72)	69 (2.72)	69 (2.72)
C	161 (6.34)	154 (6.06)	175 (6.89)	186 (7.32)

P3 Performance and Dimension Section

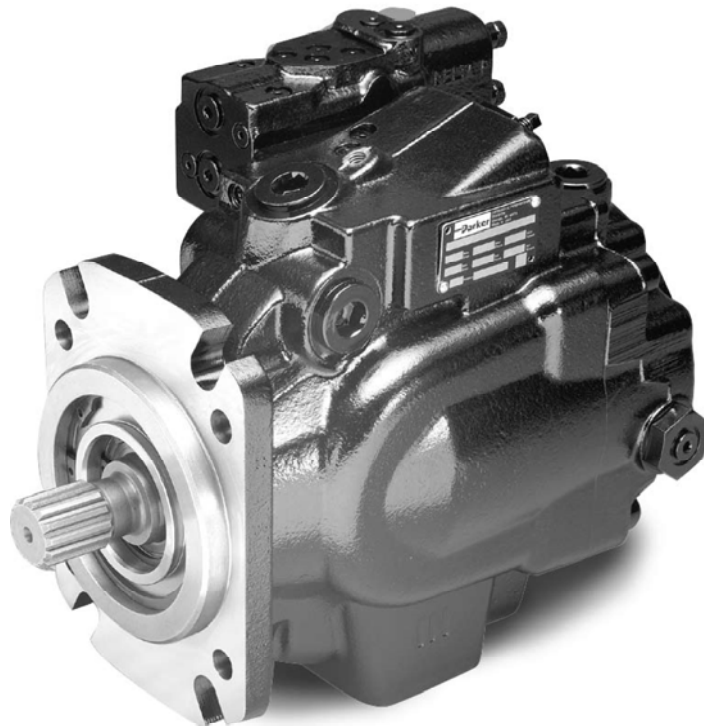

P3 Series Typical Torque Control Characteristics

Fluid: Mineral oil ISO VG 32 @ 40° C

Inlet pressure: 1.0 Bar (14.5 PSI) (Absolute) measured at inlet port.

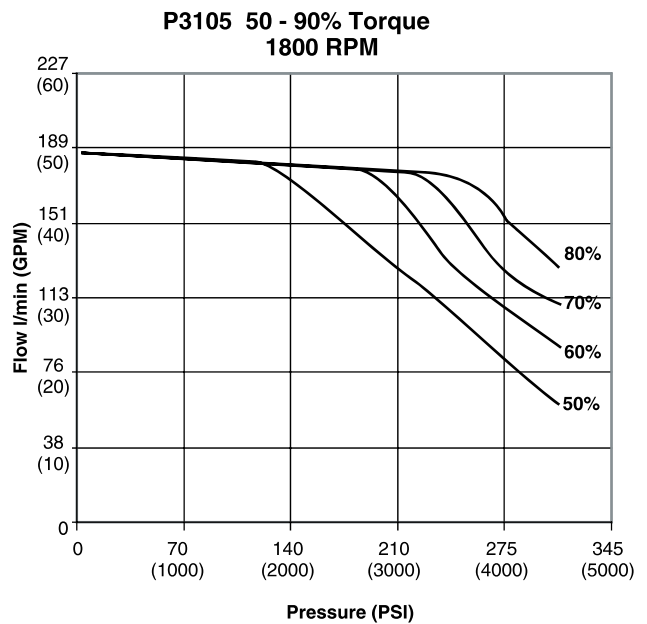
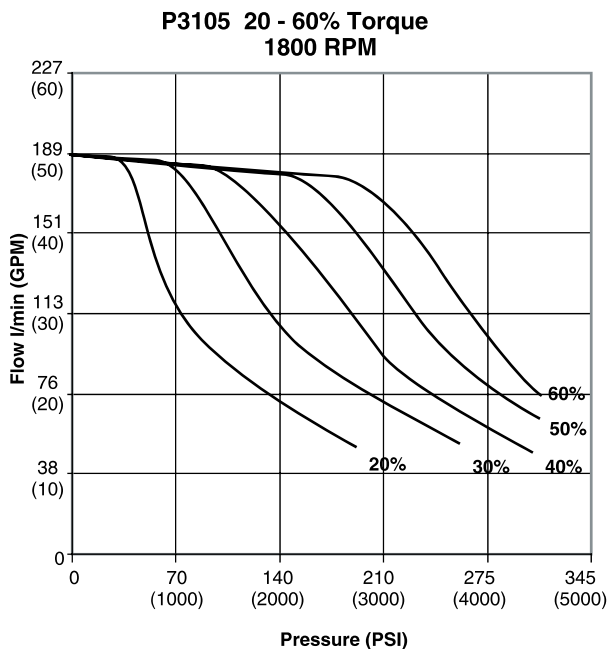
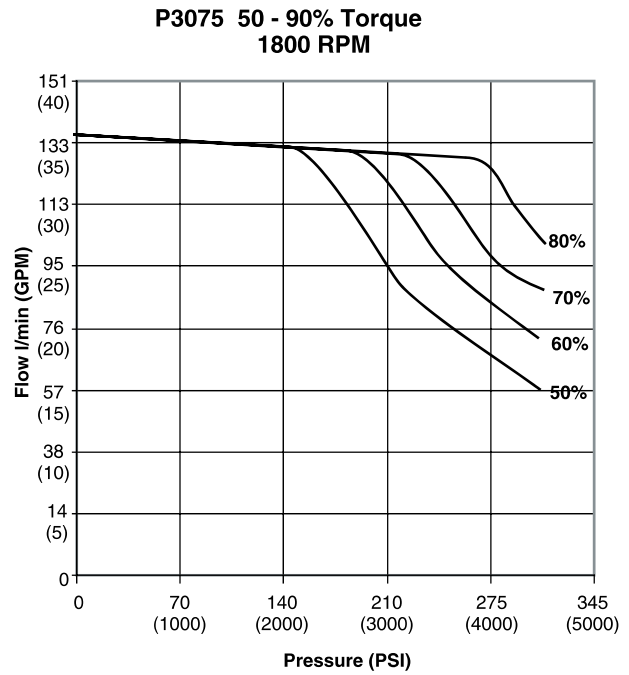
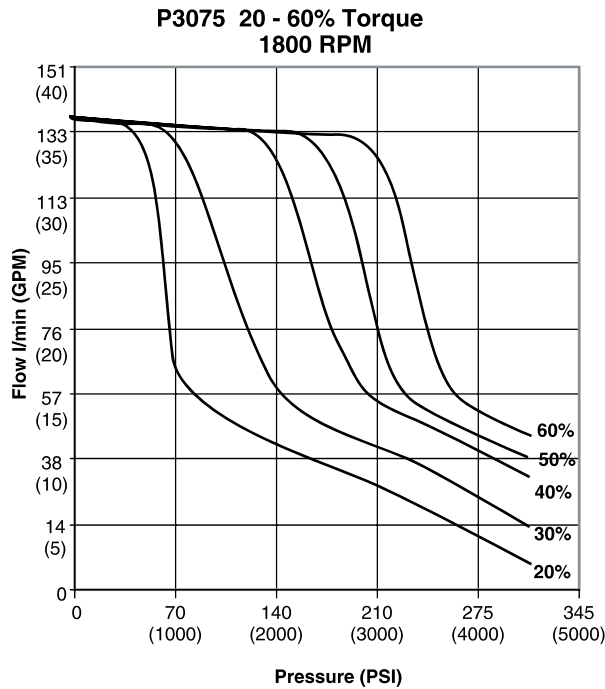

P3 Series Typical Torque Control Characteristics

Fluid: Mineral oil ISO VG 32 @ 40° C

Inlet pressure: 1.0 Bar (14.5 PSI) (Absolute) measured at inlet port.

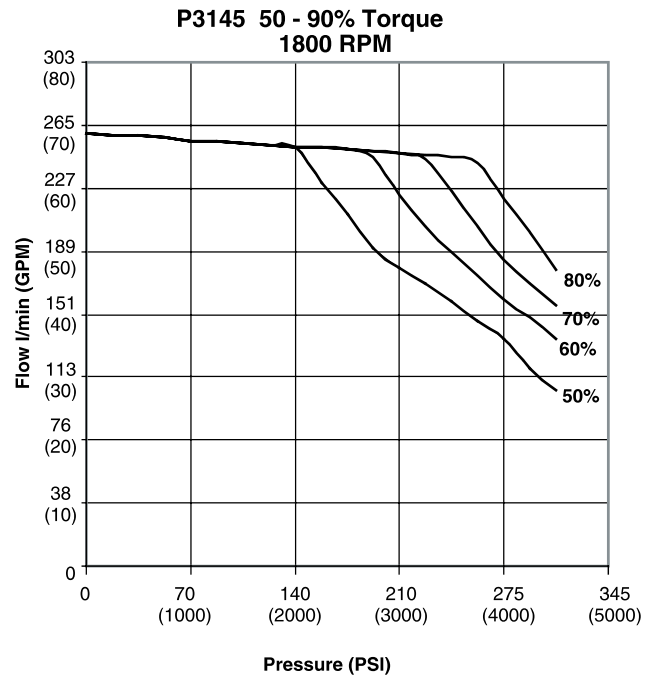
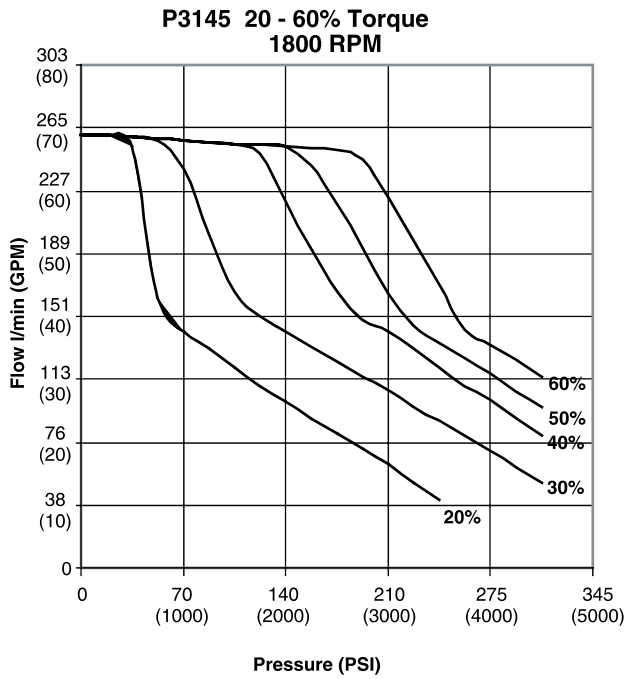

P3 Series Typical Noise Characteristics at Max Displacement

(These are anechoic sound pressure readings.)

Fluid: Mineral oil ISO VG 32 @ 40° C

Inlet pressure: 1.0 Bar (14.5 PSI) (Absolute) measured at inlet port.

P3075 Noise Characteristics at Max Displacement

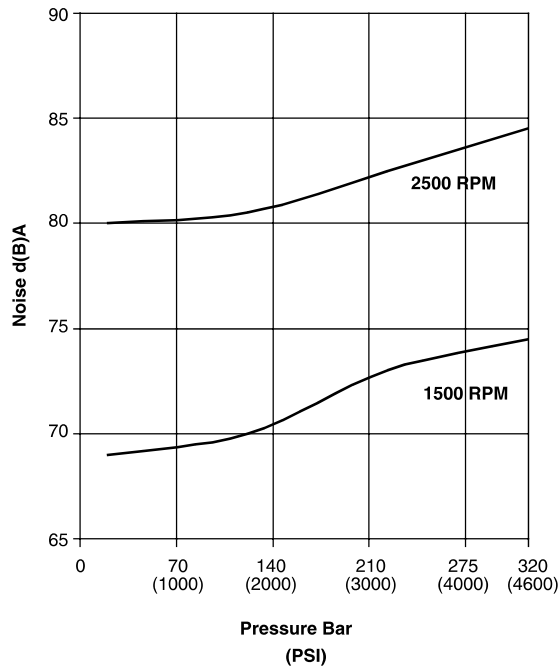

P3145 Noise Characteristics at Max Displacement

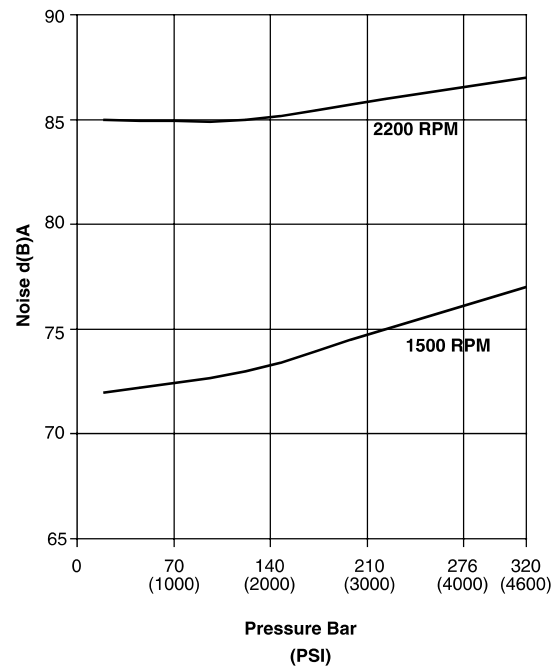

P3105 Noise Characteristics at Max Displacement

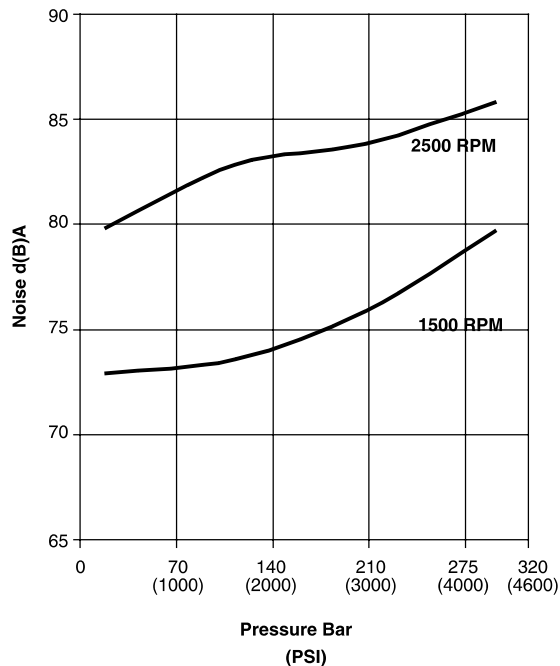

P3 Series Typical Drive Power at Full Displacement

Fluid: Mineral oil ISO VG 32 @ 40° C

Inlet pressure: 1.0 Bar (14.5 PSI) (Absolute) measured at inlet port.

P3075 Input Power - Full Stroke

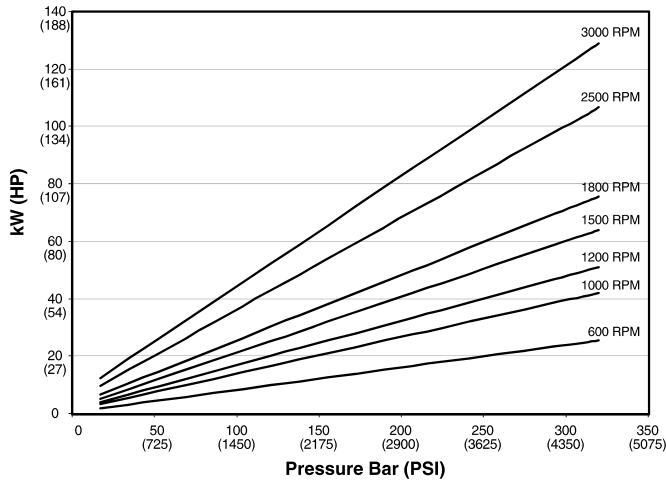

P3105 Input Power - Full Stroke

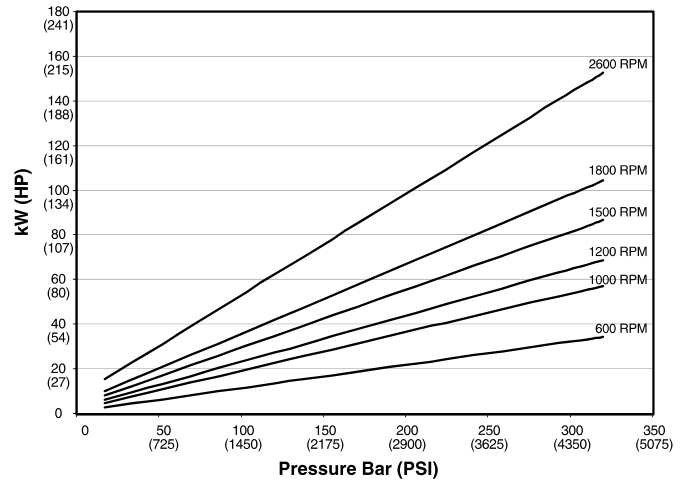

P3145 Input Power - Full Stroke

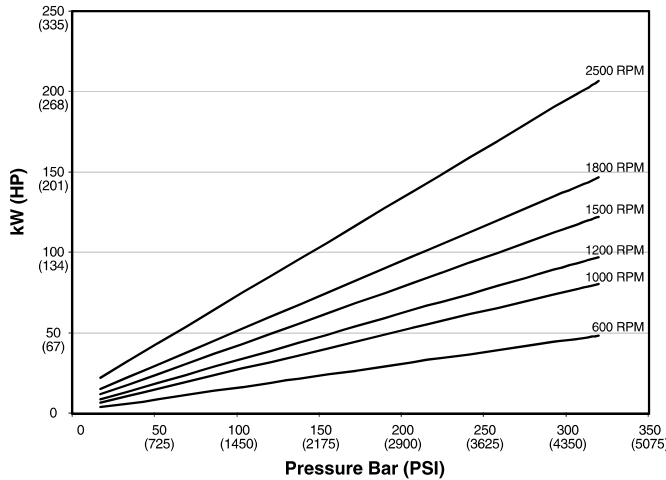

P3 Series Typical Compensated Power

Fluid: Mineral oil ISO VG 32 @ 40° C

Inlet pressure: 1.0 Bar (14.5 PSI) (Absolute) measured at inlet port.

P3075 Input Power - Zero Stroke

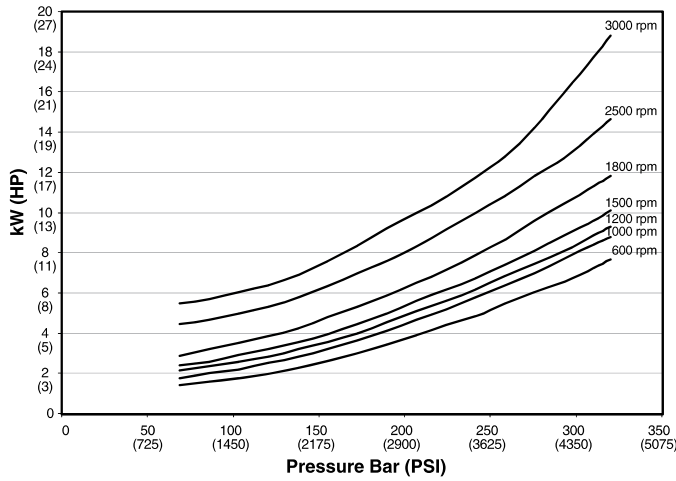

P3105 Input Power - Zero Stroke

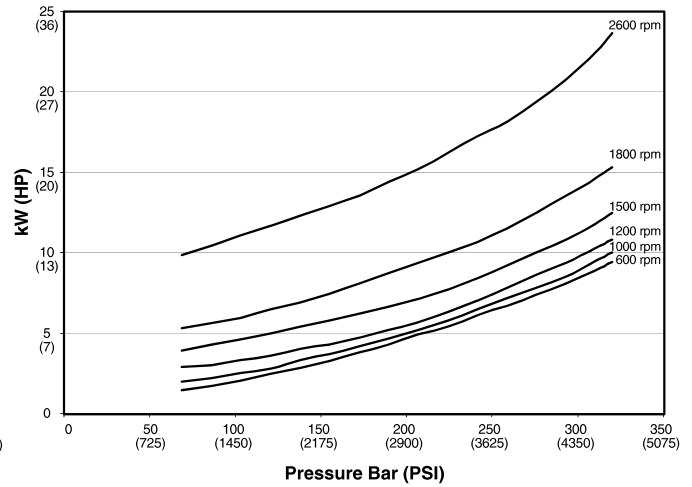

P3145 Input Power - Zero Stroke

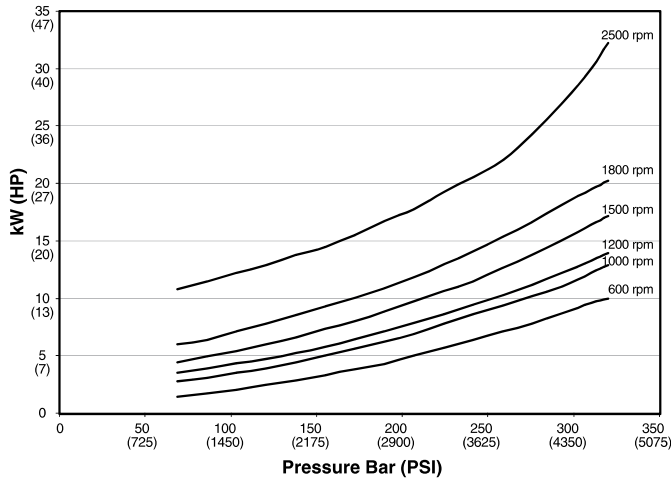

P3 Series Typical Efficiency at Full Displacement @ 1800 RPM

Fluid: Mineral oil ISO VG 32 @ 40° C

Inlet pressure: 1.0 Bar (14.5 PSI) (Absolute) measured at inlet port.

P3075 Efficiency at 1800 RPM

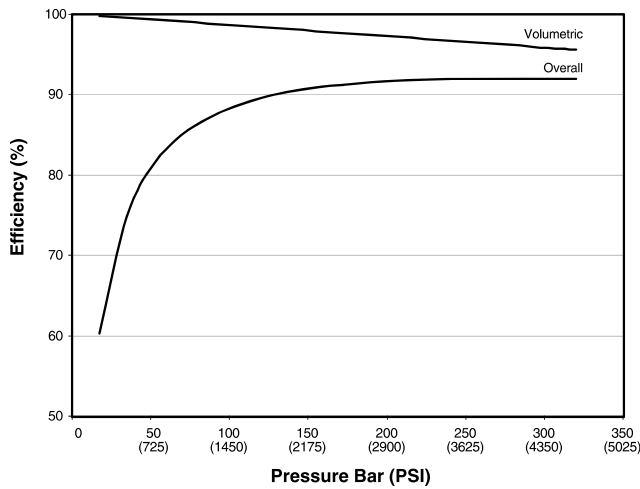

P3105 Efficiency at 1800 RPM

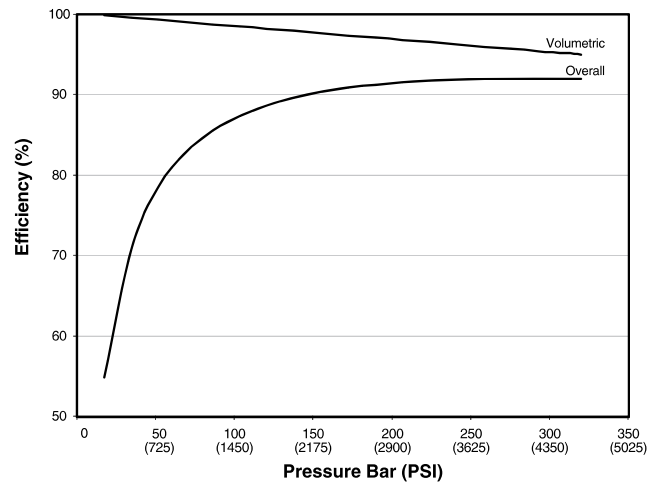

P3145 Efficiency at 1800 RPM

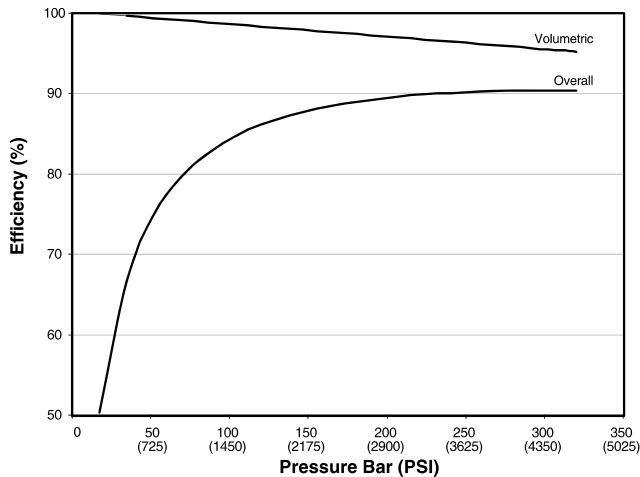

P3 Series Typical Flow vs. Pressure

Fluid: Mineral oil ISO VG 32 @ 40° C

Inlet pressure: 1.0 Bar (14.5 PSI) (Absolute) measured at inlet port.

P3075 Outlet Flow - Full Stroke

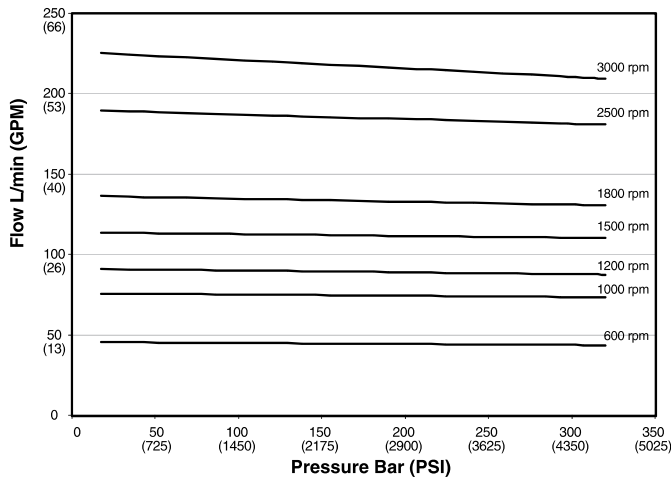

P3105 Outlet Flow - Full Stroke

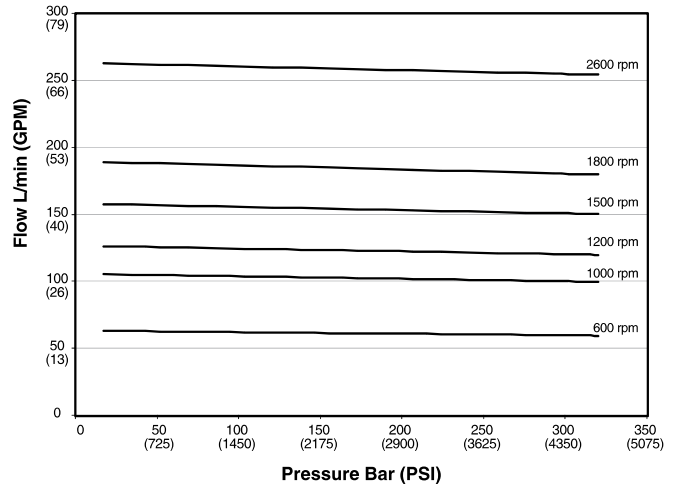

P3145 Outlet Flow - Full Stroke

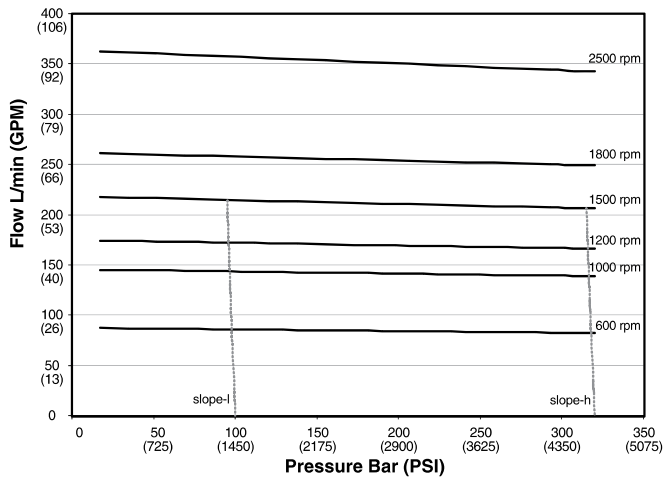

P3 Series Typical Compensated Control Drain Flow

Fluid: Mineral oil ISO VG 32 @ 40° C

Inlet pressure: 1.0 Bar (14.5 PSI) (Absolute) measured at inlet port.

P3075 Control Drain Flow at Zero Stroke

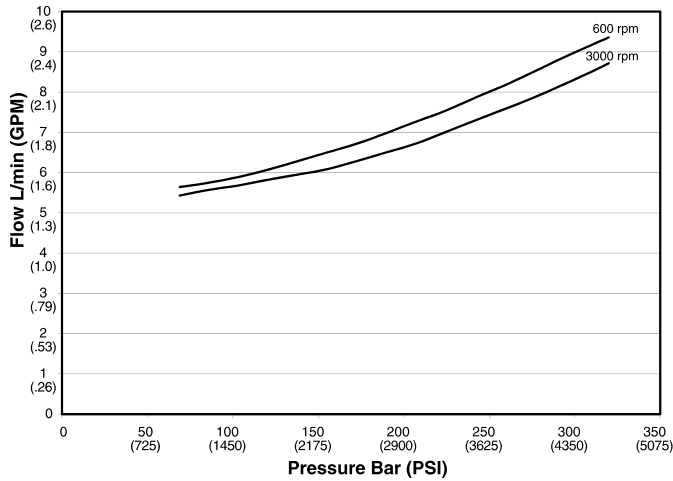

P3105 Control Drain Flow at Zero Stroke

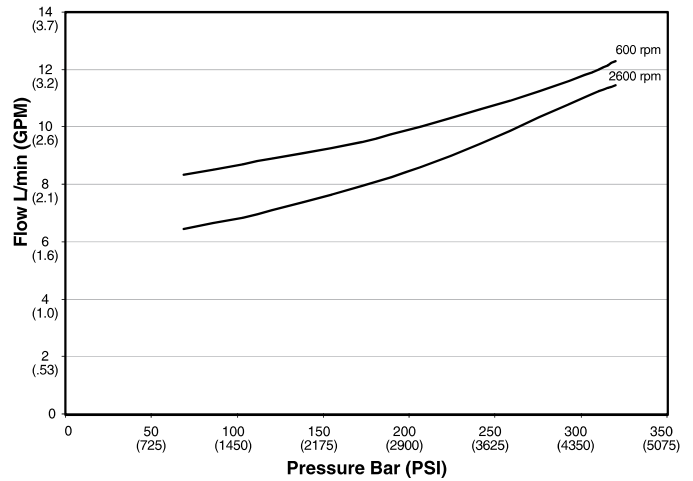

P3145 Control Drain Flow at Zero Stroke

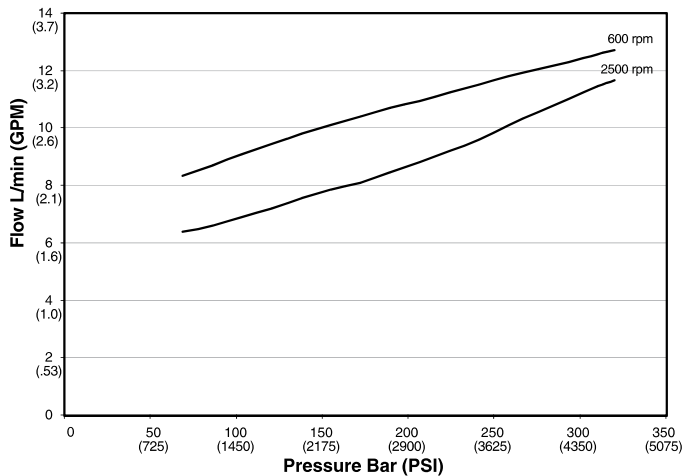

P3 Series Typical Inlet Characteristics vs. Speed at Various Percentage Displacements

Fluid: Mineral oil ISO VG 32 @ 40° C

Inlet pressure: 1.0 Bar (14.5 PSI) (Absolute) measured at inlet port.

P3075 Inlet Characteristics

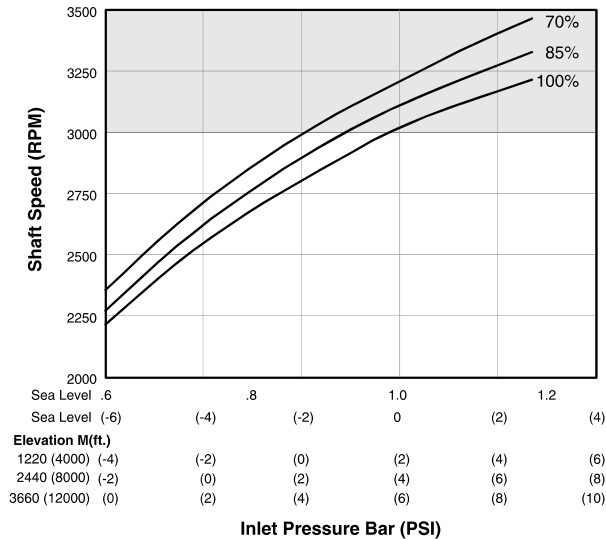

P3105 Inlet Characteristics

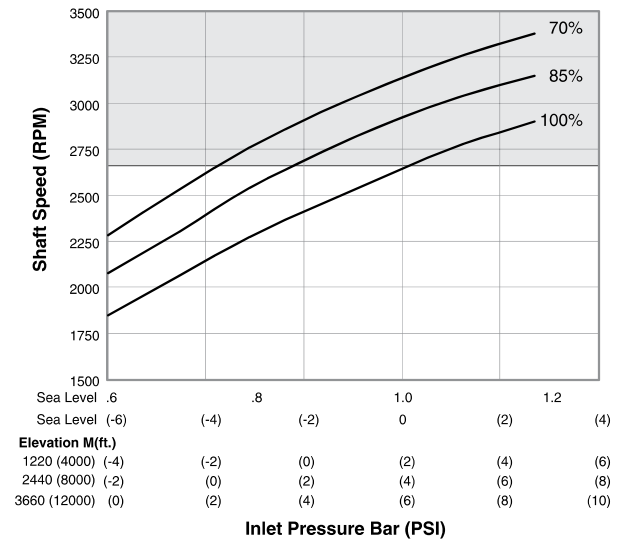

The charts on this page are used to determine the acceptable inlet pressure conditions at various shaft speeds and pump displacements. The data is also converted for inlet pressure levels at various elevations. To read the chart, from the vertical axis, select the shaft speed and go across to the appropriate displacement curve, then move down to the minimum acceptable inlet pressure for those conditions, at the desired elevation.

For example, for the P3075, at 3000 RPM, and 100% displacement (75 cc/r), the minimum acceptable inlet pressure at sea level is 0 psig. For these same speed displacement conditions, at 4000 feet, the minimum acceptable inlet pressure is 2 psig. If the maximum pump displacement is adjusted down to 60 cc/r, read across from 3000 RPM to the 80% displacement curve, and at 4000 ft., the minimum acceptable inlet pressure is .3 psig.

P3145 Inlet Characteristics

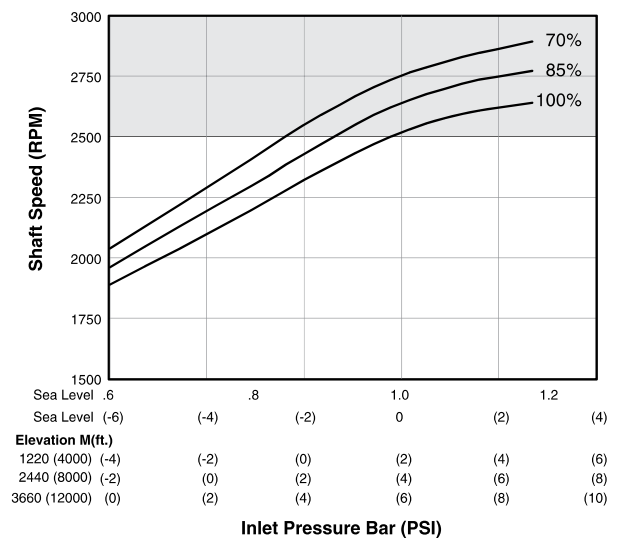

 For operation at these speeds, please consult factory for approval.

Pump Installation - P3-075 Mounting Flange

Port Options	Airbleed Port Vent Port
"A" Side - UNC	SAE-4 Straight Thread O-ring Port 7/8-20 UN Thread
"B" Side - Metric	ISO 6149 Straight Thread O-ring Port M12 x 1.5 Thread

SAE C 2-BOLT AND 4-BOLT MOUNTING FLANGE

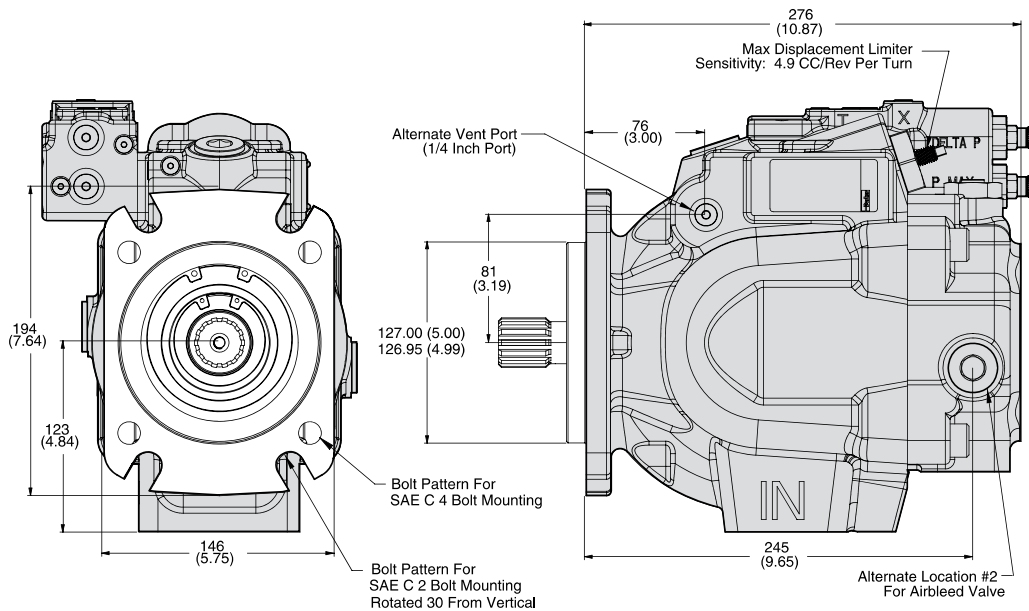

Pump Installation - P3-075 Side Port

Port Options	Inlet Port	Outlet Port	Inlet Gauge Port Outlet Gauge Port Airbleed Port Signal Port
"A" Side - UNC	1/2-13 UNC	7/16-14 UNC	SAE-4 Straight Thread O-ring Port 7/16-20 UN Thread
"B" Side - Metric	M12 x 1.75	M12 x 1.75	ISO 6149 Straight Thread O-ring Port M12 x 1.5 Thread

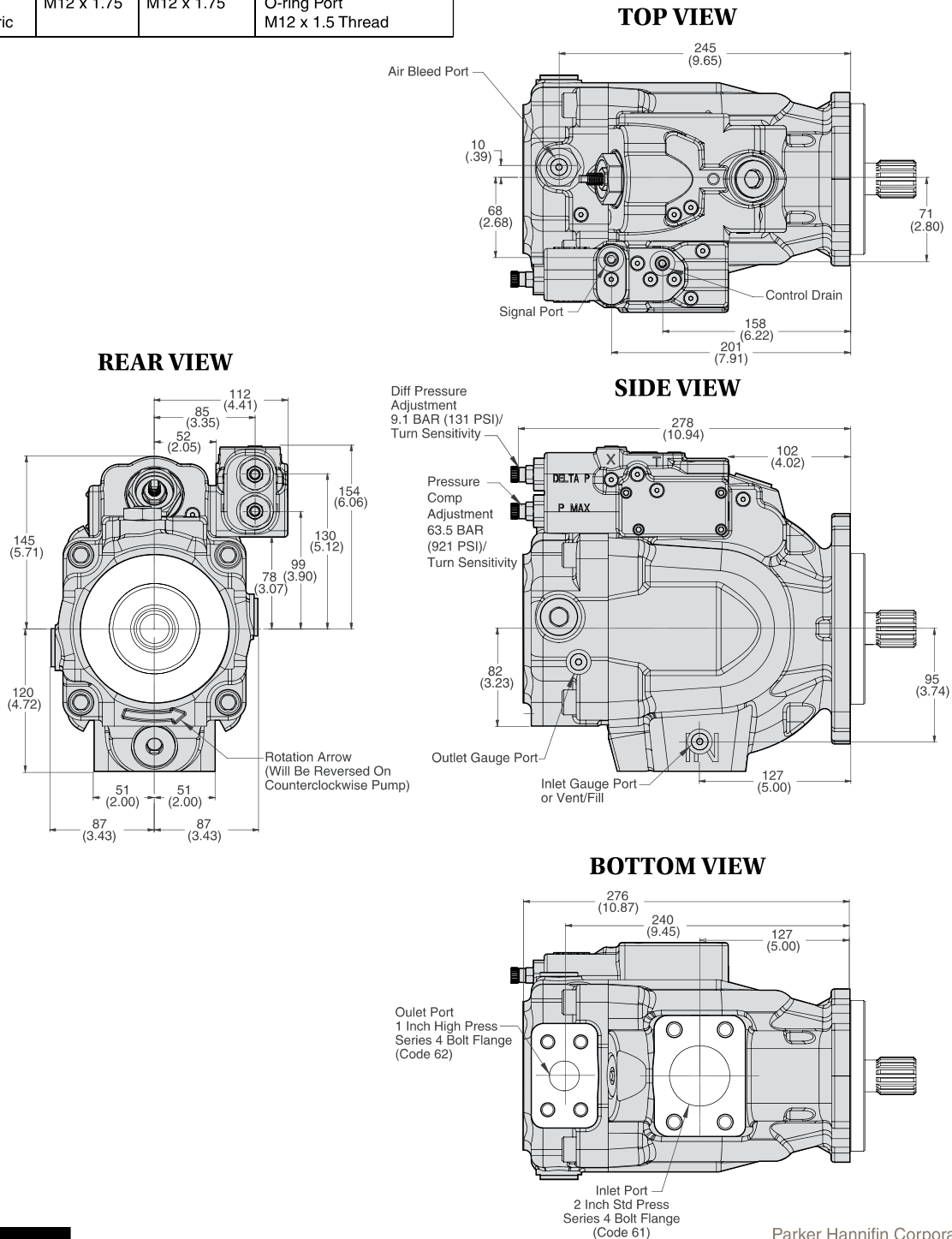

Pump Installation - P3-075 Thru-Shaft Option

Thru-Shaft Option	A	B	C	D	E	F "A" & "G"	F "B" & "G"
A1	292.5 (11.51)	Ø 82.626/ 82.575 (3.252/ 3.250)	106.3 (4.19)	N/A	SAE-A Spline 9 Tooth 16/32 Pitch	3/8-16 UNC-2B THD	M10 x 1.5 THD
B1	325.5 (12.81)	Ø 101.676/ 101.625 (4.002/ 4.001)	146.1 (5.75)	N/A	SAE-B Spline 13 Tooth 16/32 Pitch	1/2-13 UNC-2B THD	M12 x 1.75 THD
B2	325.5 (12.81)	Ø 101.676/ 101.625 (4.002/ 4.001)	146.1 (5.75)	N/A	SAE-BB Spline 15 Tooth 16/32 Pitch	1/2-13 UNC-2B THD	M12 x 1.75 THD
C1	327.5 (12.89)	Ø 127.075/ 127.025 (5.003/ 5.001)	181 (7.13)	114.5	SAE-C Spline 14 Tooth 12/24 Pitch	5/8-11 UNC-2B THD	M16 x 2 THD
C3	327.5 (12.89)	Ø 127.075/ 127.025 (5.003/ 5.001)	181 (7.13)	114.5	SAE-C Spline 14 Tooth 12/24 Pitch	1/2-13 UNC-2B THD	M12 x 1.75 THD

* All shaft Couplings 30 Degrees Involute Spline Flat Root Side Fit

A1 CONFIGURATION

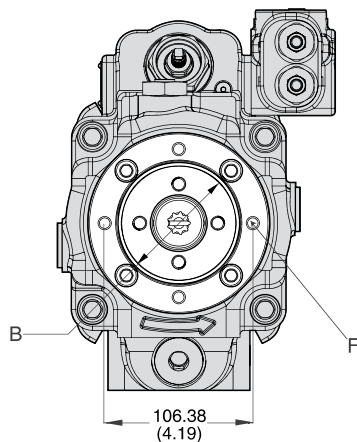

B1 & B2 CONFIGURATION

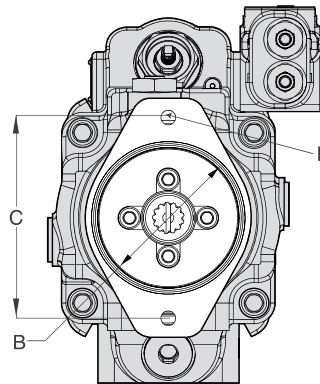

C1 & C3 CONFIGURATION

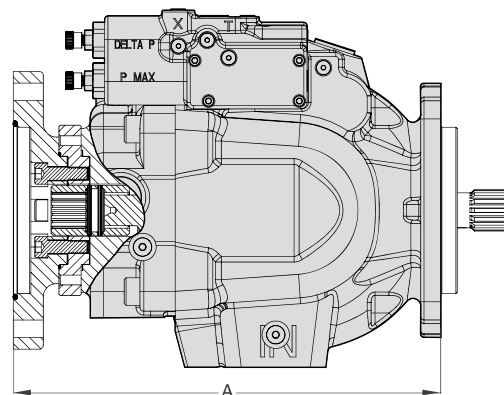
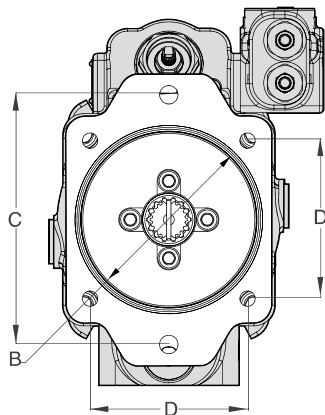

Max Thru-Drive Torque is 429 Nm (3800 lb in)

Pump Installation - P3-105 Mounting Flange

Port Options	Airbleed Port Vent Port
"A" Side - UNC	SAE-4 Straight Thread O-ring Port 7/16-20 UN Thread
"B" Side - Metric	ISO 6149 Straight Thread O-ring Port M12 x 1.5 Thread

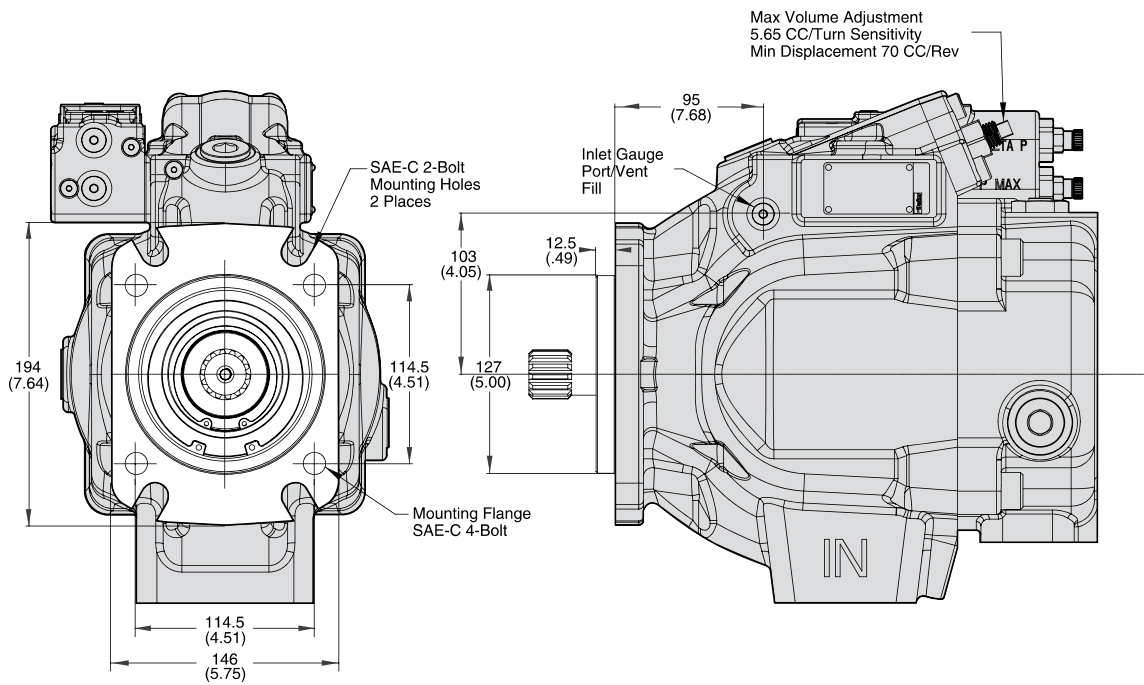

Pump Installation - P3-105 Side Port

Port Options	Inlet Port	Outlet Port	Inlet Gauge Port Outlet Gauge Port Airbleed Port Control Drain Signal Port
"A" Side - UNC	1/2-13 UNC	1/2-13 UNC	SAE-4 Straight Thread O-ring Port 7/16-20 UN Thread
"B" Side - Metric	M12 x 1.75	M12 x 1.75	ISO 6149 Straight Thread O-ring Port M12 x 1.5 Thread

TOP VIEW

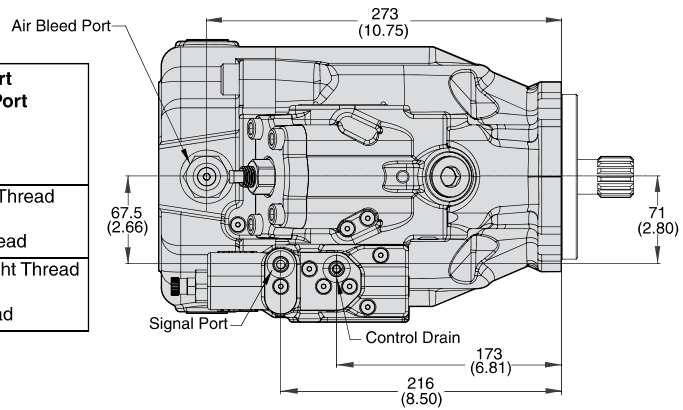

REAR VIEW

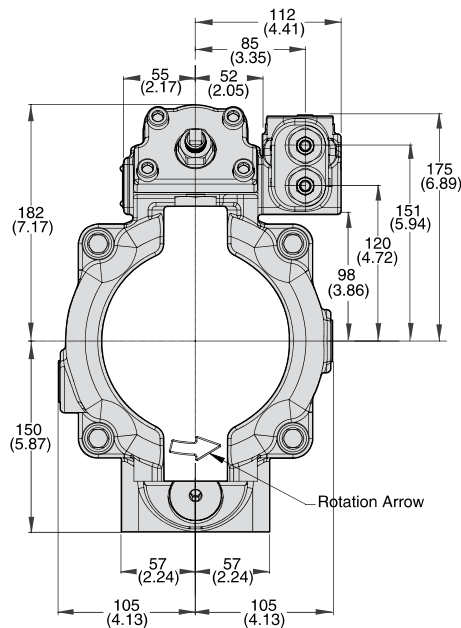

SIDE VIEW

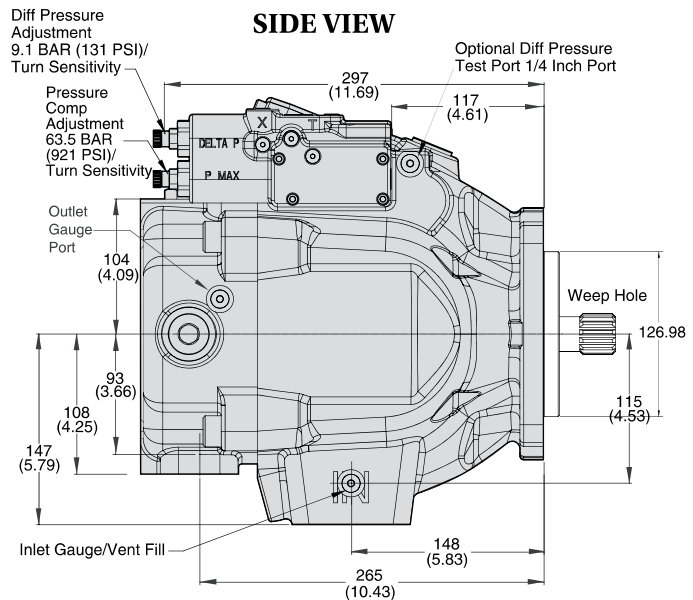

BOTTOM VIEW

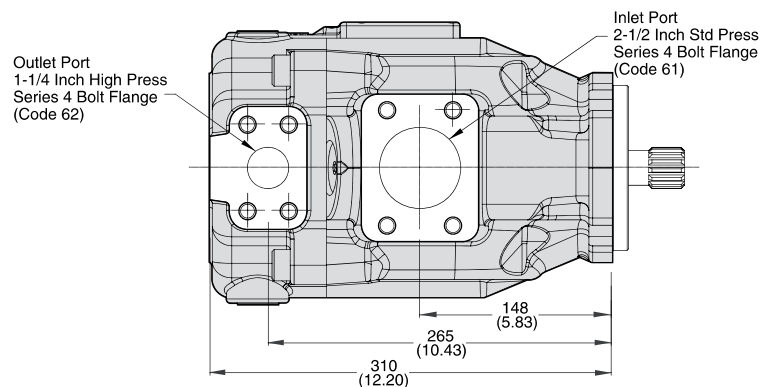

Pump Installation - P3-105 Thru-Shaft Option

Thru-Shaft Option	A	B	C	D	E	F UNC	F Metric	G UNC	G Metric
A1	292.5 (11.51)	Ø 82.626/ 82.575 (3.252/ 3.250)	106.3 (4.19)	N/A	SAE-A Spline 9 Tooth 16/32 Pitch	3/8-16 UNC-2B THD	M10 x 1.5 THD	N/A	N/A
B1	325.5 (12.81)	Ø 101.676/ 101.625 (4.002/ 4.001)	146.1 (5.75)	N/A	SAE-B Spline 13 Tooth 16/32 Pitch	1/2-13 UNC-2B THD	M12 x 1.75 THD	N/A	N/A
B2	325.5 (12.81)	Ø 101.676/ 101.625 (4.002/ 4.001)	146.1 (5.75)	N/A	SAE-BB Spline 15 Tooth 16/32 Pitch	1/2-13 UNC-2B THD	M12 x 1.75 THD	N/A	N/A
C1	327.5 (12.89)	Ø 127.075/ 127.025 (5.003/ 5.001)	181 (7.13)	114.5	SAE-C Spline 14 Tooth 12/24 Pitch	1/2-13 UNC-2B THD	M12 x 1.75 THD	5/8-11 UNC-2B THD	M16 x 2 THD
C3	327.5 (12.89)	Ø 127.075/ 127.025 (5.003/ 5.001)	181 (7.13)	114.5	SAE-C Spline 14 Tooth 12/24 Pitch	1/2-13 UNC-2B THD	M12 x 1.75 THD	5/8-11 UNC-2B THD	M16 x 2 THD

* All shaft Couplings 30 Degrees Involute Spline Flat Root Side Fit

*** Maximum Thru Drive Capability is Limited to 587Nm (5195 lb in)

A1 CONFIGURATION

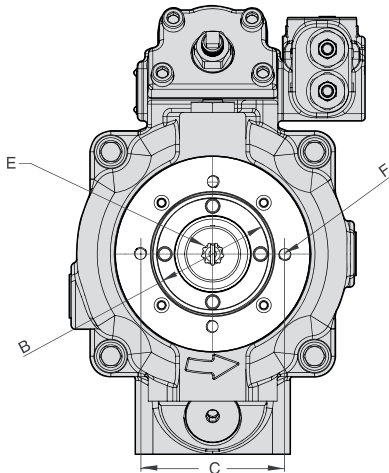

B1 & B2 CONFIGURATION

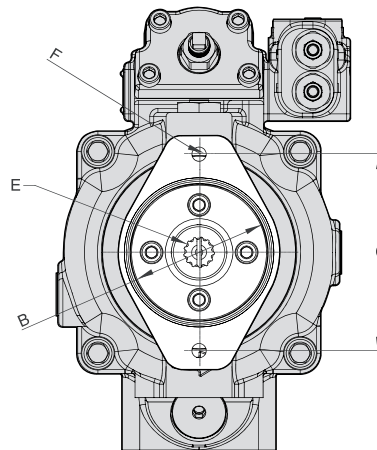

C1 & C3 CONFIGURATION

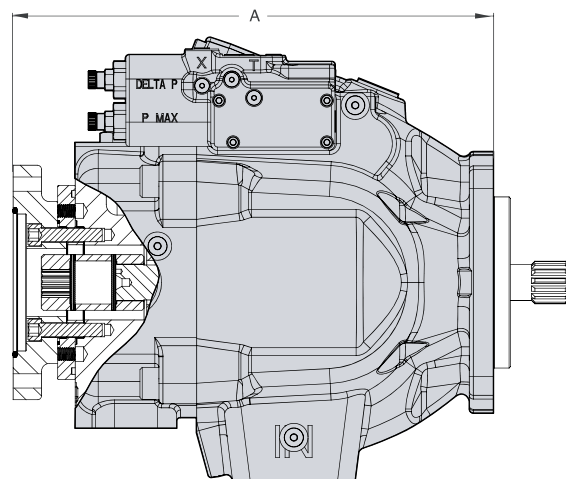
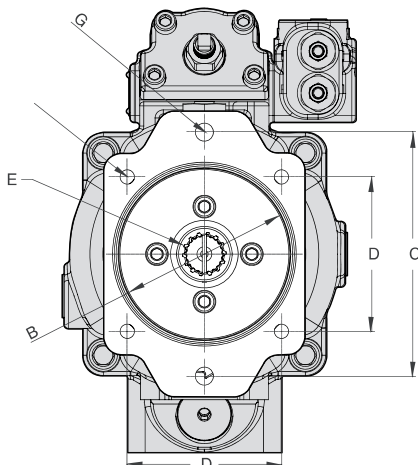

Pump Installation - P3-145 Mounting Flange

Port Options	Airbleed Port Vent Port
"A" Side - UNC	SAE-4 Straight Thread O-ring Port 7/16-20 UN Thread
"B" Side - Metric	ISO 6149 Straight Thread O-ring Port M12 x 1.5 Thread

SAE C 2-BOLT MOUNTING FLANGE

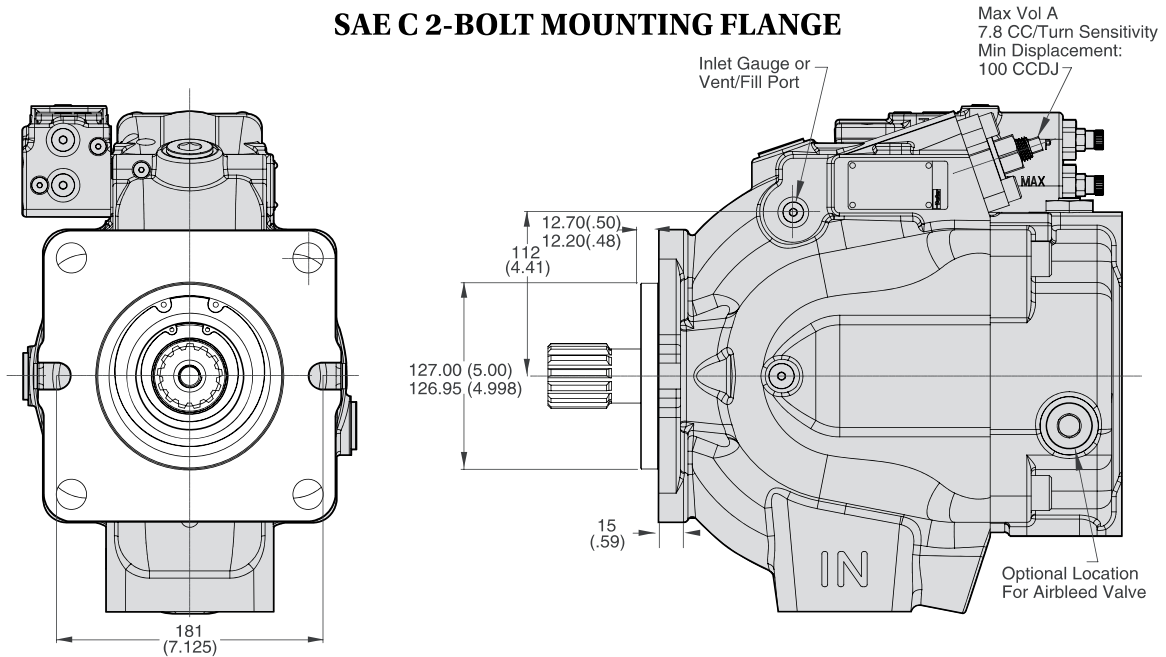

SAE D 4-BOLT MOUNTING FLANGE

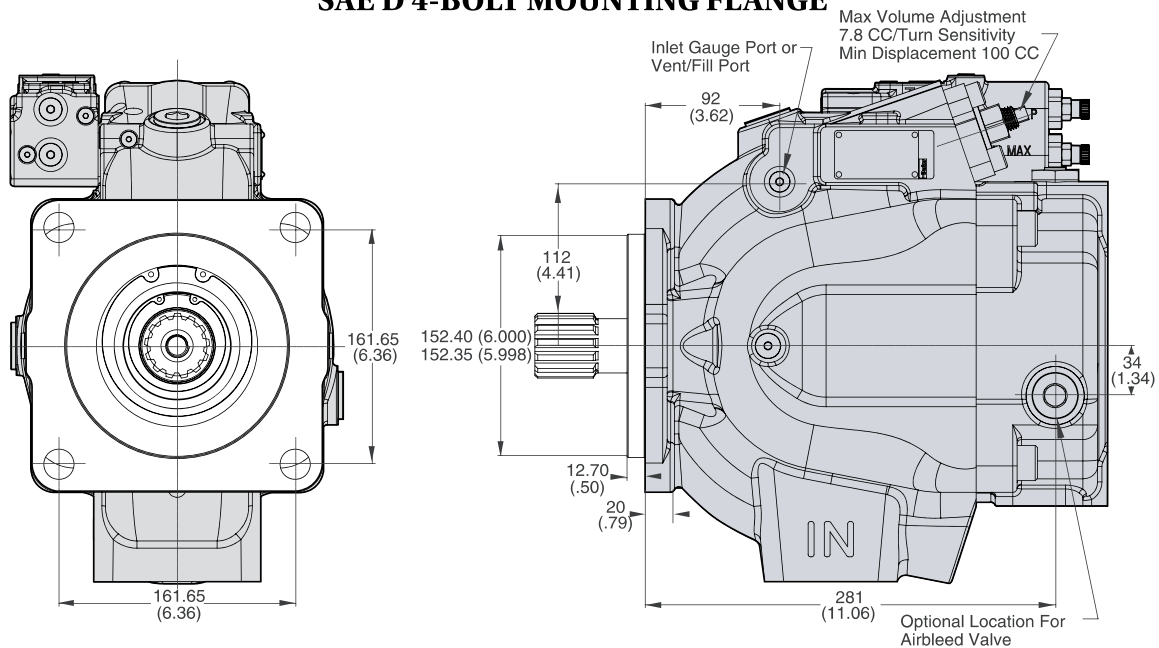

Pump Installation - P3-145 Side Port

Port Options	Inlet Port	Outlet Port	Inlet Gauge Port Outlet Gauge Port Airbleed Port Control Drain Signal Port
"A" Side - UNC	1/2-13 UNC	1/2-13 UNC	SAE-4 Straight Thread O-ring Port 7/16-20 UN Thread
"B" Side - Metric	M12 x 1.75	M12 x 1.75	ISO 6149 Straight Thread O-ring Port M12 x 1.5 Thread

TOP VIEW

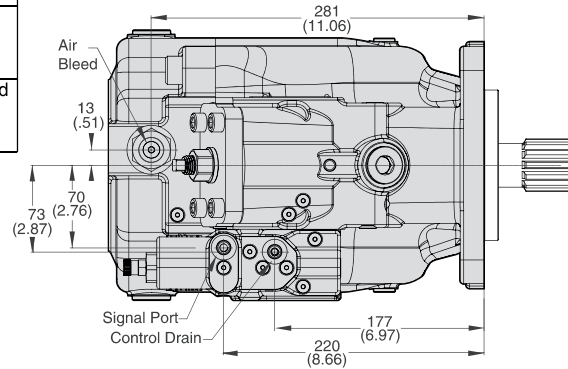

REAR VIEW

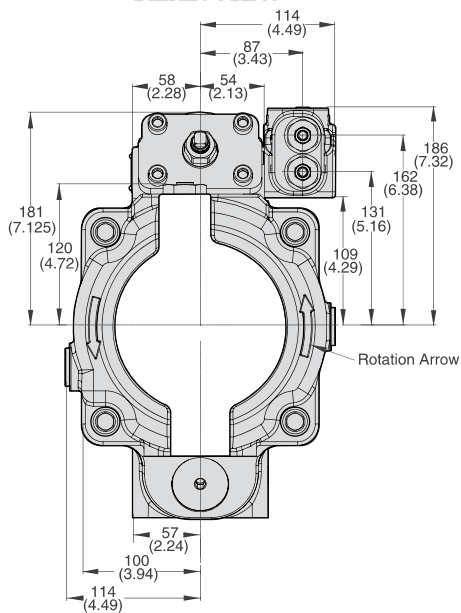

SIDE VIEW

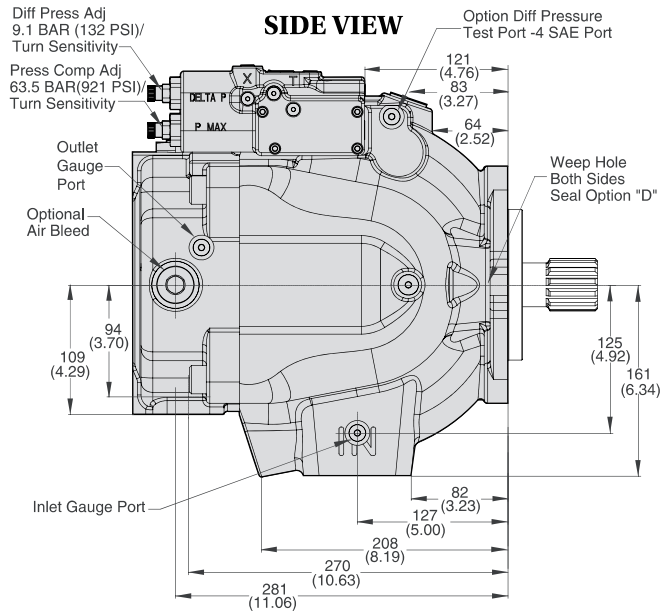

BOTTOM VIEW

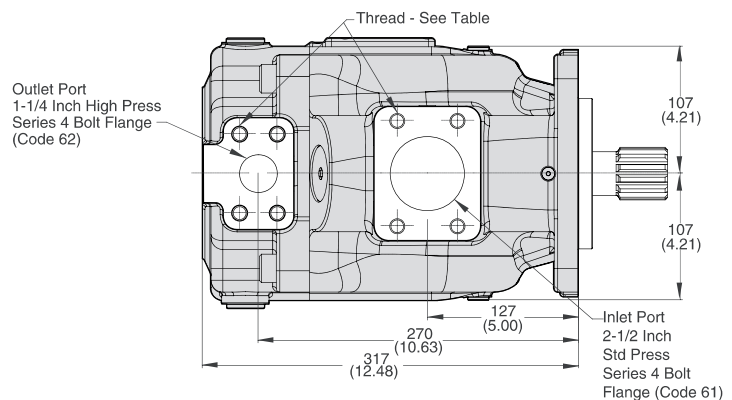

Pump Installation - P3-145 Thru-Shaft Option

Thru-Shaft Option	A	B	C	D	E	F UNC	F Metric	G UNC	G Metric	Pump Weight
A1	329.5 (13.0)	Ø 82.626/ 82.575 (3.252/ 3.250)	106.38 (4.19)	N/A	SAE-A Spline 9 Tooth 16/32 Pitch	3/8-16 UNC-2B THD	M10 x 1.5 THD	N/A	N/A	75.7 (167)
B1	362.5 (14.27)	Ø 101.676/ 101.625 (4.002/ 4.001)	146.05 (5.75)	N/A	SAE-B Spline 13 Tooth 16/32 Pitch	1/2-13 UNC-2B THD	M12 x 1.75 THD	N/A	N/A	78.5 (173)
B2	362.5 (14.27)	Ø 101.676/ 101.625 (4.002/ 4.001)	146.05 (5.75)	N/A	SAE-BB Spline 15 Tooth 16/32 Pitch	1/2-13 UNC-2B THD	M12 x 1.75 THD	N/A	N/A	78.5 (173)
C1	364.5 (14.35)	Ø 127.075/ 127.025 (5.003/ 5.001)	180.98 (7.13)	N/A	SAE-C Spline 14 Tooth 12/24 Pitch	5/8-11 UNC-2B THD	M16 x 2 THD	1/2-13 UNC-2B THD	M12 x 1.75 THD	80.0 (176)
C2	364.5 (14.35)	Ø 127.075/ 127.025 (5.003/ 5.001)	180.98 (7.13)	N/A	SAE-C Spline 17 Tooth 12/24 Pitch	5/8-11 UNC-2B THD	M16 x 2 THD	1/2-13 UNC-2B THD	M12 x 1.75 THD	80.0 (176)
C3	364.5 (14.35)	Ø 127.075/ 127.025 (5.003/ 5.001)	180.98 (7.13)	114.5	SAE-C Spline 14 Tooth 12/24 Pitch	5/8-11 UNC-2B THD	M16 x 2 THD	1/2-13 UNC-2B THD	M12 x 1.75 THD	80.0 (176)
C4	364.5 (14.35)	Ø 127.075/ 127.025 (5.003/ 5.001)	180.98 (7.13)	114.5	SAE-CC Spline 17 Tooth 12/24 Pitch	5/8-11 UNC-2B THD	M16 x 2 THD	1/2-13 UNC-2B THD	M12 x 1.75 THD	80.0 (176)
D3	375 (14.76)	Ø 152.475/ 152.425 (6.003/ 6.001)	N/A	161.65	SAE-D Spline 13 Tooth 8/16 Pitch	N/A	N/A	3/4-10 UNC-2B THD	M16 x 2 THD	83.9 (185)

*** Maximum Thru Drive Capability is Limited to 1217Nm (10777 lb in)

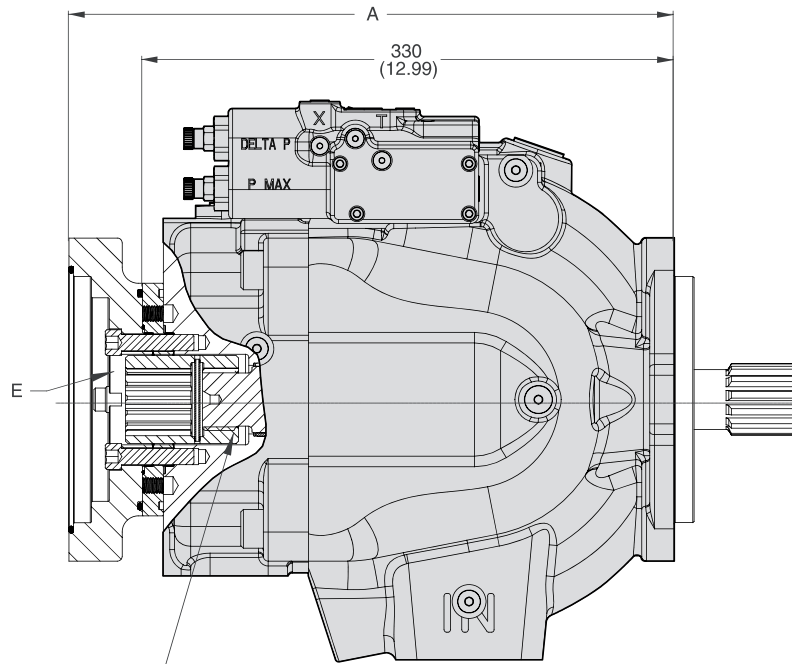

Pump Installation - P3-145 Thru-Shaft Option

A1 CONFIGURATION

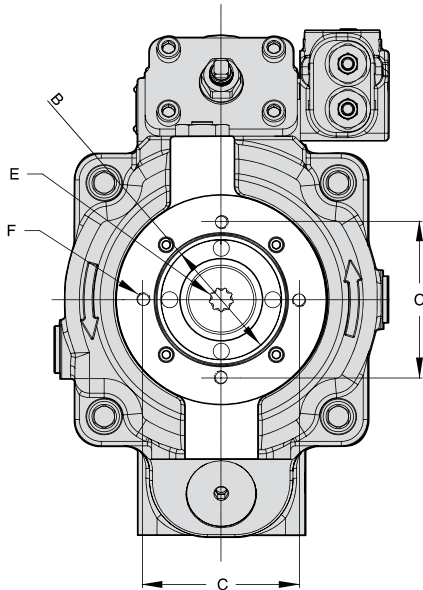

B1 & B2 CONFIGURATION

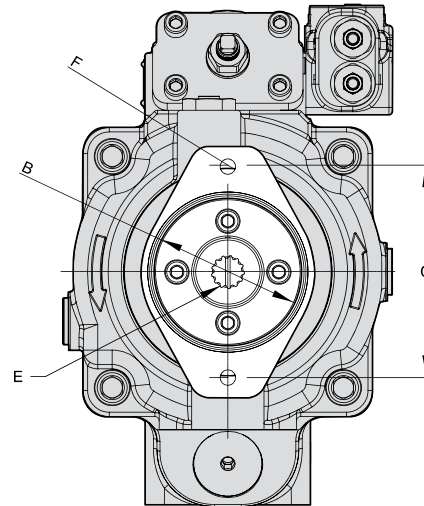

C1, C2, C3 & C4 CONFIGURATION

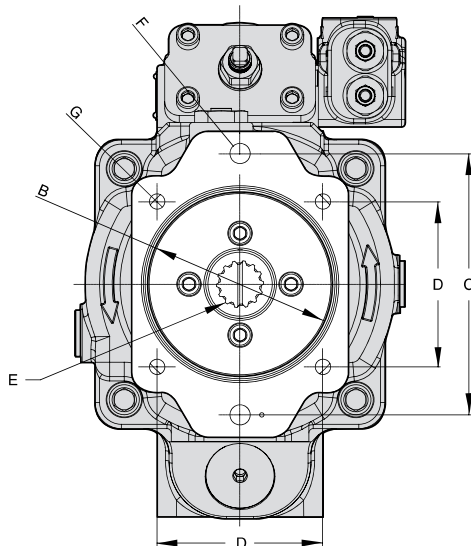

D3 CONFIGURATION

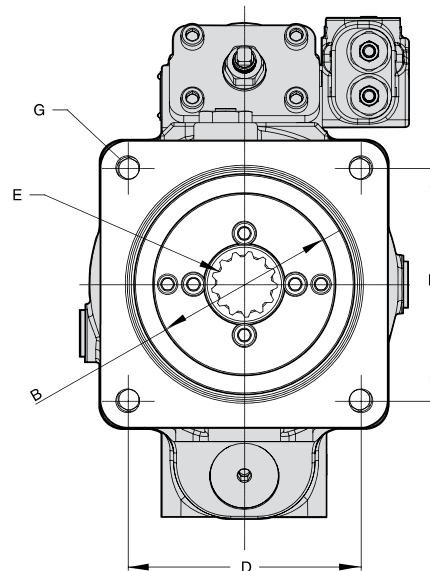

Pump Installation- P3 Shaft Options

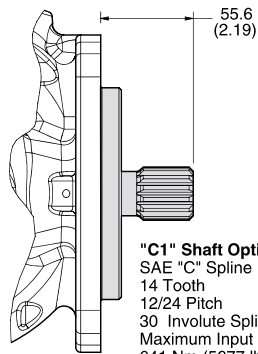

"C1" Shaft Option
 SAE "C" Spline
 14 Tooth
 12/24 Pitch
 30 Involute Spline
 Maximum Input Torque:
 641 Nm (5677 lb in)

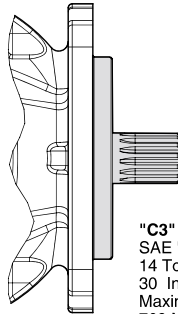

"C3" Shaft Option
 SAE "C" Spline No Undercut
 14 Tooth 12/24 Pitch
 30 Involute
 Maximum Input Torque:
 769 Nm (6812 lb in)

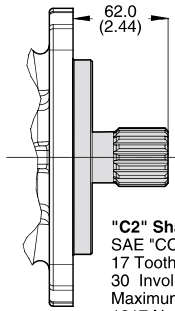

"C2" Shaft Option
 SAE "CC" Spline
 17 Tooth 12/24 Pitch
 30 Involute
 Maximum Input Torque:
 1217 Nm(10777 lb in)

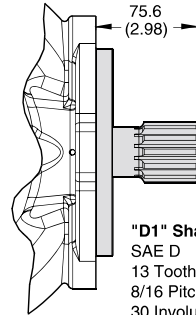

"D1" Shaft Option
 SAE D
 13 Tooth
 8/16 Pitch
 30 Involute Spline
 Maximum Input Torque:
 1701 Nm (15057 lb in)

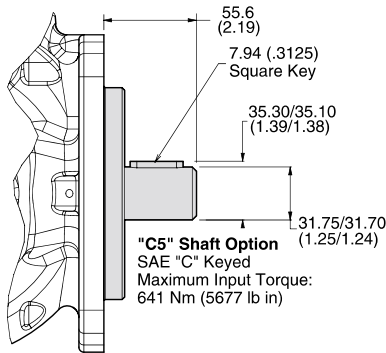

"C5" Shaft Option
 SAE "C" Keyed
 Maximum Input Torque:
 641 Nm (5677 lb in)

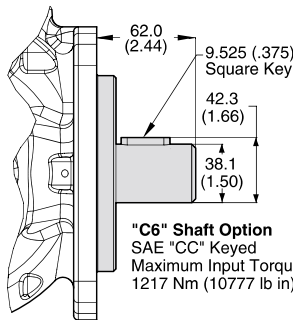

"C6" Shaft Option
 SAE "CC" Keyed
 Maximum Input Torque:
 1217 Nm (10777 lb in)

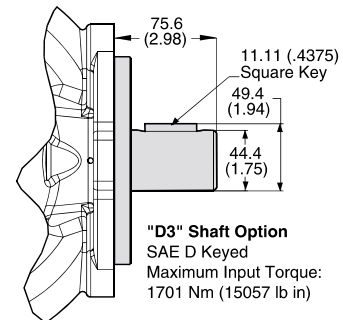

"D3" Shaft Option
 SAE D Keyed
 Maximum Input Torque:
 1701 Nm (15057 lb in)

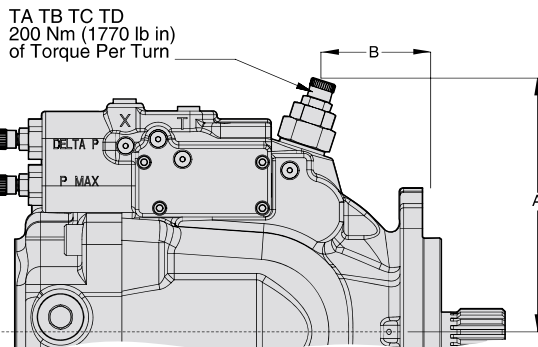

	P3075	P3105	P3145
A	171 (6.73)	190 (7.48)	202 (7.95)
B	69 (2.72)	69 (2.72)	69 (2.72)

Recommended Operating and Installation Instructions

Filtration	For maximum pump and system component life, a fluid contamination level of 19/16/13 per ISO 4406:1999 is recommended. A maximum fluid contamination level of 21/18/14 per ISO 4406:1999 will result in a reduced pump and component life.
Temperature Range	Normal working fluid temperature in tank 0°C - 70°C (+32°F to +158°F) Maximum operating case drain temperature + 90°C (+194°F) Cold start temperature -40°C (-40°F)
Fluid	Premium hydraulic fluid with a normal operating viscosity range between 15 - 40 cSt. Maximum viscosity is 1000 cSt for short periods. Minimum viscosity is 10 cSt for short periods. Oil should have maximum anti-wear properties, rust, and oxidation inhibitors.

Installation Instructions

- When mounting the pump on a system where the fluid level is above the pump inlet (L-shaped or overhead reservoir) the pump case must be full of fluid before starting. This can be accomplished by loosening an inlet gauge port plug or opening the inlet line and allowing gravity to pre-fill the inlet line and case.
When mounting the pump on a system where the fluid level is below the pump inlet (JIC reservoir) the following start-up procedure is recommended. Put approximately 16 ounces of fluid in the pump case to lubricate parts during priming. Remove plug (7/16-20 SAE-4) from air bleed drain port and connect an unrestricted line to tank below minimum fluid level. Start motor and run until pump primes or a maximum of 30 seconds. If pump does not prime in 30 seconds, stop motor (shaft rotating) and repeat until pump primes.
- Do not apply side loads to the pump drive shaft. If side loading is necessary contact your Parker representative.
- Pump and motor shaft alignment must be within .25 millimeters (0.010 inches) TIR using standard floating coupling (no end loading).
- The P2/P3 series of pumps are uni-directional and must be driven in the direction indicated by the arrow on the back of the rear cover.
- Check all inlet connections to be sure they are airtight. An air leak in the inlet line can cause the pump case to drain down and lose prime during succeeding start-ups.
- The pressure compensator is factory set and can be lowered for start-up. Clockwise rotation increases the compensator setting and counter clockwise rotation decrease the compensator setting. Pump compensator should be set with the system deadheaded.
- The differential pressure adjustment and torque control adjustment are factory set - readjustment is not recommended, contact your Parker representative.

P2/P3 Installation Differences

The P3 series pumps are equipped with a control drain, as opposed to a case drain on the P2 series.

Please follow the following instructions for the P3 series.

- The "T" port in the compensator manifold is the control drain and must be connected directly to tank below minimum fluid level. This line should not be combined with other drain or tank lines as back pressure surges could occur causing compensator instability. Back pressure on the control drain will result in an increase in maximum pressure setting.
- An airbleed is standard on P3 series pumps. When required remove airbleed plug (7/16-20 SAE-4) and connect directly to tank below minimum oil level. The airbleed comes in a standard position from the factory but may be relocated for installation requirements. If this is necessary, remove the appropriate plug (1 1/16-12 SAE-12) and install airbleed. The plug must be reinstalled in the port vacated by the airbleed. Both the airbleed and the plug must be torqued to 92 ft-lbs. Not torquing properly can cause o-ring failure.

Please follow the following instructions for the P2 series.

- The case drain line must be connected directly to the tank below fluid level as far away from the inlet line as possible. The case drain line should not be combined with any other drain, return, or suction line as back pressure surges could occur and adversely affect pump performance.



The items described in this document and other documents and descriptions provided by Parker Hannifin Corporation, Hydraulics Group, and its authorized distributors ("Seller") are hereby offered for sale at prices to be established by Seller. This offer and its acceptance by any customer ("Buyer") shall be governed by all of the following Terms and Conditions. Buyer's order for any item described in its document, when communicated to Seller verbally, or in writing, shall constitute acceptance of this offer. All goods or work described will be referred to as "Products".

1. Terms and Conditions. Seller's willingness to offer Products, or accept an order for Products, to or from Buyer is expressly conditioned on Buyer's assent to these Terms and Conditions and to the terms and conditions found on-line at www.parker.com/saleterms/. Seller objects to any contrary or additional term or condition of Buyer's order or any other document issued by Buyer.

2. Price Adjustments; Payments. Prices stated on the reverse side or preceding pages of this document are valid for 30 days. After 30 days, Seller may change prices to reflect any increase in its costs resulting from state, federal or local legislation, price increases from its suppliers, or any change in the rate, charge, or classification of any carrier. The prices stated on the reverse or preceding pages of this document do not include any sales, use, or other taxes unless so stated specifically. Unless otherwise specified by Seller, all prices are F.O.B. Seller's facility, and payment is due 30 days from the date of invoice. After 30 days, Buyer shall pay interest on any unpaid invoices at the rate of 1.5% per month or the maximum allowable rate under applicable law.

3. Delivery Dates; Title and Risk; Shipment. All delivery dates are approximate and Seller shall not be responsible for any damages resulting from any delay. Regardless of the manner of shipment, title to any products and risk of loss or damage shall pass to Buyer upon tender to the carrier at Seller's facility (i.e., when it's on the truck, it's yours). Unless otherwise stated, Seller may exercise its judgment in choosing the carrier and means of delivery. No deferral of shipment at Buyers' request beyond the respective dates indicated will be made except on terms that will indemnify, defend and hold Seller harmless against all loss and additional expense. Buyer shall be responsible for any additional shipping charges incurred by Seller due to Buyer's changes in shipping, product specifications or in accordance with Section 13, herein.

4. Warranty. Seller warrants that the Products sold hereunder shall be free from defects in material or workmanship for a period of eighteen months from the date of delivery to Buyer. The prices charged for Seller's products are based upon the exclusive limited warranty stated above, and upon the following disclaimer: **DISCLAIMER OF WARRANTY: THIS WARRANTY COMPRISES THE SOLE AND ENTIRE WARRANTY PERTAINING TO PRODUCTS PROVIDED HEREUNDER. SELLER DISCLAIMS ALL OTHER WARRANTIES, EXPRESS AND IMPLIED, INCLUDING MERCHANTABILITY AND FITNESS FOR A PARTICULAR PURPOSE.**

5. Claims; Commencement of Actions. Buyer shall promptly inspect all Products upon delivery. No claims for shortages will be allowed unless reported to the Seller within 10 days of delivery. No other claims against Seller will be allowed unless asserted in writing within 60 days after delivery or, in the case of an alleged breach of warranty, within 30 days after the date within the warranty period on which the defect is or should have been discovered by Buyer. Any action based upon breach of this agreement or upon any other claim arising out of this sale (other than an action by Seller for any amount due to Seller from Buyer) must be commenced within thirteen months from the date of tender of delivery by Seller or, for a cause of action based upon an alleged breach of warranty, within thirteen months from the date within the warranty period on which the defect is or should have been discovered by Buyer.

6. LIMITATION OF LIABILITY. UPON NOTIFICATION, SELLER WILL, AT ITS OPTION, REPAIR OR REPLACE A DEFECTIVE PRODUCT, OR REFUND THE PURCHASE PRICE. IN NO EVENT SHALL SELLER BE LIABLE TO BUYER FOR ANY SPECIAL, INDIRECT, INCIDENTAL OR CONSEQUENTIAL DAMAGES ARISING OUT OF, OR AS THE RESULT OF, THE SALE, DELIVERY, NON-DELIVERY, SERVICING, USE OR LOSS OF USE OF THE PRODUCTS OR ANY PART THEREOF, OR FOR ANY CHARGES OR EXPENSES OF ANY NATURE INCURRED WITHOUT SELLER'S WRITTEN CONSENT, EVEN IF SELLER HAS BEEN NEGLIGENT, WHETHER IN CONTRACT, TORT OR OTHER LEGAL THEORY. IN NO EVENT SHALL SELLER'S LIABILITY UNDER ANY CLAIM MADE BY BUYER EXCEED THE PURCHASE PRICE OF THE PRODUCTS.

7. Contingencies. Seller shall not be liable for any default or delay in performance if caused by circumstances beyond the reasonable control of Seller.

8. User Responsibility. The user, through its own analysis and testing, is solely responsible for making the final selection of the system and Product and assuring that all performance, endurance, maintenance, safety and warning requirements of the application are met. The user must analyze all aspects of the application and follow applicable industry standards and Product information. If Seller provides Product or system options, the user is responsible for determining that such data and specifications are suitable and sufficient for all applications and reasonably foreseeable uses of the Products or systems.

9. Loss to Buyer's Property. Any designs, tools, patterns, materials, drawings, confidential information or equipment furnished by Buyer or any other items which become Buyer's property, may be considered obsolete and may be destroyed by Seller after two consecutive years have elapsed without Buyer placing an order for the items which are manufactured using such property. Seller shall not be responsible for any loss or damage to such property while it is in Seller's possession or control.

10. Special Tooling. A tooling charge may be imposed for any special tooling, including without limitation, dies, fixtures, molds and patterns, acquired to manufacture Products. Such special tooling shall be and remain Seller's property notwithstanding payment of any charges by Buyer. In no event will Buyer acquire any interest in apparatus belonging to Seller which is utilized in the manufacture of the Products, even if such apparatus has been specially converted or adapted for such manufacture and notwithstanding any charges paid by Buyer. Unless otherwise agreed, Seller shall have the right to alter, discard or otherwise dispose of any special tooling or other property in its sole discretion at any time.

11. Buyer's Obligation; Rights of Seller. To secure payment of all sums due or otherwise, Seller shall retain a security interest in the goods delivered and this agreement shall be deemed a Security Agreement under the Uniform Commercial Code. Buyer authorizes Seller as its attorney to execute and file on Buyer's behalf all documents Seller deems necessary to perfect its security interest. Seller shall have a security interest in, and lien upon, any property of Buyer in Seller's possession as security for the payment of any amounts owed to Seller by Buyer.

12. Improper Use and Indemnity. Buyer shall indemnify, defend, and hold Seller harmless from any claim, liability, damages, lawsuits, and costs (including attorney fees), whether for personal injury, property damage, patent, trademark or copyright infringement or any other claim, brought by or incurred by Buyer, Buyer's employees, or any other person, arising out of: (a) improper selection, improper application or other misuse of Products purchased by Buyer from Seller; (b) any act or omission, negligent or otherwise, of Buyer; (c) Seller's use of patterns, plans, drawings, or specifications furnished by Buyer to manufacture Product; or (d) Buyer's failure to comply with these terms and conditions. Seller shall not indemnify Buyer under any circumstance except as otherwise provided.

13. Cancellations and Changes. Orders shall not be subject to cancellation or change by Buyer for any reason, except with Seller's written consent and upon terms that will indemnify, defend and hold Seller harmless against all direct, incidental and consequential loss or damage. Seller may change product features, specifications, designs and availability with notice to Buyer.

14. Limitation on Assignment. Buyer may not assign its rights or obligations under this agreement without the prior written consent of Seller.

15. Entire Agreement. This agreement contains the entire agreement between the Buyer and Seller and constitutes the final, complete and exclusive expression of the terms of the agreement. All prior or contemporaneous written or oral agreements or negotiations with respect to the subject matter are herein merged.

16. Waiver and Severability. Failure to enforce any provision of this agreement will not waive that provision nor will any such failure prejudice Seller's right to enforce that provision in the future. Invalidation of any provision of this agreement by legislation or other rule of law shall not invalidate any other provision herein. The remaining provisions of this agreement will remain in full force and effect.

17. Termination. This agreement may be terminated by Seller for any reason and at any time by giving Buyer thirty (30) days written notice of termination. In addition, Seller may by written notice immediately terminate this agreement for the following: (a) Buyer commits a breach of any provision of this agreement (b) the appointment of a trustee, receiver or custodian for all or any part of Buyer's property (c) the filing of a petition for relief in bankruptcy of the other Party on its own behalf, or by a third party (d) an assignment for the benefit of creditors, or (e) the dissolution or liquidation of the Buyer.

18. Governing Law. This agreement and the sale and delivery of all Products hereunder shall be deemed to have taken place in and shall be governed and construed in accordance with the laws of the State of Ohio, as applicable to contracts executed and wholly performed therein and without regard to conflicts of laws principles. Buyer irrevocably agrees and consents to the exclusive jurisdiction and venue of the courts of Cuyahoga County, Ohio with respect to any dispute, controversy or claim arising out of or relating to this agreement. Disputes between the parties shall not be settled by arbitration unless, after a dispute has arisen, both parties expressly agree in writing to arbitrate the dispute.

19. Indemnity for Infringement of Intellectual Property Rights. Seller shall have no liability for infringement of any patents, trademarks, copyrights, trade dress, trade secrets or similar rights except as provided in this Section. Seller will defend and indemnify Buyer against allegations of infringement of U.S. patents, U.S. trademarks, copyrights, trade dress and trade secrets ("Intellectual Property Rights"). Seller will defend at its expense and will pay the cost of any settlement or damages awarded in an action brought against Buyer based on an allegation that a Product sold pursuant to this Agreement infringes the Intellectual Property Rights of a third party. Seller's obligation to defend and indemnify Buyer is contingent on Buyer notifying Seller within ten (10) days after Buyer becomes aware of such allegations of infringement, and Seller having sole control over the defense of any allegations or actions including all negotiations for settlement or compromise. If a Product is subject to a claim that it infringes the Intellectual Property Rights of a third party, Seller may, at its sole expense and option, procure for Buyer the right to continue using the Product, replace or modify the Product so as to make it noninfringing, or offer to accept return of the Product and return the purchase price less a reasonable allowance for depreciation. Notwithstanding the foregoing, Seller shall have no liability for claims of infringement based on information provided by Buyer, or directed to Products delivered hereunder for which the designs are specified in whole or part by Buyer, or infringements resulting from the modification, combination or use in a system of any Product sold hereunder. The foregoing provisions of this Section shall constitute Seller's sole and exclusive liability and Buyer's sole and exclusive remedy for infringement of Intellectual Property Rights.

20. Taxes. Unless otherwise indicated, all prices and charges are exclusive of excise, sales, use, property, occupational or like taxes which may be imposed by any taxing authority upon the manufacture, sale or delivery of Products.

21. Equal Opportunity Clause. For the performance of government contracts and where dollar value of the Products exceed \$10,000, the equal employment opportunity clauses in Executive Order 11246, VEVRAA, and 41 C.F.R. §§ 60-1.4(a), 60-741.5(a), and 60-250.4, are hereby incorporated.



Parker Hannifin Corporation
Hydraulic Pump Division
14249 Industrial Parkway
Marysville, OH 43040 USA
phone 937 644 4435
fax 937 642 3639
www.parker.com