

IQAN-MD5

Instruction book

Publ no MSG33-8419-IB/UK
Edition 2024-10-02



ENGINEERING YOUR SUCCESS.

Publication history

The following table provides an overview of the changes made to this document over the course of its publication history.

Revision / date	Description of change
Rev 001 / 2024-02-21	First version
Rev 002 / 2024-10-02	MD5-10 and MD5-12 info added

Copyright 2024 © Parker-Hannifin Corporation. All rights reserved.

No part of this work may be copied, reproduced, replaced, distributed, published, displayed, modified, or transferred in any form or by any means except with the prior permission of Parker-Hannifin Corporation.

Warning

FAILURE OR IMPROPER SELECTION OR IMPROPER USE OF THE PRODUCTS AND/OR SYSTEMS DESCRIBED HEREIN OR RELATED ITEMS CAN CAUSE DEATH, PERSONAL INJURY AND PROPERTY DAMAGE.

- This document and other information from Parker Hannifin Corporation, its subsidiaries and authorized distributors provide product and/or system options for further investigation by users having technical expertise.
 - The user, through its own analysis and testing, is solely responsible for making the final selection of the system and components and assuring that all performance, endurance, maintenance, safety and warning requirements of the application are met. The user must analyze all aspects of the application, follow applicable industry standards, and follow the information concerning the product in the current product catalog and in any other materials provided from Parker or its subsidiaries or authorized distributors.
 - To the extent that Parker or its subsidiaries or authorized distributors provide component or system options based upon data or specifications provided by the user, the user is responsible for determining that such data and specifications are suitable and sufficient for all applications and reasonably foreseeable uses of the components or systems.
-

Contents

	Publication history	ii
1	Introduction	1
	Warnings	1
2	Precautions	2
	Read This	2
	Start-up, maintenance, and diagnostics	2
3	Product description	3
	IQAN-MD5	3
	System interface	4
	I/O	4
	Digital inputs	4
	Digital outputs	4
	Communication	5
	CAN related functions	5
	IQAN diagnostics bus	5
	Ethernet	5
	HMI (human machine interface)	5
	Display	5
	Markings/Approvals	7
4	Safety	9
	Internal watchdog	9
5	Mounting	10
	Mounting the module	10
	Dashboard or panel assembly	10
	Ball or tilt/swivel mount	10
	Mounting considerations	11
6	Installation	12
	Connector C1	12
	Connector C1 pin assignments	13
	Supply voltage	15
	Wakeup	15
	Connecting of Supply Voltage	15
	Polarity reversal	15
	Addressing	16
	IQAN-MD5 use of an ID-Tag	16
	Identification of an IQAN-MD5 by address	16
	Bypass application	16
	Ethernet diagnostics communication	17
	Video input	17
	Analog Cameras	19
	Diagnostic interfaces	20
	CAN diagnostics connection	20
	Digital out HS 5V	21
	Digital inputs	22
	Connecting switches to the digital inputs	22
	Directional pulse count input	23
	Connecting a directional pulse count channel (DPCNT)	23

Low-side digital outputs	24
Appendix A	25
Appendix B	29
Error messages and actions	29
.....	29
Appendix C	30
IQAN-MD5-5	30
IQAN-MD5-8	31
IQAN-MD5-10	32
IQAN-MD5-12	33

1 Introduction

These instructions are to be used as a reference tool for the vehicle manufacturer's design, production, and service personnel.

The user of these instructions should have basic knowledge in the handling of electronic equipment.

Warnings

Sections marked with a symbol in the left margin, must be read and understood by everyone using the system, carrying out service work, or making changes to hardware and software.

The different symbols used in this manual are defined below.



WARNING

Sections labeled *WARNING* with a caution symbol in the left margin, indicate that a hazardous situation exists. We use warnings, marked with the warning symbol, in two ways.

- As a strong recommendation about work practices when using the product in the machine (e.g. routines when updating an application). This use is common to the term 'hazardous situation', that a person is exposed to a hazard.
- As a way of pointing out important information for the machine designer that in some way relates to safety. This includes the design of the physical machine, and also the application program being developed for the control system.

Not all document sections that contain information about safety are marked with a warning symbol (there would be warnings everywhere). Failure to comply with the recommendations can cause unintentional, and unexpected behavior of the control system. This can potentially cause death, serious injury or property damage.



NOTICE

Sections labeled *NOTICE* with a notice symbol in the left margin, indicate there is important information about the product. Ignoring this could result in less than optimal performance, or damage to the product.

Contact the manufacturer if there is anything you are not sure about or if you have any questions regarding the product and its handling or maintenance.

The term "manufacturer" refers to Parker Hannifin Corporation.

2 Precautions



WARNING

Make sure that you have sufficient knowledge before designing, modifying or servicing the electric system.

Read the relevant sections of this document before conducting any work on the control system.



WARNING

This product is not field repairable.



NOTICE

As much as possible of the welding work on the chassis should be done before the installation of the system. If welding has to be done afterwards, the electrical connections on the system must be disconnected from other equipment. The negative cable must always be disconnected from the battery before disconnecting the positive cable. The ground wire of the welder shall be positioned as close as possible to the place of the welding. The cables on the welding unit shall never be placed near the electrical wires of the control system.

Read This

Start-up, maintenance, and diagnostics

For all personnel carrying out installation, commissioning, maintenance or troubleshooting.

Additional information for diagnosing the system

See "Appendix B" in this document.

Use the IQANrun software user manual as a reference.

3 Product description

IQAN-MD5

The IQAN-MD5 is a family of touch display units, fully compliant with the IQANdesign platform system. The IQAN-MD5 is fully programmable for use in any machine application for primary use as a display in combination with an IQAN-MC4x master in the IQAN ecosystem. The units have full graphical, diagnostic, and CAN gateway capabilities and are used with the easy IQAN programming tools. Together with the multi-master functionality in IQANdesign, it is recommended to use the display in a multi-master machine application

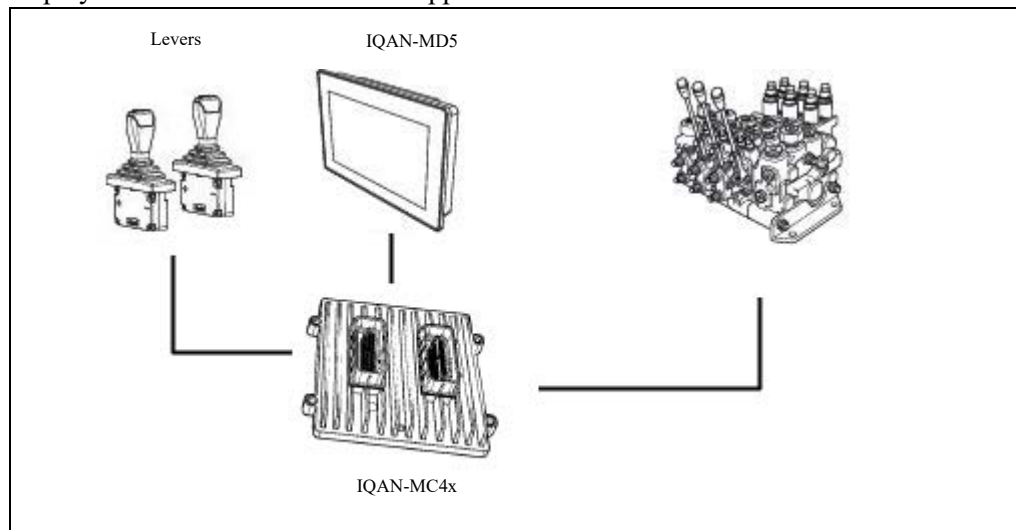

Typical IQAN-MD5 system

System interface

The display modules, IQAN-MD5, is recommended to be used in combination with other IQAN masters to create a multi-master system with the other masters handling all real time critical operations. IQAN-MD5 has three CAN buses and up to two ethernet ports. SAE J1939 and Generic CAN protocols are also supported on the CAN buses and gives the possibility to interface to 3rd party units.

IQAN-MD5 has two directional pulse count inputs and eight digital inputs that are designed to be flexibly configured using IQANdesign software. The unit also has two low side digital outputs and a 5V output.

I/O

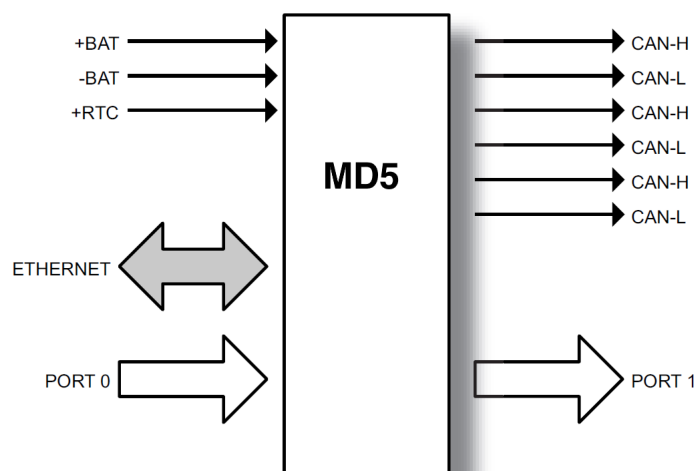

Digital inputs

The IQAN-MD5 module has eight (8) digital inputs DIN-A thru DIN-H.

Digital outputs

The IQAN-MD5 module has three (3) digital outputs DOUT-A thru DOUT-C, one (1) of those are a DOUT-HS-5V and two (2) are DOUT-LS.

Communication

The communication interfaces are used for uploading/downloading applications, connecting to expansion modules, connecting to cameras or diagnostics.

CAN related functions

The IQAN-MD5 uses a CAN-bus (CAN = Controller Area Network) to communicate with other systems. The CAN-bus is a robust communication protocol that is widely used and well proven within the automotive industry.

All versions of the IQAN-MD5 have three(3) CAN buses, CAN-A to CAN-C. The CAN buses may be configured in IQANdesign to be used for IQAN diagnostic and multi-master traffic, SAE J1939 modules (e.g. for engine and transmission), or as Generic bus for user defined CAN protocol (suitable also for CANopen).

CAN FD

The IQAN-MD5-x displays have the option to use CAN FD (flexible data-rate) with speeds up to 500/2000 kbps. The CAN FD protocol allows higher bandwidth and also more storage capacity in the CAN-frame. While classic CAN has the capacity to hold 8 bytes of data within the CAN-frame, CAN FD can hold up to 64.

IQAN diagnostics bus

The IQAN diagnostics bus is used for communication between master units in a multi-master system, and also as a gateway to an IQAN-G12 or to a connected PC (requires compatible USB to CAN adapter).

Ethernet

The MD5 has up to two Ethernet communication ports depending on configuration.

ETH1 is used for uploading/downloading applications and diagnostics and is designated for computer communication. see *Ethernet diagnostics communication* for more information.

ETH2 is used for in-vehicle network over Ethernet, for example communicating with camera. see *Video input* for more information on how to use cameras.

HMI (human machine interface)

Display

Touch function

The IQAN-MD5 display has a capacitive touch screen (PCAP touch screen) enabling the user to control the display with the use of fingers, passive stylus, thin gloves or thicker gloves with conductive material in the finger tips. The touch sensor is protected from wear behind a glass surface.

Scratch resistance

In order to maximize the life cycle of the optical performance of the display, the glass surface does not have any anti-reflection treatment. Such surface treatments have a tendency to mechanically wear down over time and would give a worn out appearance of the display and a reduced optical performance.

Maintenance

Reasonable care should be taken to maintain the glass.

The display can be cleaned with an LCD cleaning solution found in many stores. Use a lightly dampened lint-free, non-abrasive cloth when cleaning the display.



NOTICE

To avoid scratches, do not wipe or clean a dry display.

Water

IQAN-MD5 is a hardened module suitable for both in-cab and outdoor use.

The display will not be damaged by water, but the touch sensor has been tuned to reduce the risk of unintentional activation of buttons from water drops. The touch interface can have limited functionality if an excessive amount of water droplets remain on the screen. If the MD5 display is placed in exposed locations where water spray can hit the display, additional splash protection could be used.



NOTICE

It is recommended to place the display in a vertical position so that water droplets that hit the display roll off the display glass.

Brightness

The brightness is easily adjusted by pressing the 'menu' touch button and following the prompts to the backlight settings section. The backlight is automatically dimmed at supply voltage <math><11\text{V}</math>.

Image persistence

The IQAN-MD5 LCD, like all other LCD screens, can show image persistence, also known as image sticking, if the same pattern is left on the display for extended periods of time.



NOTICE

To avoid the possibility of image sticking in applications where the display is rarely powered down, a screen saver that alters the display image could be used.

Markings/Approvals

The markings/approvals reflect the state of the products at the time of publishing.



Declaration of Conformity

EU

We: Parker Hannifin Manufacturing Sweden AB

Located at: Bruksgatan 20
S-435 35 Mölnlycke, SWEDEN
Tel. +46 31 750 44 00

Declare that the products identified herein comply with the essential requirements of the following EU directives:

2014/30/EU **EU EMC Directive**
2011/65/EU **EU RoHS II Directive**

Harmonized standards:

ISO 14982:2009 Agricultural and forestry machines - Electromagnetic compatibility - Test methods and acceptance criteria

ISO 13766-1:2018 Earth-moving and building construction machinery - Electromagnetic compatibility (EMC) of machines with internal electrical power supply - Part 1: General EMC requirements under typical electromagnetic environmental conditions

EN 50581:2012 Technical documentation for the assessment of electrical and electronic products with respect to the restriction of hazardous substances

Trade Name: Electrohydraulic Control Systems

Products: **IQAN-MD5**

Signature of responsible party: 

Printed name of responsible party: Håkan Jisland
Position of responsible party: Business Unit Manager

Executed on February 19th 2024, Mölnlycke, Sweden



Declaration of Conformity UK

We: Parker Hannifin Manufacturing Sweden AB

Located at: Bruksgatan 20
S-435 35 Mölnlycke, SWEDEN
Tel. +46 31 750 44 00

Declare that the products identified herein comply with the essential requirements of the following UK regulations:

S.I. 2016 No. 1091 Electromagnetic Compatibility Regulations 2016

S.I. 2012 No. 3032 The Restriction of the Use of Certain Hazardous Substances in Electrical and Electronic Equipment Regulations 2012

Designated standards:

ISO 14982:2009 Agricultural and forestry machines - Electromagnetic compatibility - Test methods and acceptance criteria

ISO 13766-1:2018 Earth-moving and building construction machinery - Electromagnetic compatibility (EMC) of machines with internal electrical power supply - Part 1: General EMC requirements under typical electromagnetic environmental conditions

EN 50581:2012 Technical documentation for the assessment of electrical and electronic products with respect to the restriction of hazardous substances

Trade Name: Electrohydraulic Control Systems

Products: IQAN-MD5

Signature of responsible party: 

Printed name of responsible party: Håkan Jisland
Position of responsible party: Business Unit Manager

Executed on February 19th 2024, Mölnlycke, Sweden

4 Safety



WARNING

The IQAN-MD5 is designed for use as a display in a multi master system with the other master handling all real time critical functions. It is not designed for machine control functionality.

Internal watchdog

The module has an internal watchdog that checks if the application is running. If a watchdog timeout is detected, the module is restarted. This watchdog timeout is relatively long and is implemented to keep display functionality, not machine functionality.

5 Mounting

Mounting the module

The IQAN module should be mounted according to the following instructions:

Dashboard or panel assembly

When installing in a dash or panel the recommended panel thickness is 1.0 - 3.5 mm.

Ball or tilt/swivel mount

Different mounting options for ball mounts are integrated in the aluminium heat sink back plate.



Adjustable mounting the IQAN-MD5

See 'Appendix C' for mounting pattern dimensions.

Mounting considerations



NOTICE

IQAN-MD5 shall be positioned in the machine per the following instructions:

- The unit is designed for outdoor use. Position the unit in desired location and make sure that it is not exposed to mechanical damage.
- The connector on the reverse side of the unit should be accessible.
- Position the unit so there is no risk that the cabling can be folded, crushed, worn or damaged in any way.
- Leave sufficient room behind the unit to insert connectors.

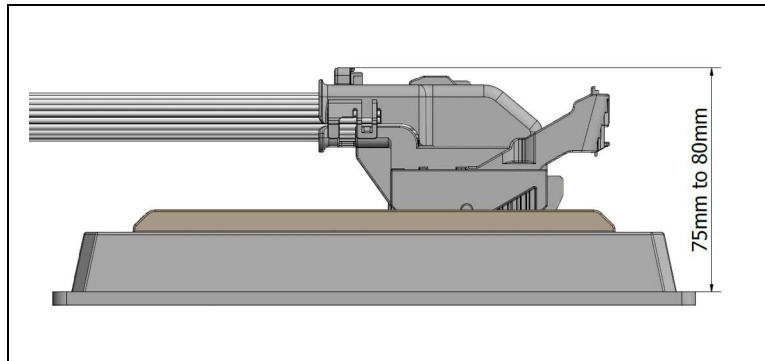

Distance behind the unit.



NOTICE

- Position the unit so there is no risk to be exposed to external heat, e.g. from the engine or heater.
- The best readability will be achieved by positioning the front face of the unit directly towards the operator.
- Extended periods of exposure to direct sunlight can cause an internal temperature exceeding 90°C which may cause permanent degradation of the LCD display.



NOTICE

The connector must be properly installed in the unit.

- If unused wire positions in a connector are not closed with the recommended plugs, the unit will not be sealed.

6 Installation

Connector C1

Connector kit	Parker	C1 (MX123)
Connector	Molex 34576-0703	
Connector (reversed)	Molex 34576-1903	
Pin type	Molex 33467-0024	
Sealing plug	Molex 34586-0001	
Dress cover	Molex 34575-0003	

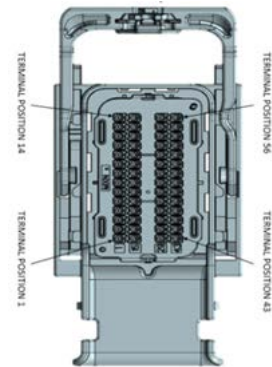

NOTICE

No pin may be "double crimped". That means only one wire may be attached to any given pin. Failure to follow this instruction will cause the module to not meet the environmental specification.

Make "Y" connections or splices using weatherproof methods external to the IQAN-MD5 connector.

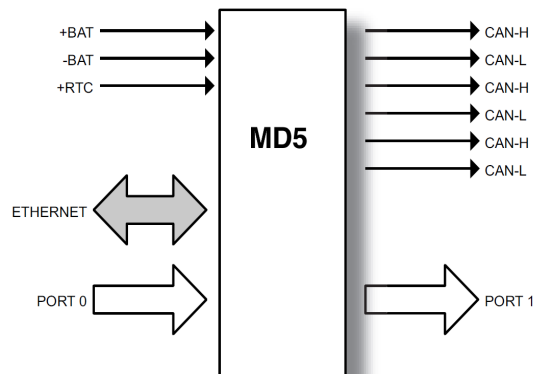

Connector C1 pin assignments

Pin No.	Symbol	Function
C1:1	ETH1-TD-	Ethernet 1 TD-
C1:2	ETH1-RD-	Ethernet 1 RD-
C1:3	-	
C1:4	ETH2-TD-	Ethernet 2 TD- (not available on MD5-5)
C1:5	ETH2-RD-	Ethernet 2 RD- (not available on MD5-5)
C1:6	-	
C1:7	-	
C1:8	-	
C1:9	-	
C1:10	-	
C1:11	DOUT-B (LS)	Digital output low side
C1:12	-BAT	Power supply
C1:13	LWU	(not supported in vmAC 7.02)
C1:14	KEY	(not supported in vmAC 7.02)
C1:15	ETH1-TD+	Ethernet 1 TD+
C1:16	ETH1-RD+	Ethernet 1 RD+
C1:17	-	
C1:18	ETH2-TD+	Ethernet 2 TD+ (not available on MD5-5)
C1:19	ETH2-RD+	Ethernet 2 RD+ (not available on MD5-5)
C1:20	-	
C1:21	-	
C1:22	-	
C1:23	-	
C1:24	-	
C1:25	DOUT-C (LS)	Digital output low side
C1:26	DOUT-A (HS 5V)	+5 Vdc digital output
C1:27	-	
C1:28	+RTC	Real time clock
C1:29	-BAT	Power supply
C1:30	-	
C1:31	ADDR-L	Low side to address tag. Return (0V)

C1:32	CAN-A-L	CAN low, bus 1
C1:33	CAN-A-L	CAN low, bus 1
C1:34	CAN-B-L	CAN low, bus 2
C1:35	CAN-B-L	CAN low, bus 2
C1:36	CAN-C-L	CAN low, bus 3
C1:37	CAN-C-L	CAN low, bus 3
C1:38	DIN-A	Digital input A
C1:39	DIN-B	Digital input B
C1:40	DIN-C	Digital input C
C1:41	DIN-D	Digital input D
C1:42	+BAT	Power supply
C1:43	-BAT	Power supply
C1:44	-	
C1:45	ADDR-H	High side to address tag. Sourcing +5V
C1:46	CAN-A-H	CAN high, bus 1
C1:47	CAN-A-H	CAN high, bus 1
C1:48	CAN-B-H	CAN high, bus 2
C1:49	CAN-B-H	CAN high, bus 2
C1:50	CAN-C-H	CAN high, bus 3
C1:51	CAN-C-H	CAN high, bus 3
C1:52	DIN-E	Digital input E
C1:53	DIN-F	Digital input F
C1:54	DIN-G	Digital input G
C1:55	DIN-H	Digital input H
C1:56	+BAT	Power supply

Supply voltage

Before any installation of the IQAN system can take place, make sure the ignition lock is turned off and the battery is disconnected.

Wakeup

TBD (Wakeup not supported in vmAC 7.02)

Connecting of Supply Voltage

The supply voltage, should be within the operating interval, see Appendix A. Connect the supply voltage to +BAT and -BAT. Protect the module by using a fuse. For recommended fuse level, see Appendix A.

RTC supply

IQAN-MD5 modules have a clock that is used for date/time stamping when logging data. The *real time clock*, +RTC, requires a separate positive power connection. Connect the supply voltage to +RTC through fuse.

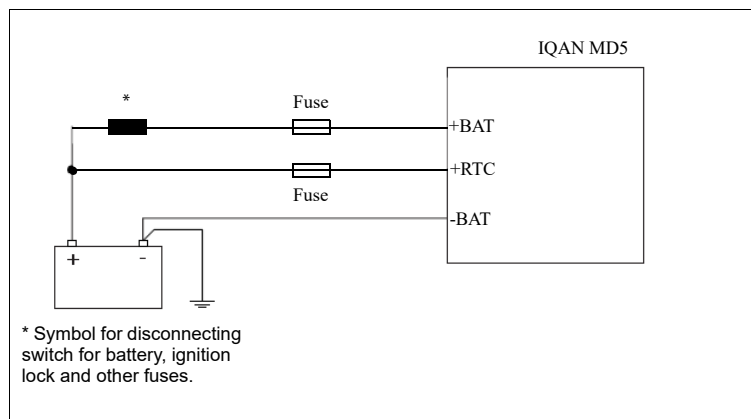

Connecting the RTC and voltage supply.



NOTICE

Do not use the chassis as the negative terminal.

Polarity reversal

The module is protected against power supply polarity reversal and over-voltage, provided an external fuse is being used.

If this fuse is not used, polarity reversal can damage the unit.

Addressing

IQAN-MD5 use of an ID-Tag

In IQANdesign software, more than one IQAN master module can be used together in a multi-master system. The master modules are each given a unique address by using an ID-Tag. The value of the ID-Tag identifies the master and will enable a single project application to be loaded into more than one master module over the CAN bus. The functionality needed for each master is loaded based on the ID-tag address.

Identification of an IQAN-MD5 by address

For normal operation of an IQAN-MD5 in a single master system, the ID-Tag is still used. When no ID-Tag is installed, the MD5 will start in safe mode.

The connection of an ID-Tag between ADDR-H and ADDR-L will assign an address to the IQAN-MD5 master module. The desired functionality based on address is built into the project file using IQANdesign software. For more information, please refer to the IQANdesign user manual. It is the combination of *address* and module *type* that gives each master module a unique identification.

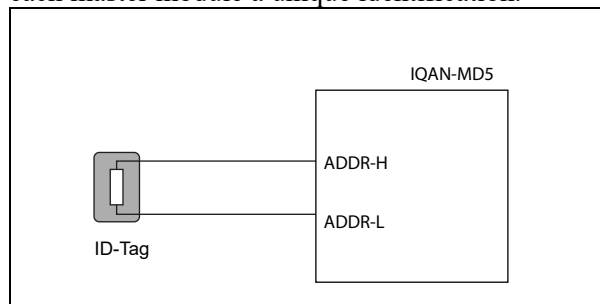

Connecting of ID-Tag.

Bypass application

This is a special start-up mode that is used for master modules and puts the unit in a safe state without starting any application. You may bypass loading the application in the MD5-x on start up in two ways.

- 1 If ADDR_L pin shorted to ADDR_H pin is detected when the module starts (during power up) the application will not be loaded. When starting in a safe state with no application is desired, a jumper is put across pins 31 and 45 on the connector, in place of an ID-Tag.

The MD5-x will also bypass application on start up if the ID-Tag is absent. This is an easier method since you can just remove 1 wire of the ID-Tag.

Ethernet diagnostics communication

The ETH1 Ethernet port is used for diagnostic communication or uploading and downloading project files using IQANdesign/IQANrun. On ETH1, the IP address is automatically assigned using Dynamic IP (DHCP/link-local auto-IP). As an alternative it is also possible to use IQANdesign to configure the IQAN-MD5 application with a static IP address instead.

Video input

The IQAN MD5 master modules are capable of showing video inputs from an external source. For quality images and easy set-up it is recommended to use the IQAN-SV camera. The IQAN-SV is a digital, high resolution IP camera using an Ethernet video link to work together with IQAN-MD5 master displays. All addressing is handled automatically by IQAN software.

- When connecting a video source to the system it is normally Ethernet ETH2 that is used. When using the MD5-5 ETH1 needs to be used as it only have one Ethernet port.

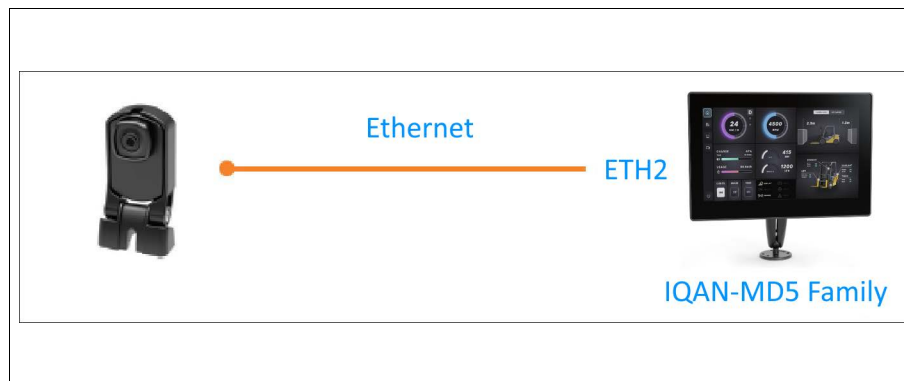

IQAN-SV camera in a system



NOTICE

IQAN-MD5 and the vision system is expandable to 2 camera inputs by also using ETH1.

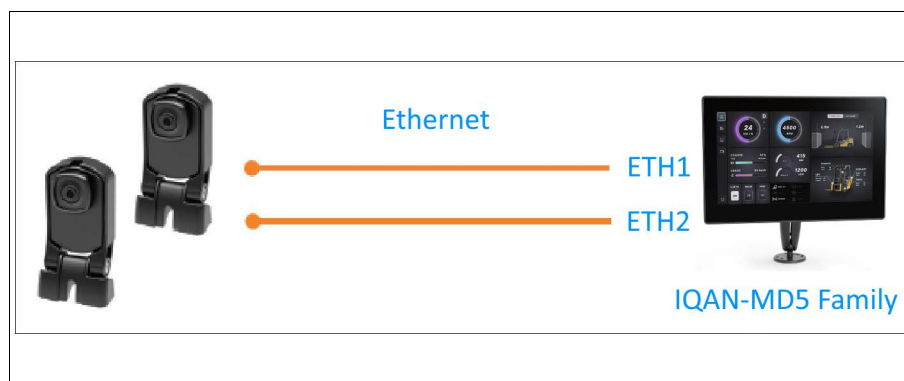

2 x IQAN-SV camera in a system

IQAN-MD5 and the vision system is expandable to a number of cameras by use of an Ethernet switch.

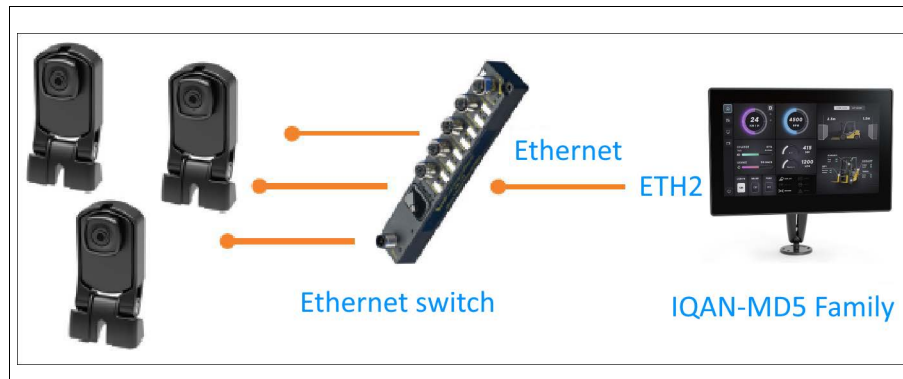

Multiple IQAN-SV cameras in a system

The ETH2 port is dedicated for the in-vehicle network (i.e video input). On port ETH2 when using generic cameras, the MD5 can use DHCP and assign a dynamic address. If you use static IP addresses, the generic camera must have a valid and unique IP address set beforehand in order to be used, see IQANdesign manual for valid IP address range.

For information on how to set the generic camera IP address see the camera manufacturer's instruction book.



NOTICE

The IQAN-MD5 use motion JPEG (MJPEG) as video format when communicating with cameras. The type of signal supported is RTSP (real time streaming protocol). A single camera may be connected directly to the unit.

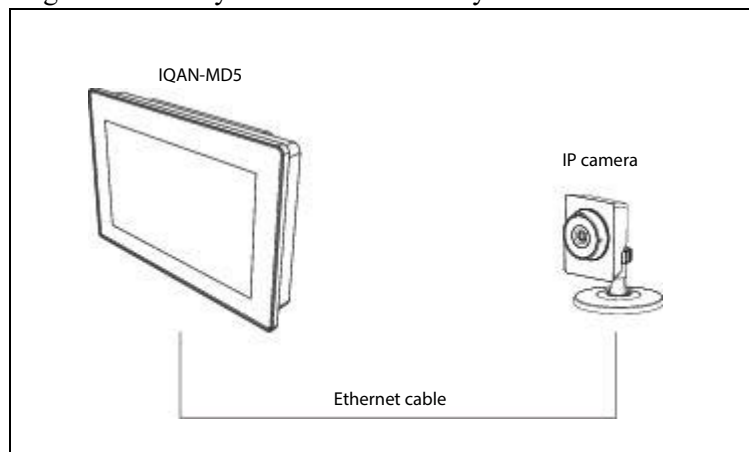

Connecting a camera to the MD5 display.

Using an ethernet switch it is possible to have multiple cameras connected to one MD5 or to have one *static IP address* camera connected to multiple MD5 displays.

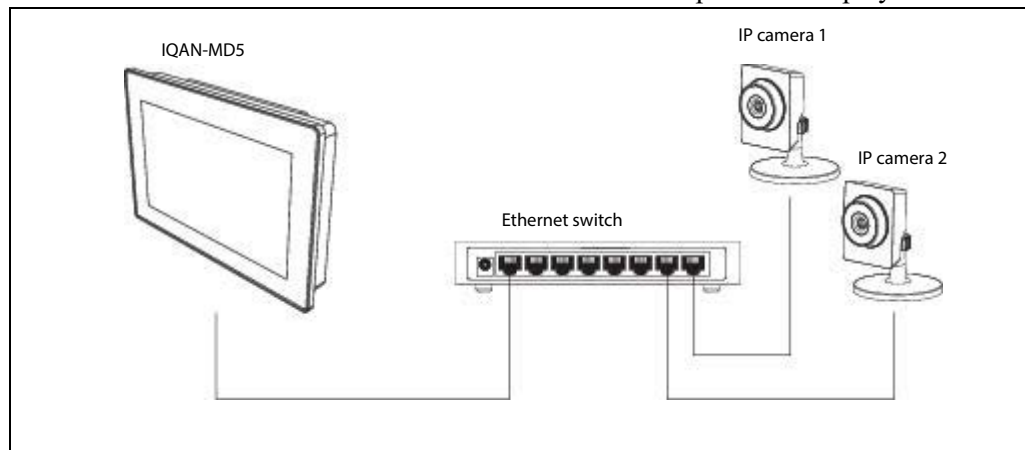

Connecting multiple cameras to one MD5.



NOTICE

When cameras are assigned an IP address using DHCP, their video stream can only be shown on the MD5 that assigned the address to the camera. The other will have a blank video image. A video stream can only be shared with multiple MD5 units from a generic, static IP address camera.

Analog Cameras

It is also possible to connect an analog camera by routing the video feed through a video encoder/server with ethernet connection.

Diagnostic interfaces

IQAN software includes many tools for tuning, measuring, accessing logs and otherwise checking the performance or troubleshooting your control system. To use the diagnostic tools with an IQAN master module you may choose between different ways to connect to the unit.

CAN diagnostics connection

One of the CAN buses of the IQAN master module may be dedicated for diagnostics. Reserving a bus for diagnostics ensures that signals are not interrupted by other bus traffic. A high-speed CAN interface is needed to use this feature. Contact Parker for information about supported CAN interfaces.

A 120 ohm termination resistor is usually required at the CAN interface on the PC. A flying lead cable may be connected to the IQAN master to provide a connector interface. The connection from IQAN master module to diagnostic CAN interface can then be made quite easily. It is recommended that the connector be a sealed, automotive type. When not being used this connector should be protected from the environment with a cover or mating blank plug.

The recommended wiring to the IQAN master module connector is shown below.

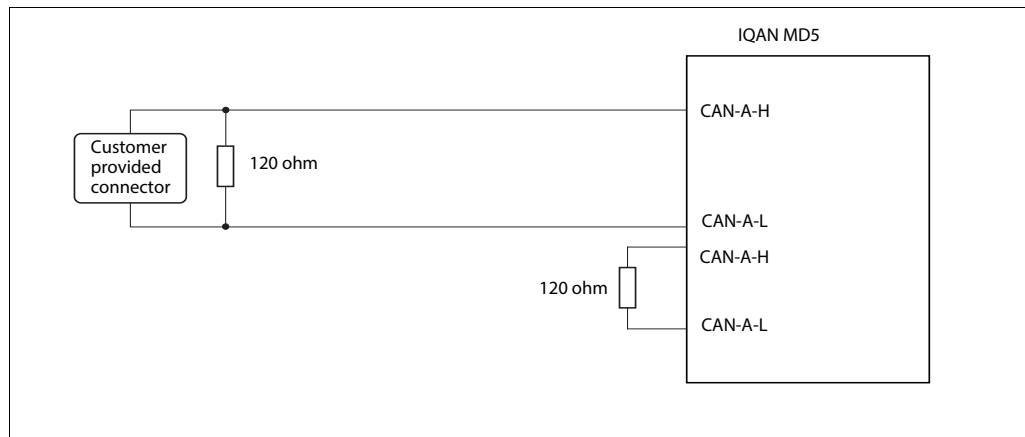

Example of connecting for CAN communication.



NOTICE

The IQAN-MD5 modules does not have any internal termination resistor for the CAN buses. An external resistor is needed if the CAN buses is to be terminated. This is made easier by having dual pins for all CAN buses.

Digital out HS 5V

The IQAN-MD5 family is equipped with a 5 voltage digital output. This output can be used to feed different kinds of sensors and potentiometers.

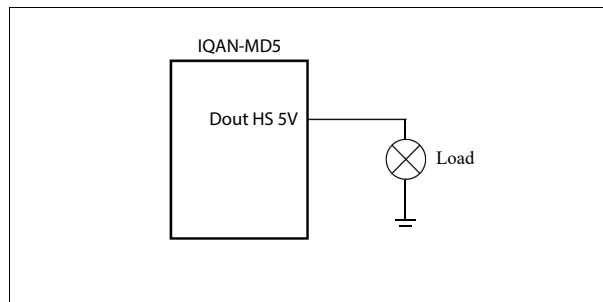

Dout HS 5V.



NOTICE

Maximum load for the *Dout* is different according to 12/24 Vdc power supply, see "Appendix A".

Digital inputs

Connecting switches to the digital inputs

You can safely connect using DOUT HS 5V for the supply.

EXAMPLE

Connect the supply of the switch to DOUT HS 5V, and the signal to DIN-X, respectively.

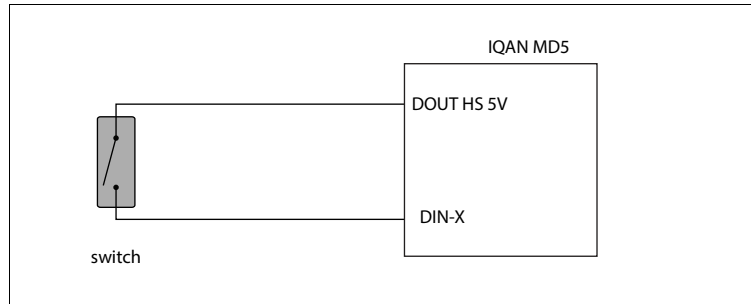

Connecting a switch to DOUT HS 5V and DIN-X.

EXAMPLE

Alternatively one terminal of the switch is connected to the +BAT position and the other terminal is connected to an appropriate digital input DIN position.

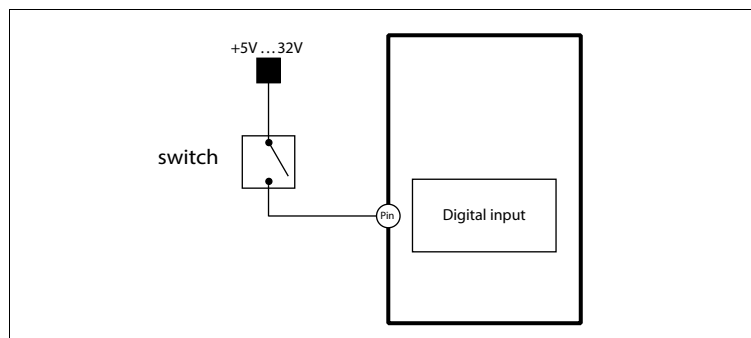

Connecting a switch to +BAT and DIN-X.

Directional pulse count input

Connecting a directional pulse count channel (DPCNT)

The DPCNT is a physical analog input. The directional pulse count input channel is used to count pulses. It is bi-directional, which means it can add and subtract pulses.

The DPCNT is primarily designed for input from an encoder wheel. For maximum frequency, see Appendix A. (DPCNT not supported in vmAC 7.02)

Simple directional pulse count sensor

The positive terminal of the directional pulse count sensor is connected to the 5V DOUT and the negative terminal to the GND respectively. The sensor signals are connected to the DPCNT+ and DPCNT- positions.

EXAMPLE

Connect the positive and negative terminals of the frequency sensor to +VREF and -VREF, respectively. Then connect the sensor signals to DPCNT+ and DPCNT-.

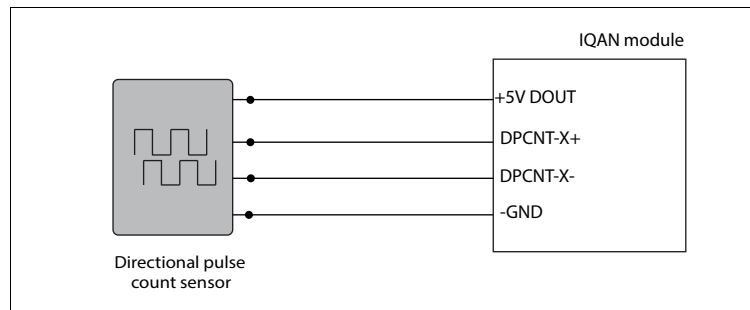

Connecting of directional frequency sensor to DFIN+ and DFIN-.

Low-side digital outputs

The low-side digital outputs are designed to drive small loads, e.g. LED lamps, relays and buzzers. Low-side digital outputs work by grounding a signal through the module. See Appendix A for maximum loads per output.

EXAMPLE

Connect the lamp to the low-side digital outputs using a DOUT(LS) position, and the +BAT, as supply.

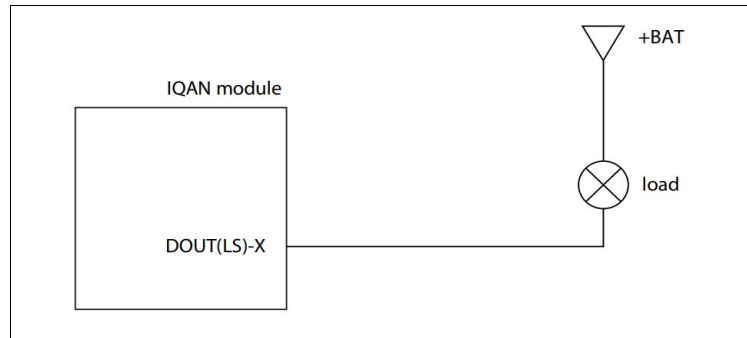

Connecting a switch to DOUT(LS) and +BAT.

Appendix A

IQAN-MD5 Technical Overview

System

$T_A = -30$ to $+70$ °C, unless otherwise specified

Temperature Operating temperature Absolute maximum temperature Storage temperature	-30 to 70 °C -40 to 80 °C -40 to 90 °C
Voltage supply on +BAT, V_{BAT} Power-on/off threshold Over voltage on +BAT Reverse polarity protection on +BAT LCD backlight Short circuit protection	9 to 32 V On 6.1 V (typ.), Off 4.5V (typ.) 36 V with external 20A fuse LCD backlight dimmed below 11V Short to -BAT and +BAT protected on all pins
Current supply - operation -MD5-5, $V_{BAT} = 14V$ -MD5-5 $V_{BAT} = 28V$ -MD5-8, $V_{BAT} = 14V$ -MD5-8 $V_{BAT} = 28V$ -MD5-10 $V_{BAT} = 14V$ -MD5-10 $V_{BAT} = 28V$ -MD5-12, $V_{BAT} = 14V$ -MD5-12 $V_{BAT} = 28V$	typ. 340 mA typ. 180 mA typ. 790 mA typ. 410 mA typ. 785 mA typ. 430 mA typ. 927 mA typ. 485 mA
Current supply - standby $V_{BAT} = 14V$ $V_{BAT} = 28V$	typ. TBD mA typ. TBD mA
Current supply - RTC $V_{BAT} = 14V$ $V_{BAT} = 28V$	typ. 0.9 mA typ. 2.1 mA
Real time clock Backup time 25 °C Accuracy -30/+70 °C	min. 10 days ± 12 sec per day
Dimensions MD5-5 MD5-8 MD5-10 MD5-12	140 x 102 x 43mm 215 x 141 x 44 mm 252 x 173 x 44 mm 329 x 147 x 45 mm
Weight MD5-5 MD5-8 MD5-10 MD5-12	430g 750g 1000 g 1150 g
Start-up time Embedded functions HMI running	tbc s tbc s
System cycle time, T_{SC}	50 ms to 100 ms
Embedded Flash memory	8 GB
Embedded RAM memory	512 MB
Data log memory	64 MB

Markings / Approvals

Climate environment Enclosure, water & dust protection Salt mist Damp heat cyclic Damp heat steady state Heat, operation Heat, storage Cold Change of temperature	ISO 20653-2013, IP65 IEC 60068-2-52:2017 Kb, 72 h EN 60068-2-30:2005 Db, +55°C, 95% RH, 6 cycles IEC 60068-2-78:2001 Cab, +40°C, 93% RH, 21 days IEC 60068-2-2:2007 Bb, +70°C, 72 hours IEC 60068-2-2:2007 Bb, +85°C, 240 hours IEC 60068-2-1:2007 Ab, -30°C, 16 hours EN 60068-2-14:2009 Nb, - 30°C to +70°C, 100 x 4 hours
Mechanical environment Random vibration Bump	IEC 60068-2-64: 2008 Fh, 15 - 1000 Hz, 5.9 Grms, 3 x 20 h IEC 60068-2-27:2008 Ea, 40 g, 6 ms, 1000 * 6 dir
EMC Radiated emission Conducted susceptibility Radiated susceptibility Conducted transients susceptibility Power supply ramp ESD, Operation ESD, Handling	EN ISO 13766:2018/ISO 14982:2009 ISO 11452-4:2011, 1 - 200 MHz, 1 kHz, 80% AM, 150 mA ISO 11452-2:2004, 200-2000 MHz, 1kHz, 80% AM, 100 V/m ISO 11452-2:2004, 800-2000 MHz, PM 577 us / 4.6 ms, 60 V/m ISO 7637-2:2011, Pulse 1, 2a, 2b, 3a, 3b, 4, 5, Level 3; ISO 7637-3:2016, Level 3 SAE J1455:2011, Section 4.13.1 ISO 10605:2008, 8 kV (contact), 25 kV (air) ISO 10605:2008, 8 kV (contact)

LCM - MD5-5 (5 inch)

Resolution	800 x 480 dots
Number of Colors	16.7 M
Active area	108 x 65 mm
Viewing angle	85 degree all directions
Contrast Ratio	800
Maximum allowed dot-defect (1 dot / 2 adj. dot)	Bright dot 4/1, Dark dot 5/2
LED Backlight brightness	700 cd/m ² (typ)
Touch sensor	PCAP
Ambient light sensor	yes

LCM - MD5-8 (8 inch)

Resolution	1280 x 720 dots
Number of Colors	16.7 M
Active area	177 x 99 mm
Viewing angle	85 degree all directions
Contrast Ratio	800
Maximum allowed dot-defect (1 dot / 2 adj. dot)	Bright dot 4/1, Dark dot 5/2
LED Backlight brightness	900 cd/m ² (typ)
Touch sensor	PCAP
Ambient light sensor	yes

LCM - MD5-10 (10 inch)

Resolution	1280 x 800 dots
Number of Colors	16.7 M

LCM - MD5-10 (10 inch)

Active area	217 x 135 mm
Viewing angle	85 degree all directions
Contrast Ratio	800
Maximum allowed dot-defect (1 dot / 2 adj. dot)	Bright dot 4/1, Dark dot 5/2
LED Backlight brightness	900 cd/m2 (typ.)
Touch sensor	PCAP
Ambient light sensor	yes

LCM - MD5-12 (12 inch)

Resolution	1920 x 720 dots
Number of Colors	16.7 M
Active area	292 x 110 mm
Viewing angle	85 degree all directions
Contrast Ratio	800
Maximum allowed dot-defect (1 dot / 2 adj. dot)	Bright dot 4/1, Dark dot 5/2
LED Backlight brightness	900 cd/m ² (typ)
Touch sensor	PCAP
Ambient light sensor	yes

Signal input - DIN

Number of DIN	8 (configuration may reduce number)
Logic levels low high hysteresis	<0.5 V >3 V >150 mV
Input impedance	12 kohm
Sample rate	Same as system cycle time TSC
Maximum continuous voltage	32 V
Diagnostics	defined in application

Signal input - DPCNT

Number of DPCNT	2 (configuration may reduce number) (DPCNT not supported in vmAC 7.02)
Frequency range	0 to 500 Hz, 50/50 signal
Minimum pulse width	1 ms
Logic levels low high hysteresis	<0.5 V >3 V >150 mV
Input impedance	12 kohm
Maximum continuous voltage	32 V
Diagnostics	defined in application

Signal input - LWU

Number of LWU	1 (Wakeup not supported in vmAC 7.02)
Wakeup function	TBD
Logic levels low high hysteresis	<0.5 V >3 V >150 mV
Input impedance	12 kohm
Maximum continuous voltage	32 V

Power driver - DOUT 5V

Number of DOUT	1
Output voltage Load 25 mA Load 150 mA	5.0 V no load < 100 mV voltage drop < 350 mV voltage drop
Maximum load	150 mA
Minimum load	200 uA
Leakage current in OFF state	< 50uA
Protection	overload, SCB, SCG
Diagnostics	No

Power driver - DOUT Low-Side

Number of DOUT	2
Maximum load	300 mA
Minimum load	400 uA
Leakage current in OFF state	< 100uA
Protection	overload, SCB, SCG
Diagnostics	No

CAN

Number of CAN buses	3
CAN Physical layer	High-Speed CAN, Flexible Data Rate
Max baud rate	2Mbit/s
Signal Improvement Capability (SIC)	Yes
Protection	SCB, SCG

Ethernet

Number of Ethernet ports MD5-5 all other variants	PC interface on port A only 1 2
Network interface	100 Base-TX, 10 Base-T, Auto-MDIX (auto crossover)
Network protocol	TCP/IP, UDP, DHCP
Communication rates	10/100 Mbps, auto-negotiated
Streaming video Video format Video resolution	Motion JPEG (MJPEG) limited by screen resolution

Approvals

CE	2014/30/EU, EMC directive 2011/65/EU, RoHS 2, 2015/863 RoHS 2 amendment
UKCA	EMC regulation 2016 RoHS regulation 2012
E-mark	Approval number E5 10 R06 - 0578

Mechanical characteristics

Connector	56 pin Molex MX123
-----------	--------------------

Appendix B

Error messages and actions

If a fault is detected, a message will be presented on the display. A message will also be presented if another master in the system detects a fault.



WARNING

An error message could indicate that a hazardous situation exists. If precautions are not taken, this could result in death, serious injury or major property damage.

Appendix C

IQAN-MD5-5

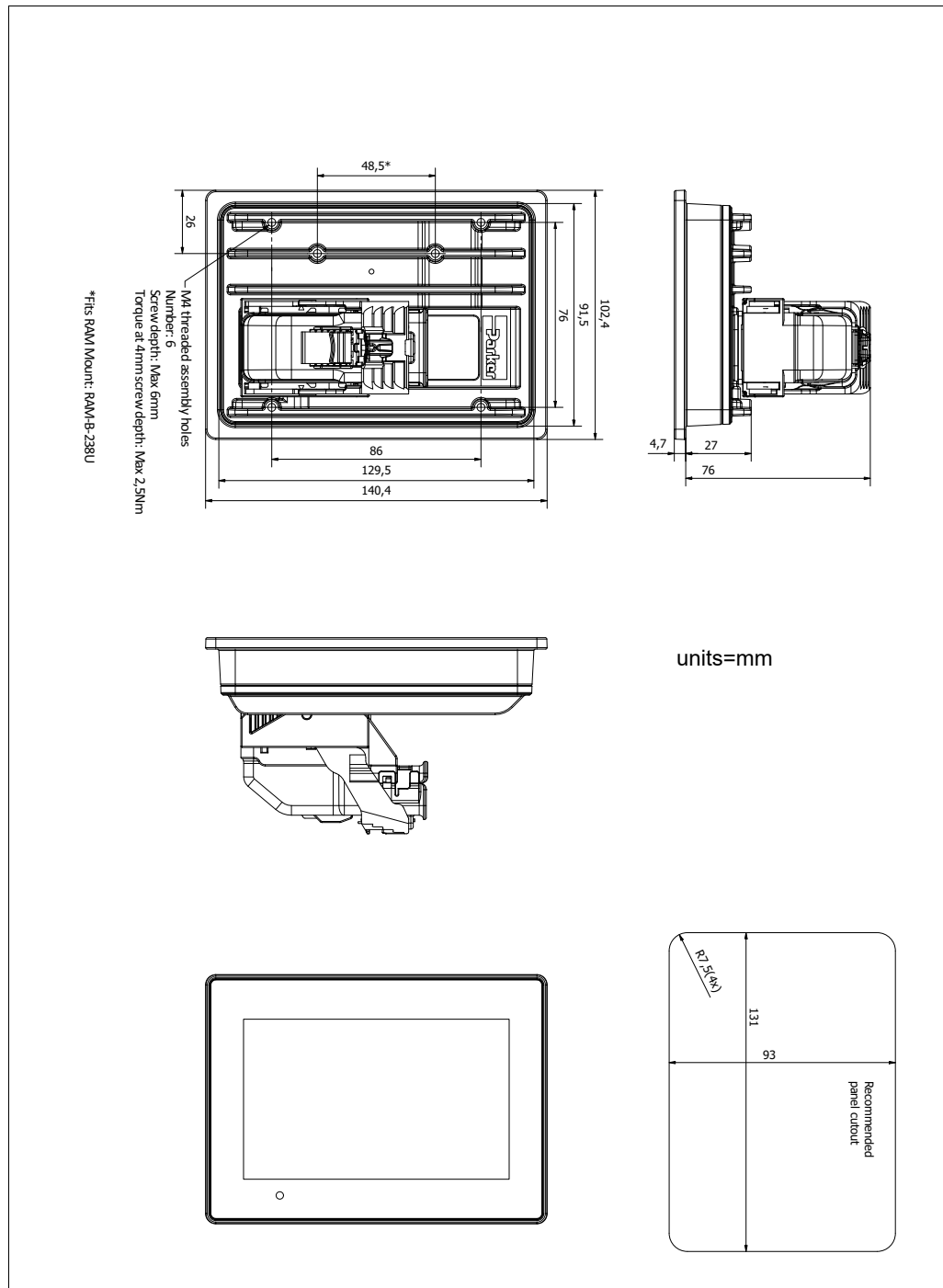

IQAN-MD5-8

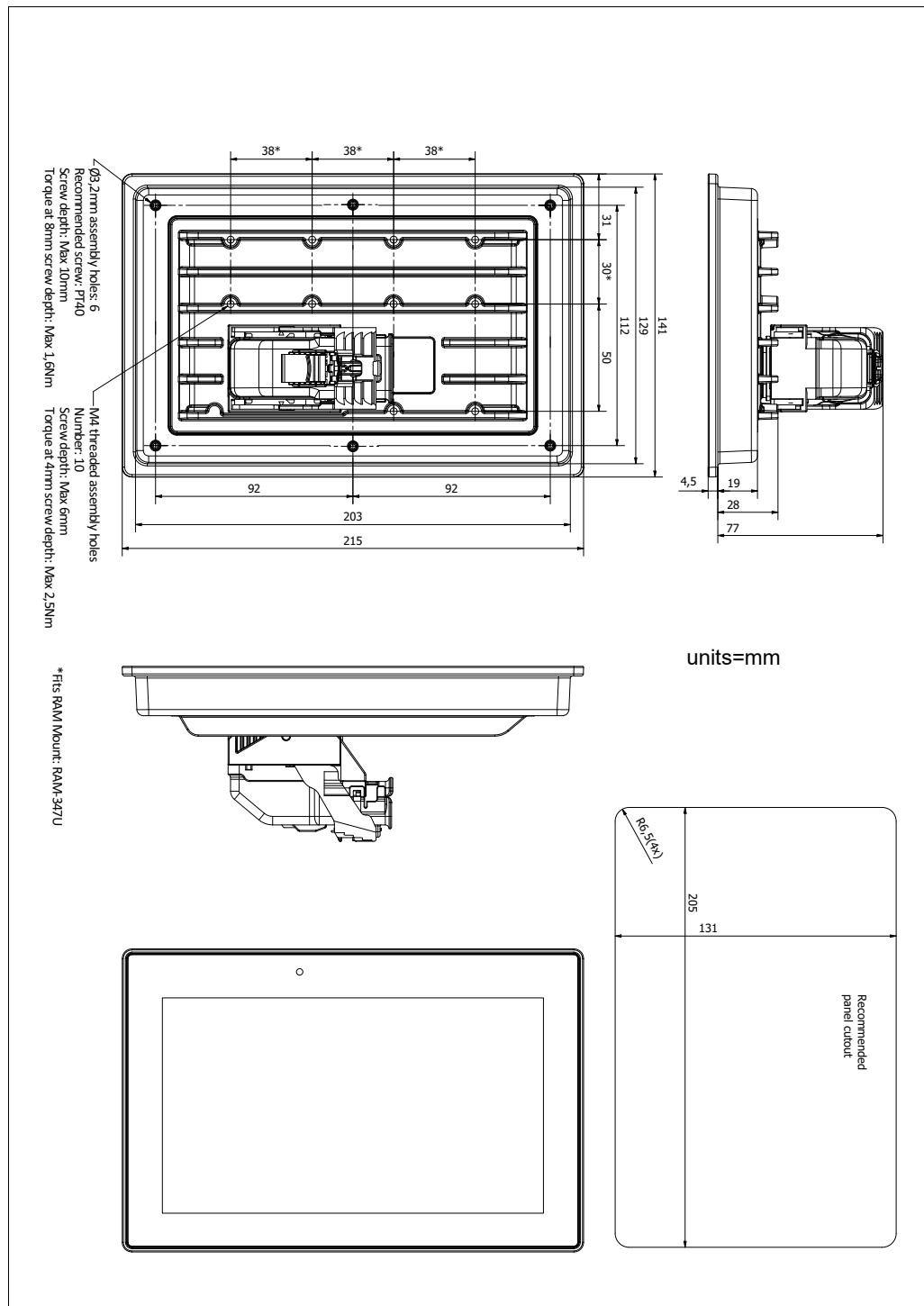

IQAN-MD5-10

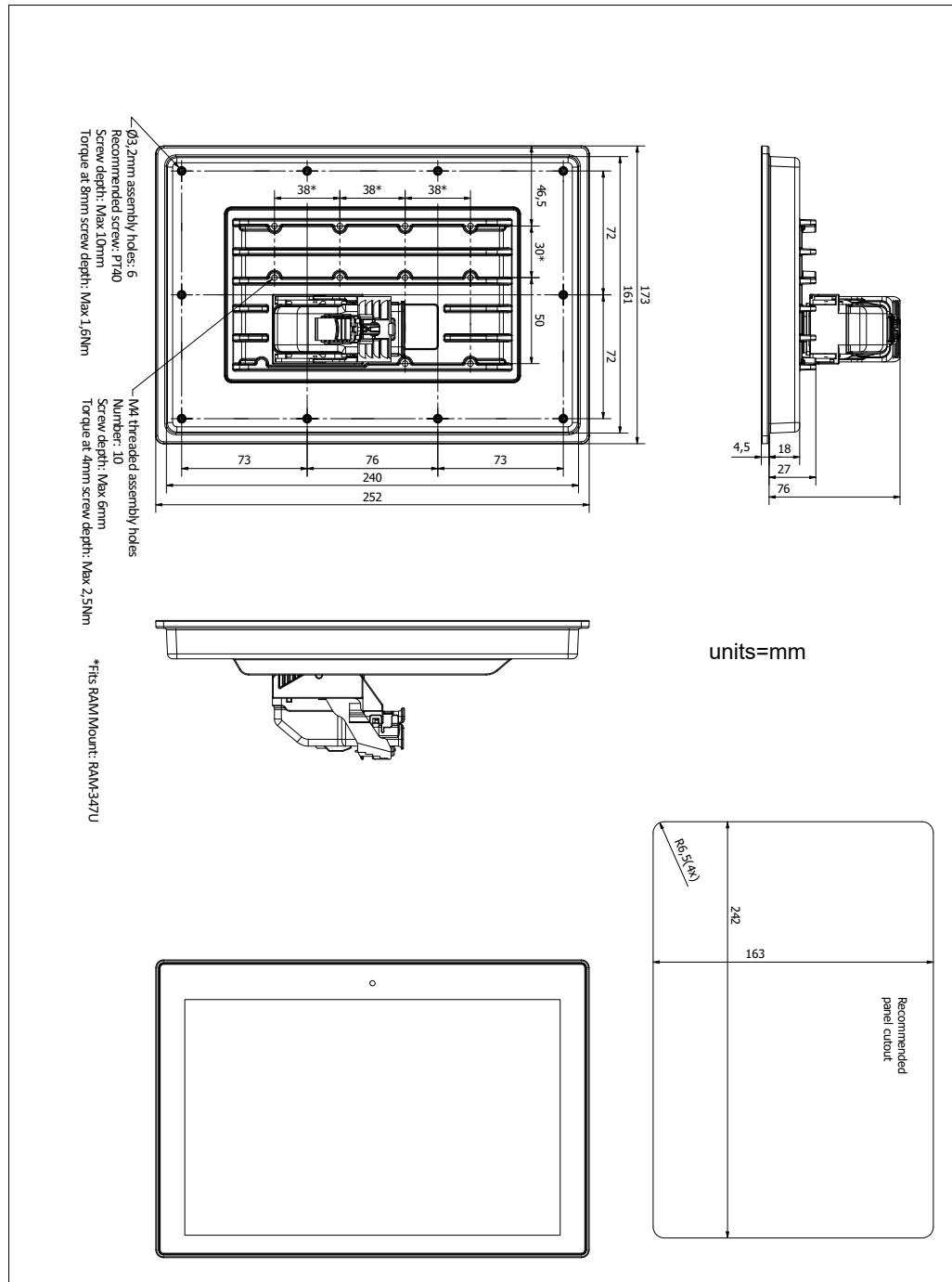

IQAN-MD5-12

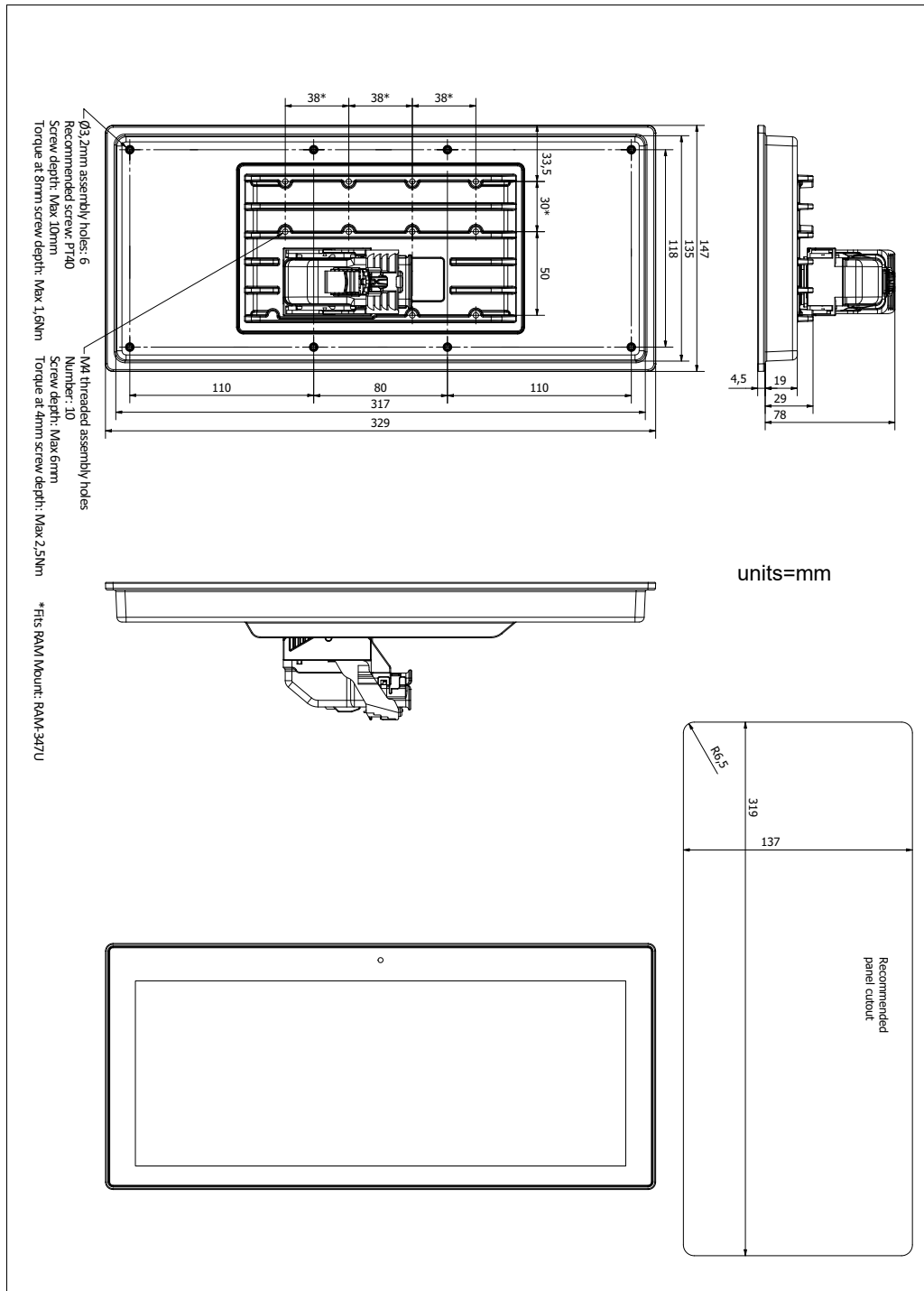

For latest information visit our website www.iqan.com

Information in this instructionbook is subject to change without notice

Publ no MSG33-8419-IB/UK
Edition 2024-10-02

Parker Hannifin
Electronic Motion and
Controls Division Europe
SE-435 35 Mölnlycke
Sweden
Tel +46 31 750 44 00
www.parker.com

Parker Hannifin
Electronic Motion and
Controls Division
1651 N. Main Street
Morton, IL 61550
USA
Tel +1 309 263 7788
Fax +1 309 266 6674

