

± 40 MM
± 1.575 INCHES OF ADJUSTMENT

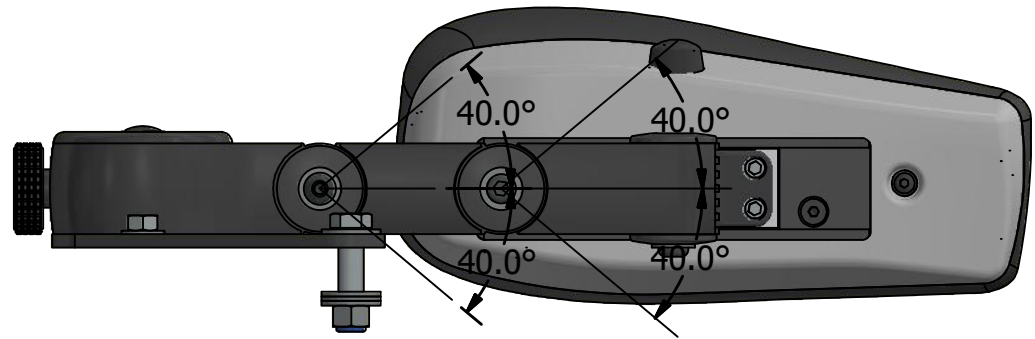

- 3 AXIS OF MOVEMENT ARMREST ASSEMBLY
- AVAILABLE IN BOTH LEFT AND RIGHT CONFIGURATIONS

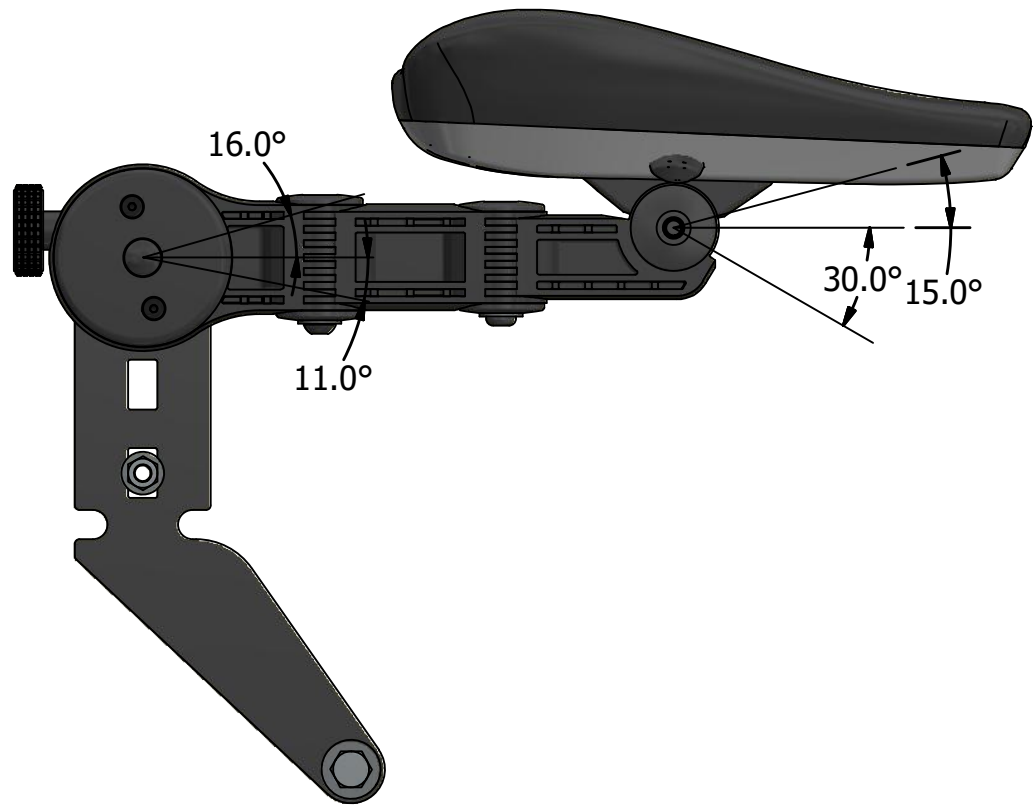
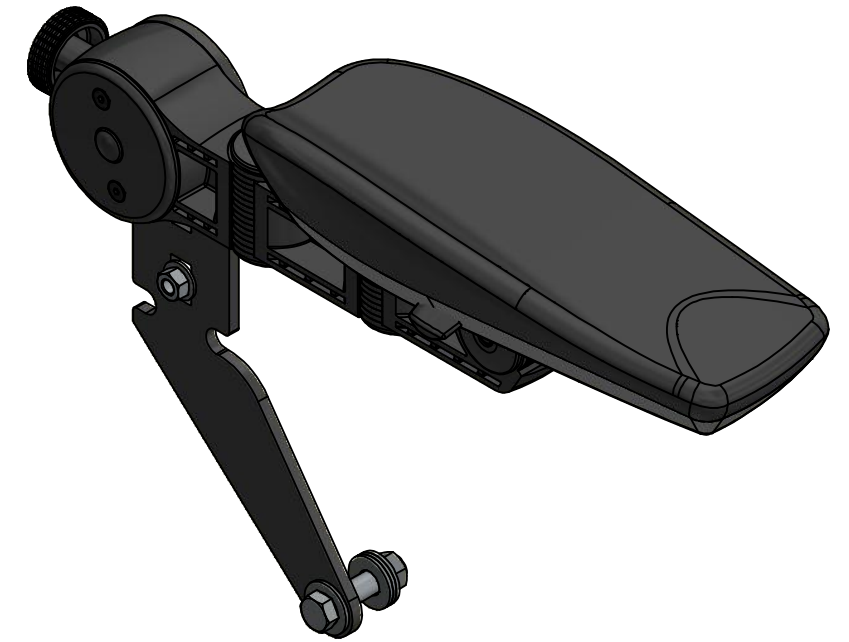

UNLESS OTHERWISE SPECIFIED DIMENSIONS ARE IN INCHES			ORIGINATED BY: KJOHNSON	 GLOBAL RESOURCES MUKWONAGO, WI 53149
WIRE LENGTH TOLERANCES SPEC= IPC/WHMA-A-620B			ORIGINATION DATE: 8-7-2019	
≤ 1ft	+1in -0in	THIRD ANGLE PROJECTION	PROJECT ENGINEER:	DRAWING TITLE: ARMFLEX GF 620 RIGHT ARM
> 1ft-5ft	+2in -0in		ACCOUNT MANAGER:	SHT SIZE: DRAWING NUMBER: REV: A
> 5ft-10ft	+4in -0in		MATERIAL:	B GS19090-027
> 10ft-25ft	+6in -0in		COATING/PLATING:	SCALE: 3:10
> 25ft	+5% -0%		CUSTOMER PART NUMBER:	SHEET INFO: 1 OF 1
FRACTIONS ± 1/16in ± 1.59mm			ALL TECHNICAL DATA ON THIS DRAWING IS THE PROPERTY OF GS GLOBAL RESOURCES INC. AND SHALL NOT BE USED BY OTHERS FOR MANUFACTURE, PROCUREMENT, OR DISCLOSURE WITHOUT THE WRITTEN PERMISSION OF GS GLOBAL RESOURCES INC.	
- TOLERANCES ON DECIMALS:			DRAWING REFERENCE:	
1 PLACE	2 PLACE	3 PLACE		
in ± .030	± .010	± .005		
mm ± .76	± .25	± .13		
- ANGULAR DIMENSIONS ± 1 DEG				
- REMOVE BURRS				
- BREAK EDGES 0.01in 0.25mm MAX				
- MAX SURFACE ROUGHNESS 12.5				

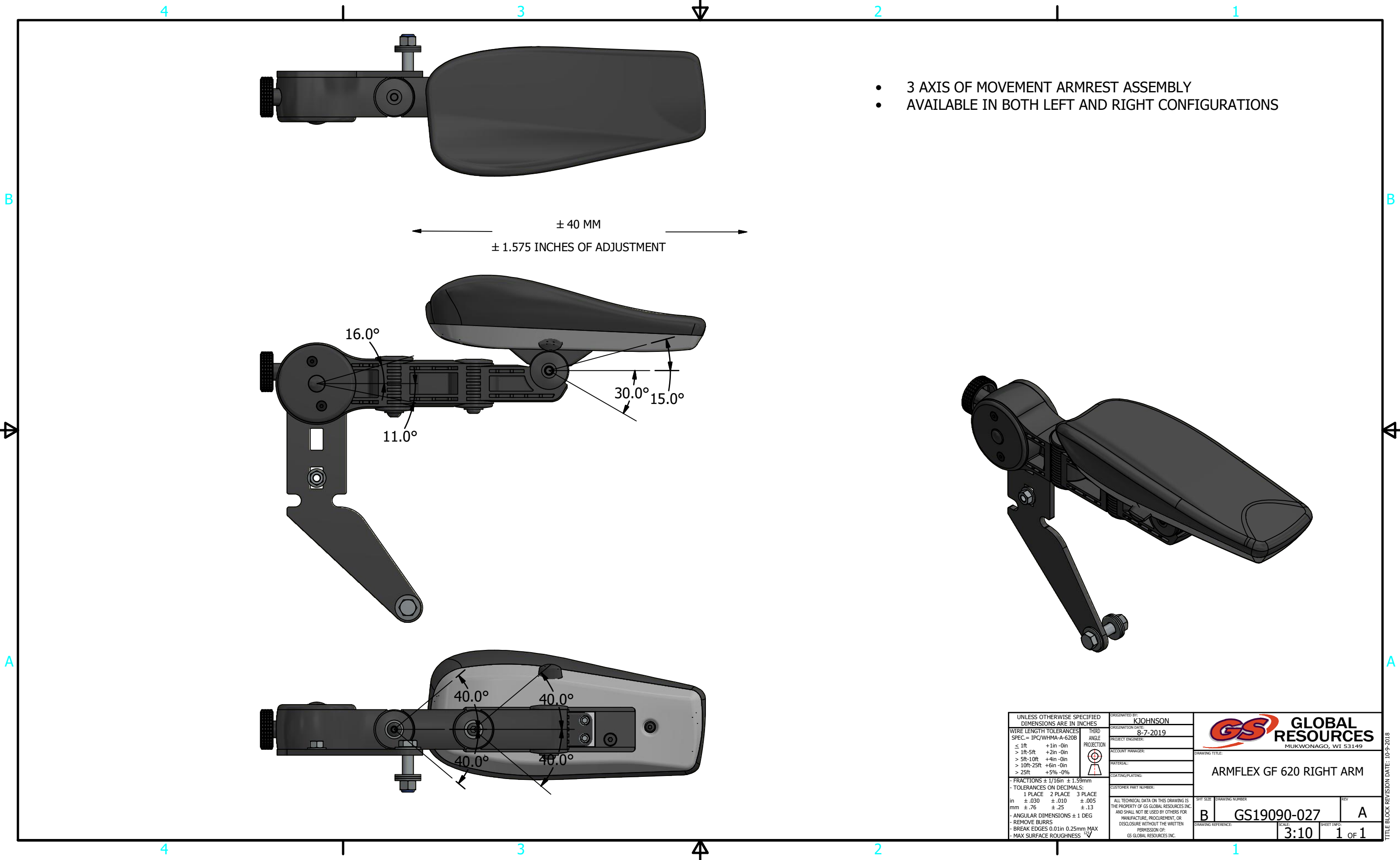

TITLE BLOCK REVISION DATE: 10-9-2018