

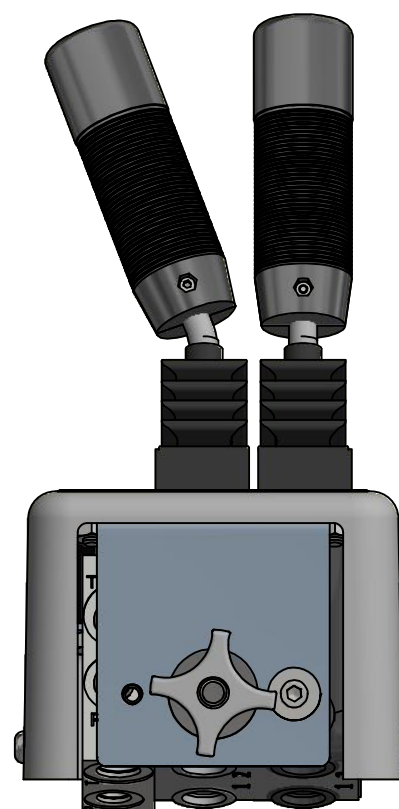

SCALE 1:2

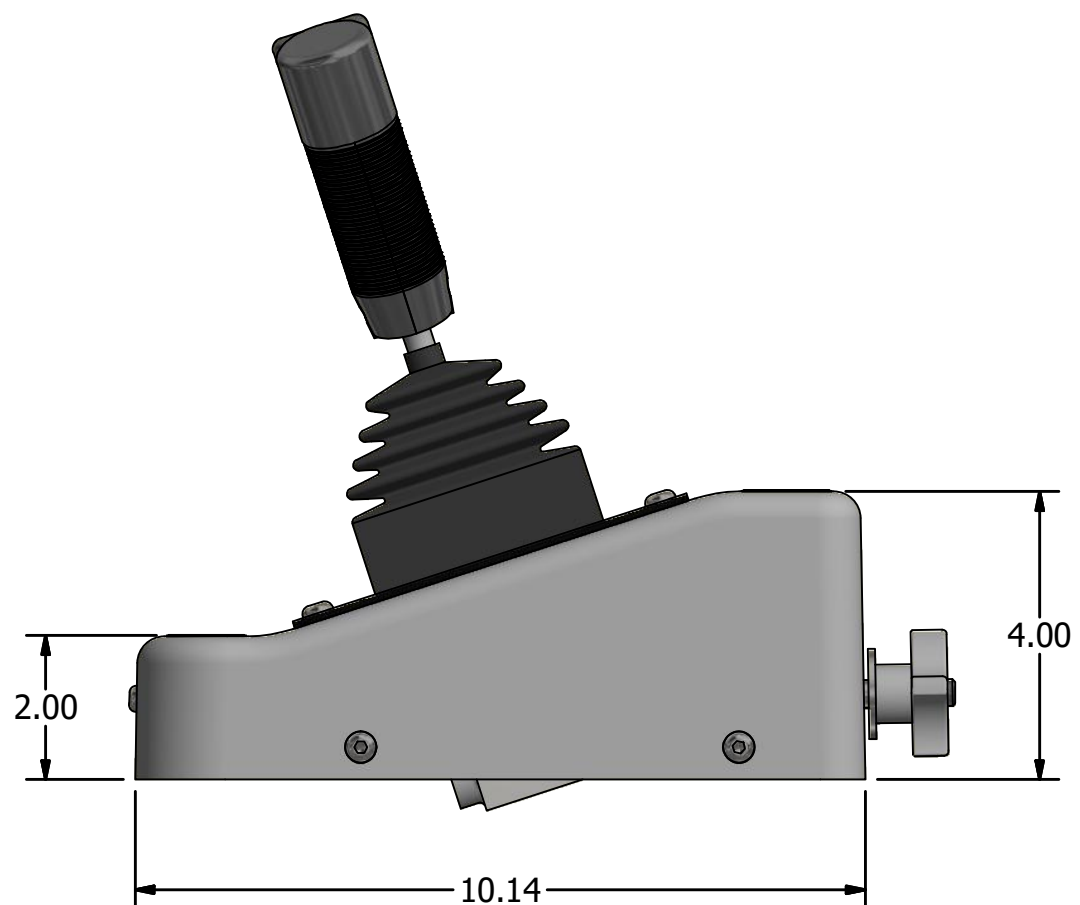
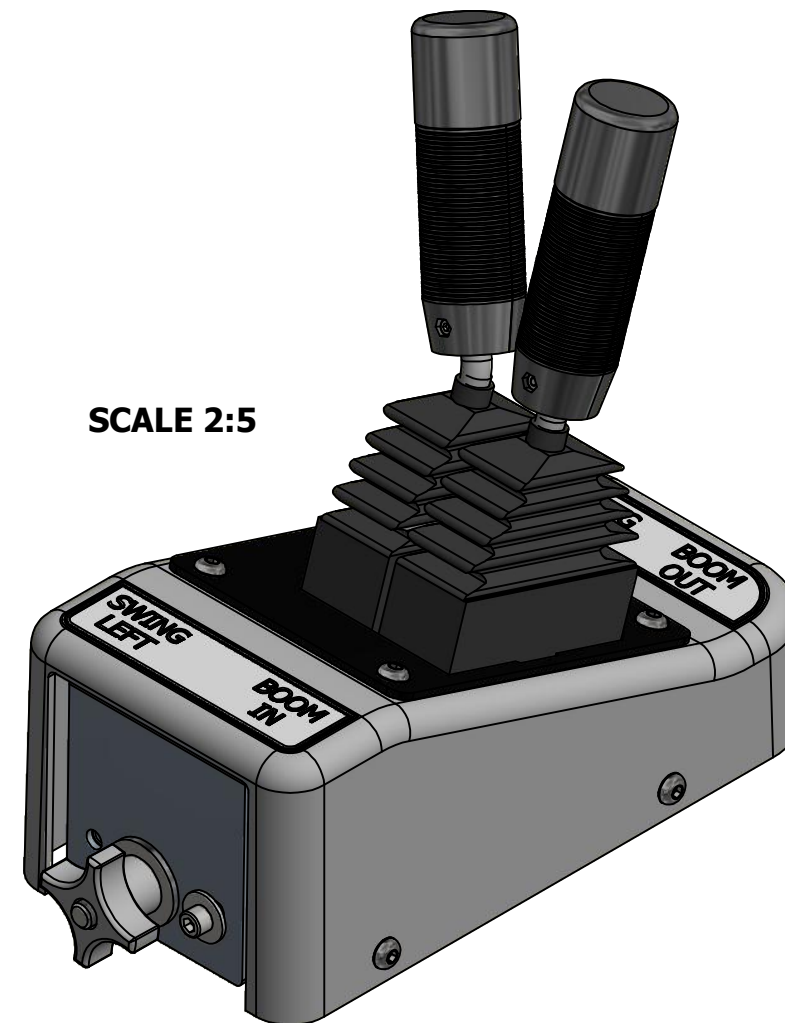

- ADJUSTABLE TILT AND HEIGHT
- THUMPER IN JOYSTICK HANDLE
- CUSTOM MOLDED PLASTIC

SCALE 2:5



UNLESS OTHERWISE SPECIFIED DIMENSIONS ARE IN INCHES		ORIGINATED BY: KJOHNSON	 <p>GLOBAL RESOURCES MUKWONAGO, WI 53149</p>
WIRE LENGTH TOLERANCES SPEC = IPC/WHMA-A-620B		ORIGINATION DATE: 7-16-2019	
≤ 1ft	+1in -0in	PROJECT ENGINEER:	DRAWING TITLE: LEFT POD WITH TWO HYDRAULIC JOYSTICKS
> 1ft-5ft	+2in -0in	ACCOUNT MANAGER:	
> 5ft-10ft	+4in -0in	MATERIAL:	SHEET SIZE: B DRAWING NUMBER: GS19090-009 REV: A
> 10ft-25ft	+6in -0in	COATING/PLATING:	
> 25ft	+5% -0%	CUSTOMER PART NUMBER:	SCALE: 3:8 SHEET INFO: 1 OF 1
FRACTIONS ± 1/16in ± 1.59mm TOLERANCES ON DECIMALS: 1 PLACE 2 PLACE 3 PLACE in ± .030 ± .010 ± .005 mm ± .76 ± .25 ± .13 ANGULAR DIMENSIONS ± 1 DEG REMOVE BURRS BREAK EDGES 0.01in 0.25mm MAX MAX SURFACE ROUGHNESS 12.5		ALL TECHNICAL DATA ON THIS DRAWING IS THE PROPERTY OF GS GLOBAL RESOURCES INC. AND SHALL NOT BE USED BY OTHERS FOR MANUFACTURE, PROCUREMENT, OR DISCLOSURE WITHOUT THE WRITTEN PERMISSION OF GS GLOBAL RESOURCES INC.	

TITLE BLOCK REVISION DATE: 10-9-2018