

Performance Ratings

Maximum Release Pressure3,000 PSI*
 Maximum Continuous Pressure3,000 PSI*
 Maximum Speed at Full Release Pressure ...3,900 RPM
 Maximum Operating Temperature.....170° F
 * 5,000 PSI Available

Volume of Oil to Release Brake0.5 cubic inches
 Approximate Weight15 lbs / 7 kg
 Shaft Splines 30° involute,
 flat root side fit per ANSI
 B92.1a-1976

Consult your Eskridge representative to determine ratings for your specific application or configuration.

internal - class 7, external - class 5

General Dimensions for 93-120 Brake

Other options may be available. See ordering information on last page or contact your Eskridge representative for more details.

Values are shown as "inches (millimeters)."

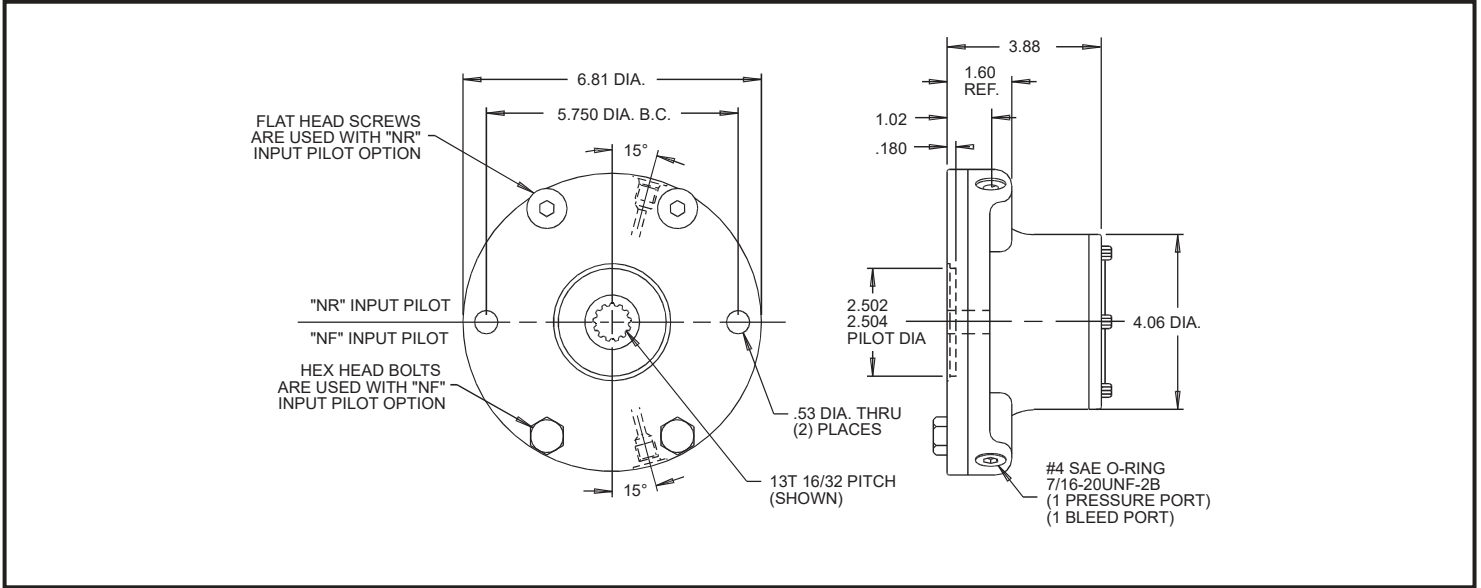



93-120 Multiple Disc Brake

Typical Applications: Industrial, Marine or Mobile Equipment

(913) 782-1238 (Tel)
 (913) 782-4206 (Fax)
Sales@EskridgeInc.com
www.EskridgeInc.com
 FORM: PS93120
 Page 2 of 2

Ordering Information

Example Part Number: 931NF2G046-B

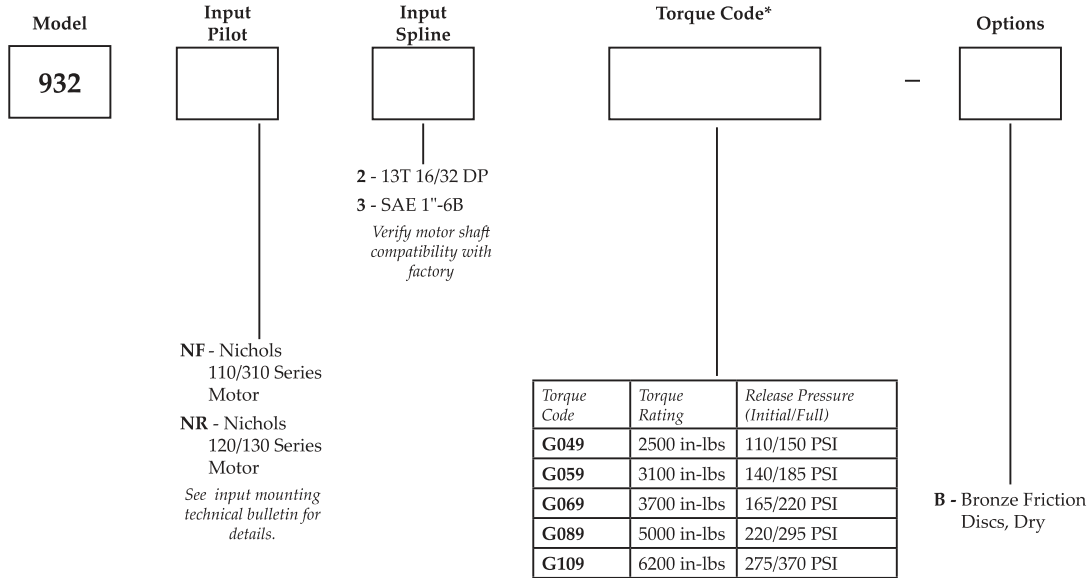

Values shown are standard units; other torques and release pressures are available. Consult Eskridge for additional information.

Torque - Torque ratings are based on standard friction material in ATF-F fluid media or dry bronze at (0) PSI back pressure. Break away torque may vary +/- 10% from specified ratings. The "W" wet option applies to bronze friction discs only and is furnished with mineral based hydraulic oil. Torque rating for wet bronze brakes will vary depending upon the type of oil used. Consult Eskridge for any wet or flow-thru brake applications. Use only mineral based hydraulic oil for release of brake. For flow-thru option "F", use only fluids that are compatible with internal seals.*