

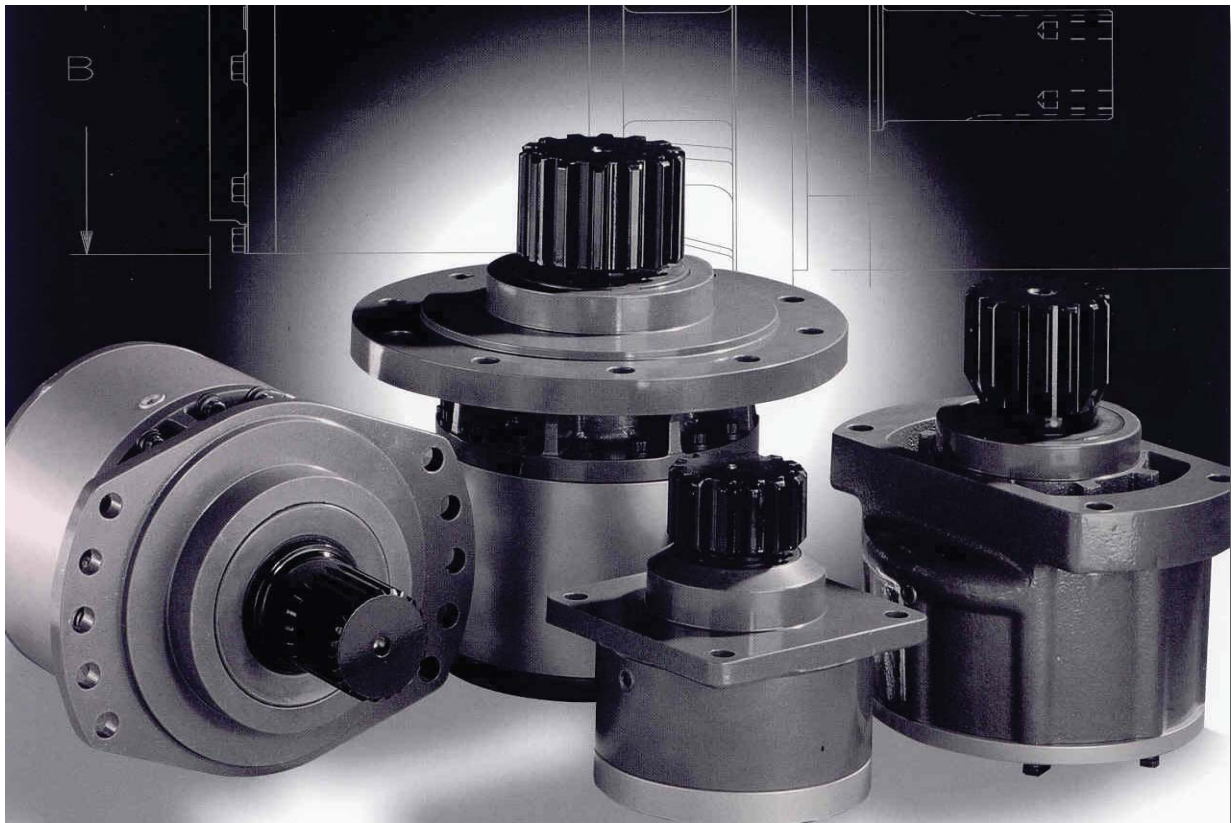

## MODEL 1000 DOUBLE PLANETARY SPINDLE DRIVE SERVICE MANUAL



**WARNING:** While working on this equipment, use safe lifting procedures, wear adequate clothing and wear hearing, eye and respiratory protection.

THIS SERVICE MANUAL IS EFFECTIVE:  
S/N:25000 TO CURRENT  
DATE:02/01/1996 TO CURRENT  
VERSION: SM1000LS2-AD

**NOTE:** Individual customer specifications (mounting case, output shaft, brake assembly, etc.) may vary from exploded drawing and standard part numbers shown. If applicable, refer to customer drawing for details.

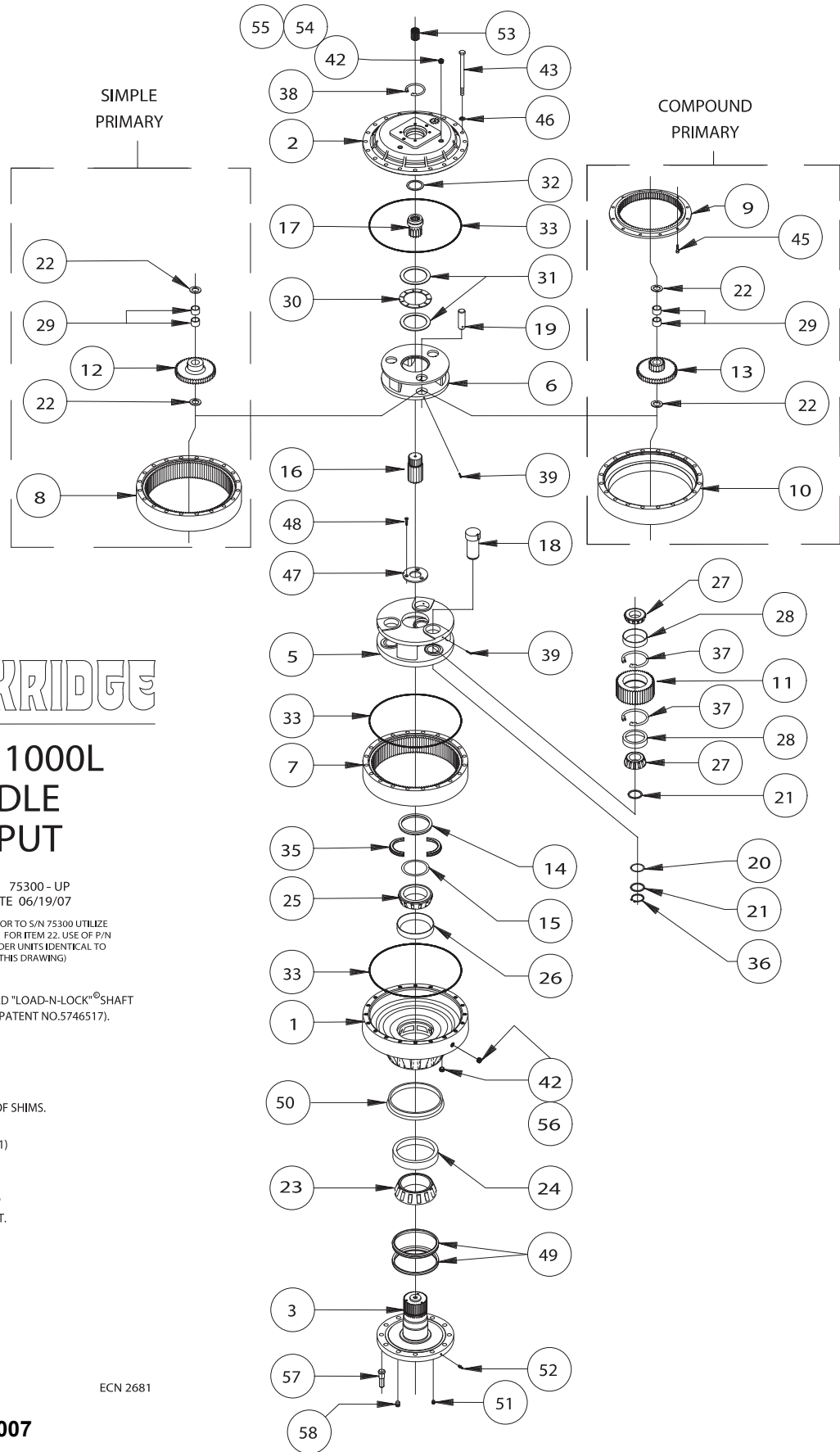

# MODEL 1000L SPINDLE OUTPUT

EFFECTIVE S/N 75300 - UP  
EFFECTIVE DATE 06/19/07

\*UNITS MANUFACTURED PRIOR TO S/N 75300 UTILIZE (OBSOLETE) P/N 60-004-1301 FOR ITEM 22. USE OF P/N 60-004-1881 WILL MAKE OLDER UNITS IDENTICAL TO CURRENT UNIT (SHOWN ON THIS DRAWING)

EQUIPPED WITH PATENTED "LOAD-N-LOCK"® SHAFT RETENTION SYSTEM (U.S. PATENT NO.5746517).

**NOTES:**

-J- BEARING PRELOAD  
DETERMINES QUANTITY OF SHIMS.

SEAL KIT (P/N 60-016-2101)

INCLUDES:

- 3 EA. ITEM (33) O-RINGS,
- 1 EA. ITEM (49) SEAL, AND
- 1 EA. ITEM (50) SEAL BOOT.

**X1000LS2-AD,**

**Page 1 of 2**

**Effective date 07/01/2007**

**Effective serial # 74362**

ECN 2681

# MODEL 1000L SPINDLE DRIVE

RATIOS →

SIMPLE PRIMARY		COMPOUND PRIMARY	
26.48:1	41.41:1	75.60:1	96.00:1

ITEM	QTY.	DESCRIPTION	SIMPLE PRIMARY		COMPOUND PRIMARY	
			PART NUMBER	PART NUMBER	PART NUMBER	PART NUMBER
1	1	CODE F - FLANGELESS	60-004-3034	60-004-3034	60-004-3034	60-004-3034
		CODE F - FLANGELESS W/ZERK GREASE FITTING	60-004-3034Z	60-004-3034Z	60-004-3034Z	60-004-3034Z
		CODE A - FLANGED	60-004-3044	60-004-3044	60-004-3044	60-004-3044
		CODE A - FLANGED W/ZERK GREASE FITTING	60-004-3044Z	60-004-3044Z	60-004-3044Z	60-004-3044Z
		600C - CUSTOM MTG - PER CUSTOMER SPECS.				
2	1	COVER - SAE 'C' (2 AND 4 BOLT)	60-004-1064	60-004-1064	60-004-1064	60-004-1064
		COVER - SAE 'D' (4 BOLT)	60-004-1074	60-004-1074	60-004-1074	60-004-1074
		COVER - SAE 'E' (4 BOLT)	60-004-1564	60-004-1564	60-004-1564	60-004-1564
3	1	CODE S1 - 17" DIA.; 12X 1 1/8 - 12 UNF-2B	60-004-4052L	60-004-4052L	60-004-4052L	60-004-4052L
		CODE S2 - 17" DIA.; 12X 1.225 DIA. THRU HOLES	60-004-4122L	60-004-4122L	60-004-4122L	60-004-4122L
		CODE C1 - SPINDLE - CUSTOM				
5	1	CARRIER - SECONDARY	60-004-1044	60-004-1044	60-004-1044	60-004-1044
6	1	CARRIER - PRIMARY	60-004-1014	60-004-1024	60-004-1024	60-004-1024
7	1	RING GEAR - SECONDARY	60-004-1243	60-004-1243	60-004-1243	60-004-1243
8	-	RING GEAR - SIMPLE PRIMARY	60-004-1193	60-004-1193	-	-
9	1	RING GEAR - COMPOUND PRIMARY	-	-	60-004-1213	60-004-1213
10	1	RING SPACER - PRIMARY	-	-	60-004-1253	60-004-1253
11	3	PLANET GEAR - SECONDARY	60-004-1232	60-004-1232	60-004-1232	60-004-1232
12	-	PLANET GEAR - PRIMARY	60-004-1132	60-004-1152	-	-
13	3	CLUSTER GEAR	-	-	60-004-1162	60-004-1182
14	1	LOCK RING - SHAFT BEARING	60-004-1472	60-004-1472	60-004-1472	60-004-1472
15	-J-	SHIM(S) - SHAFT	60-004-1311	60-004-1311	60-004-1311	60-004-1311
16	1	SUN GEAR	60-004-1222	60-004-1222	60-004-1222	60-004-1222
17	1	CODE 9 - (13T; 8/16 SPLINE)	60-004-1122	60-004-1142	60-004-1142	60-004-1172
		CODE 8 - (16T; 8/16 SPLINE)	60-004-1402	60-004-1492	60-004-1492	60-004-1452
18	3	PLANET SHAFT-SECONDARY	60-004-1262	60-004-1262	60-004-1262	60-004-1262
19	3	PLANET SHAFT-PRIMARY	60-004-1272	60-004-1272	60-004-1272	60-004-1272
20	-J-	SHIM(S) - SECONDARY PLANET	60-004-1321	60-004-1321	60-004-1321	60-004-1321
21	6	WASHER - SECONDARY PLANET	60-004-1291	60-004-1291	60-004-1291	60-004-1291
22	6	WASHER - PRIMARY PLANET	60-004-1881	60-004-1881	60-004-1881	60-004-1881
23	1	BEARING CONE - SHAFT OUTER	01-102-0190	01-102-0190	01-102-0190	01-102-0190
24	1	BEARING CUP - SHAFT OUTER	01-103-0190	01-103-0190	01-103-0190	01-103-0190
25	1	BEARING CONE - SHAFT INNER	01-102-0230	01-102-0230	01-102-0230	01-102-0230
26	1	BEARING CUP - SHAFT INNER	01-103-0230	01-103-0230	01-103-0230	01-103-0230
27	6	CONE - SEC.PLANET	01-102-0210	01-102-0210	01-102-0210	01-102-0210
28	6	CUP - SEC.PLANET	01-103-0210	01-103-0210	01-103-0210	01-103-0210
29	6	BRG-PRIMARY PLANET	01-105-0510	01-105-0510	01-105-0510	01-105-0510
30	1	BRG-PRI. CARR. THRUST	01-112-0340	01-112-0340	01-112-0340	01-112-0340
31	2	RACE-PRI. CARR. THRUST	01-112-0350	01-112-0350	01-112-0350	01-112-0350
32	1	RACE-INPUT THRUST	01-112-0060	01-112-0060	01-112-0060	01-112-0060
33	3	O-RING - RING GEAR	01-402-0660	01-402-0660	01-402-0660	01-402-0660
35	1	SPLIT RING	60-004-1482	60-004-1482	60-004-1482	60-004-1482
36	3	RETAINING RING-SEC. PIN	01-160-0490	01-160-0490	01-160-0490	01-160-0490
37	6	RETAINING RING-SEC. PLNT.	01-160-0500	01-160-0500	01-160-0500	01-160-0500
38	1	RETAINING RING - INPUT	01-160-0510	01-160-0510	01-160-0510	01-160-0510
39	6	ROLL PIN - PRI. 1/4 X 1 3/8	01-153-0150	01-153-0150	01-153-0150	01-153-0150
42	6	PIPE PLUG 3/4 NPT MAGNETIC	01-207-0100	01-207-0100	01-207-0100	01-207-0100
43	20	H.H.C.S 3/4-10 X 10.5 GRD 8	01-150-1580	01-150-1580	01-150-1580	01-150-1580
45	12	S.H.C.S 1/2-13 X 1.5 GRD 8	-	-	01-150-0570	01-150-0570
46	20	HARDWASHER - 3/4	01-166-0350	01-166-0350	01-166-0350	01-166-0350
47	1	RING - SEC CARRIER RETAINER	60-004-1352	60-004-1352	60-004-1352	60-004-1352
48	3	FLAT HD. SOC. C.S. 3/8-24 X 1 GR8	01-150-1590	01-150-1590	01-150-1590	01-150-1590
49	1	SEAL - METAL FACE	01-406-0010	01-406-0010	01-406-0010	01-406-0010
50	1	SEAL - RUBBER FACE	01-406-0020	01-406-0020	01-406-0020	01-406-0020
51	1	PIPE PLUG (1/8 NPT-HOLLOW HEX)	01-207-0030	01-207-0030	01-207-0030	01-207-0030
52	1	GREASE FITTING-STRAIGHT, 1/8 NPT	01-215-0010	01-215-0010	01-215-0010	01-215-0010
53	1	CODE 4; 14T, 12/24 D.P. (OPTIONAL)	98-005-1141	98-005-1141	98-004-1141	98-004-1141
		CODE 7; 17T, 12/24 D.P. (OPTIONAL)	60-004-1523	60-004-1523	60-004-1523	60-004-1523
54	(1)	CODE V - AIR VENT; 1/8 NPT (OPTIONAL)	01-216-0030	01-216-0030	01-216-0030	01-216-0030
55	(1)	ADAPTER; 3/4" NPT-M, 1/8" NPT - F (OPTIONAL)	01-201-0530	01-201-0530	01-201-0530	01-201-0530
56	(-)	CODE Z - GREASE FIT-STR, 1/4 NPT (OPTIONAL)	01-215-0040	01-215-0040	01-215-0040	01-215-0040
57	(12)	CODE S - SPINDLE STUDS (OPTIONAL)	01-164-0050	01-164-0050	01-164-0050	01-164-0050
58	1	PIPE PLUG (1/4 NPT)	01-207-0020	01-207-0020	01-207-0020	01-207-0020

X1000LS2-AD

Page 2 of 2

Effective date 07/01/2007

Effective serial # 74362

# LUBRICATION & MAINTENANCE





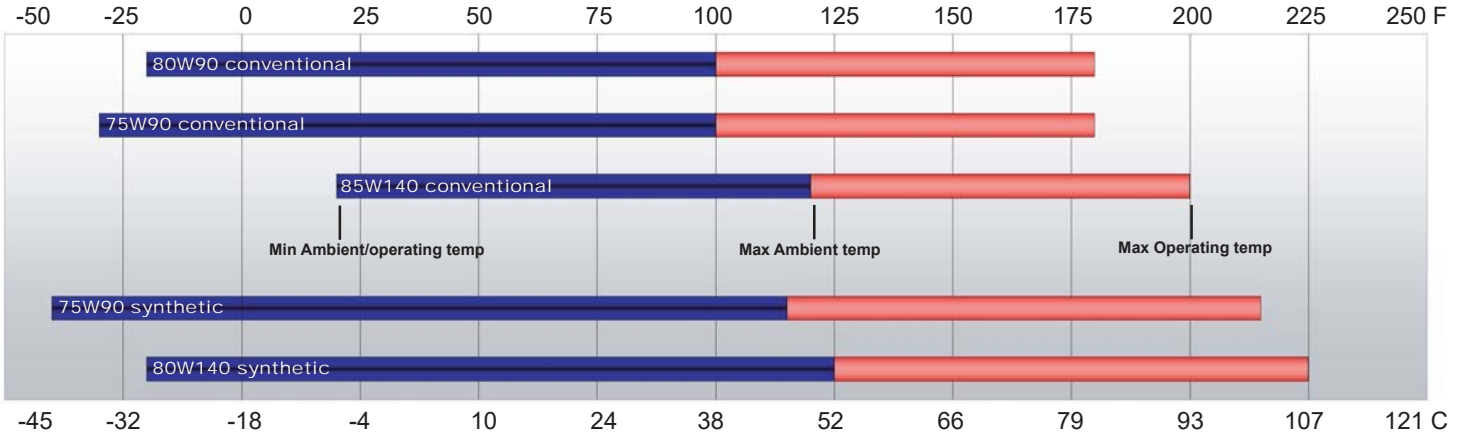

Using the chart below, determine an appropriate lubricant viscosity. Use only EP (extreme pressure) or API GL-5 designated lubricants. Change the lubricant after the first 50 hours of operation and at 500 hour intervals thereafter. The gear drive should be partially disassembled to inspect gears and bearings at 1000 hour intervals.

## Recommended ambient and operating temperatures for conventional and synthetic gear lubricants



**Note:** Ambient temperature is the air temperature measured in the immediate vicinity of the gearbox. A Gearbox exposed to the direct rays of the sun or other radiant heat sources will operate at higher temperatures and therefore must be given special consideration. The max operating temp must not be exceeded under any circumstances, regardless of ambient temperature.

## ESKRIDGE MODEL 1000 OIL CAPACITIES

Operating Position		Oil Capacity			Oil Level	
		Single stage	Double stage	Triple stage		
	Horizontal Shaft	-	17 qts / 16 Liters	19 qts / 18 Liters	To horizontal centerline of gear drive	
	Vertical Shaft (Pinion Up)	-	26 qts / 24 Liters	28 qts / 26 Liters	To side port on gear drive base	
	Vertical Shaft (Pinion Down)		29 qts / 27 Liters	32 qts / 30 Liters	To midway on upper/primary gear set	

## ESKRIDGE PART NUMBER INTERPRETATION

**Note:** All standard Eskridge Geardrives are issued a descriptive part number which includes information regarding the Model, means of shaft retention, base style, shaft style, input mounting, input shaft size, overall ratio and various available options. For a detailed breakdown of this information, please refer to Eskridge product specification sheets found at: <http://www.eskridgeinc.com/geardrives/gearprodspecs.html>

# Unit Teardown

- 1) Scribe a diagonal line across the outside of the unit from the cover (2) to the base (1) before disassembly to aid in the proper positioning of pieces during reassembly.
- 2) Remove drain plugs (42) and drain oil from unit. The oil will drain out more quickly and completely if warm.
- 3) Remove the 20 3/4-10 capscrews (43) and lockwashers (46) retaining the cover (2).
- 4) Remove the cover (2), thrust washer(s)/bearing(s) (30,31,32), and input gear (17). Inspect o-ring (33); discard if damaged or deformed.
- 5) Lift the planet carrier assembly out of the unit .
- 6) Remove ring gear(s)/spacer (8/10pri, 7sec) and subsequent carrier assemblies. Inspect gear to gear and gear to base O-ring(s) (33); as before, discard if damaged or deformed.
- 7) The unit is now disassembled into groups of parts. The area(s) requiring service should be identified by thorough inspection of the individual components after they have been cleaned and dried.

## Carrier Assembly Teardown

**Rotate planet gears (12/13 pri;11 sec) to check for abnormal noise or roughness in bearings. If further inspection or re- placement is required, proceed as follows.**

- 1) *Primary:* Drive roll pins (39) completely into the planet shafts (19). *Secondary:* Remove planet shaft retaining rings (36), spacers (21) and preload shims (20)
- 2) Slide planet shafts (19 pri/18 sec) out of carrier.
- 3) Remove planet gears (12/13 pri; 11 sec), washers (22 pri/21 sec) and bearings (29 pri;27/28 sec) from carrier (6).
- 4) Inspect the planet gear (12/13 pri; 11 sec), bearing bore and planet shaft (19 pri/18 sec) and bearings (29 pri; 27/28 sec). Check for spalling, bruising or other damage and replace components as necessary.
- 5) *Primary only:* Remove roll pins (39) from planet shafts (19) using a 1/4 inch pin punch.

## Carrier Reassembly

- 1) *Primary:* Planet shafts (19) should be installed with chamfered end of 1/4 inch roll pin hole towards outside diameter of carrier (6); this will ease alignment of holes while inserting roll pins (39). *Secondary:* Planet shafts must be installed aligning the slot in the large end of the shaft with the roll pin protruding into the shaft bore.
- 2) *Primary:* Drive roll pin (39) into the carrier hole and into planet shaft to retain parts. *Secondary:* Install the first planet washer (21) to the small end of the planet shaft, the appropriate number of preload shims (20) and then the second planet washer (21) and retaining ring (36) Repeat for remaining planet gears.

## Base Subassembly Teardown

- 1) Remove the output shaft lock ring (14) using a heel bar or puller; if using a heel bar, be sure not to pry against the cage of the inner spindle bearing (25). Remove the split ring segments (35) and shims (15).

**Caution: Since the shaft is no longer positively retained, care should be taken to avoid injury. Care should also be taken not to damage it while pressing through base.**

- 2) Place base (1) exterior side down, on a plate or table. Press output shaft out bottom of base by applying a load to internal end of spindle (3) until it passes through inner spindle bearing cone (25).
- 3) A gear puller may be used to remove the outer bearing cone (23) from the spindle (3). If reusing old bearing cone, do not pull on or damage roller cage.

**Note: Press bearing cone onto output spindle by pressing on inner race only. DO NOT press on roller cage, as it may damage the bearing assembly.**

- 4) Inspect inner and outer bearing cups (26 & 24). If cups are damaged they must be replaced, drive them out using a brass drift and utilizing the bearing knock-out notches in the base (1)

## Base Reassembly

- 1) Clean all foreign material from magnetic oil plugs located in base (1).
- 2) Place base exterior side up on work table.
- 3) Apply a layer of lithium or general purpose bearing grease to the roller contact surface of outer bearing cup (24).
- 4) Press outer bearing cone (23) onto the spindle (3) until it seats against the shoulder.
- 5) Wipe the face of each half of the metal face seal (49) using a lint-free wipe. No particles of any kind are permissible on the sealing surfaces. (Even a hair is sufficient to hold the seal surfaces apart and cause a leak.) Apply a thin film of oil on the entire seal face of one or both seals using a clean finger or lint-free applicator. Oil must not contact any surfaces other than the sealing faces. (See Pages 6-8 for seal inspection and service procedures.)
- 6) Place the spindle (3) with the outer bearing cone into the base.
- 7) Flip shaft/base assembly, and apply lithium or general purpose bearing grease to roller contact surface of the inner cup (26), then press inner bearing cone (25) onto shaft until it seats against inner bearing cup.
- 8) Proper spindle bearing preload will result in a rolling torque which varies between 200 to 300 in-lb. The bearing preload should be tailored to your application; a low-speed application may require a high pre-load, while high-speed applications usually benefit from low pre-load. Adding shims (15) will increase the pre-load on the bearing set. Determine your pre-load requirement and install shims to obtain this pre-load.
- 9) Install the Load-N-Lock™ halves (35) over the shims and into the corresponding spindle groove. Then, install the lock ring (14) over the Load-n-Lock halves (35B).

**All subassembly service or repairs should be complete at this time. Continue to Unit Assembly to com-**



plete buildup of unit.

## Unit Reassembly

- 1) Install the secondary carrier assembly onto the output spindle; aligning the splines of the carrier (5) with the output spindle (3) splines and centering the three threaded holes in the output spindle between the planet gears. Once aligned slide the carrier onto the spindle.
- 2) Install carrier retaining plate (47) & secure using provided 3/8-24 Flathead capscrews (48). If using thread locking compound to assist in screw retention, apply only a small amount to internal threads. Use of excess thread lock may cause screws to be irremovable once compound has cured.
- 3) Lubricate o-ring (33) and install on the ring gear (7) pilot.

**Caution: Hold ring gear by outside diameter or use lifting device to prevent injury.**

- 4) Align the gear teeth of secondary ring gear (7) with the gear teeth of the planet gears (11) and place ring gear on base aligning mounting holes of ring gear with holes in base. Use the scribed line made during disassembly for reference. With carrier in place, install secondary sun gear.

*Simple Planetary Primary, for compound primary skip to step 5C*

- 5S) Install primary ring gear (with lubricated o-ring in place), align mounting holes of ring gear with holes in base using the scribed line made during disassembly for reference. Install the primary carrier assembly aligning gear teeth of ring gear with those of the planet gears and place on base. Install the input gear (17).

*Compound primary (76:1 ratio and up):*

- 5C) a) The planet gears will now need to be timed. Refer to the diagram appropriate for your unit's gear ratio (above, right). The planet gears each have a timing mark, usually a round punch mark stamped into the surface which is shown as a circle on the diagram.  
b) As seen from above, start with the top planet gear with its timing mark pointing straight down. Next, rotate the lower left planet gear counterclockwise as indicated in the timing diagram. Then rotate the lower right planet gear clockwise as indicated.  
c) Set the input gear (17) and the input thrust race (32) into the center of the primary planet carrier assembly.  
d) If compound primary ring gear (9) was not removed during disassembly, then skip to step 7. Otherwise, bolt to the inside of the cover (2) with twelve bolts (45). Use a removable thread locking compound on the threads of the bolts (45). Tighten to 110 ft.-lbs. dry or 80 ft.-lbs. lubricated.  
e) Install primary ring spacer (10) w/ O-ring (33) in place.
- 6) Install the input to cover thrust washer (32) and carrier to cover thrust washers (31, 2ea; 30, 1ea) Refer to exploded view for details.
- 7) Noting the scribed line made during disassembly, (with lubricated o-ring in place) align and install the cover (2).

- 8) Install and torque the 20 3/4-10 hex-head cap-screws (43) with lockwashers (46). The torque for the cap-screws: 380 ft-lb dry, 280 ft-lb if the fasteners are lubricated.
- 9) Using a splined shaft to drive the input gear (17) ensure that the unit spins freely.
- 10) Fill the unit to the proper level, as specified, with recommended gear oil (refer to chart, page 3) after unit is sealed with brake and/or motor.

**The gearbox is now ready to use. The gear drive is now ready to use.**

### PRIMARY CARRIER TIMING DIAGRAMS

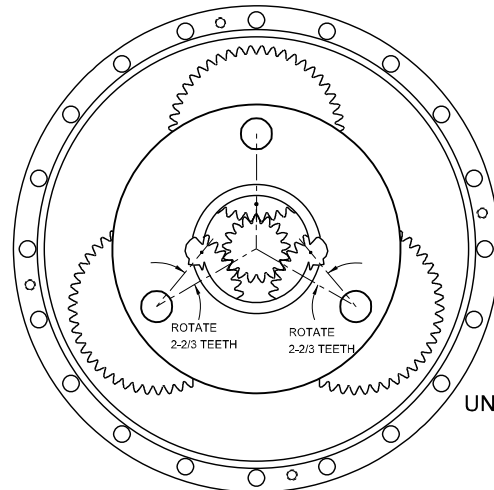

UNIT RATIO  
76:1

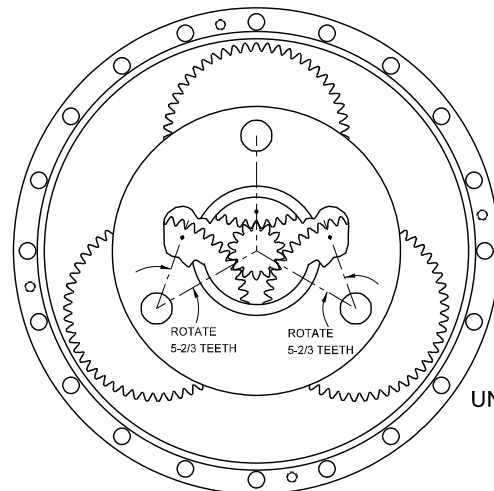

UNIT RATIO  
96:1

# Seal Assembly for Duo-Cone Seals

Installation Instructions courtesy Caterpillar, Inc.

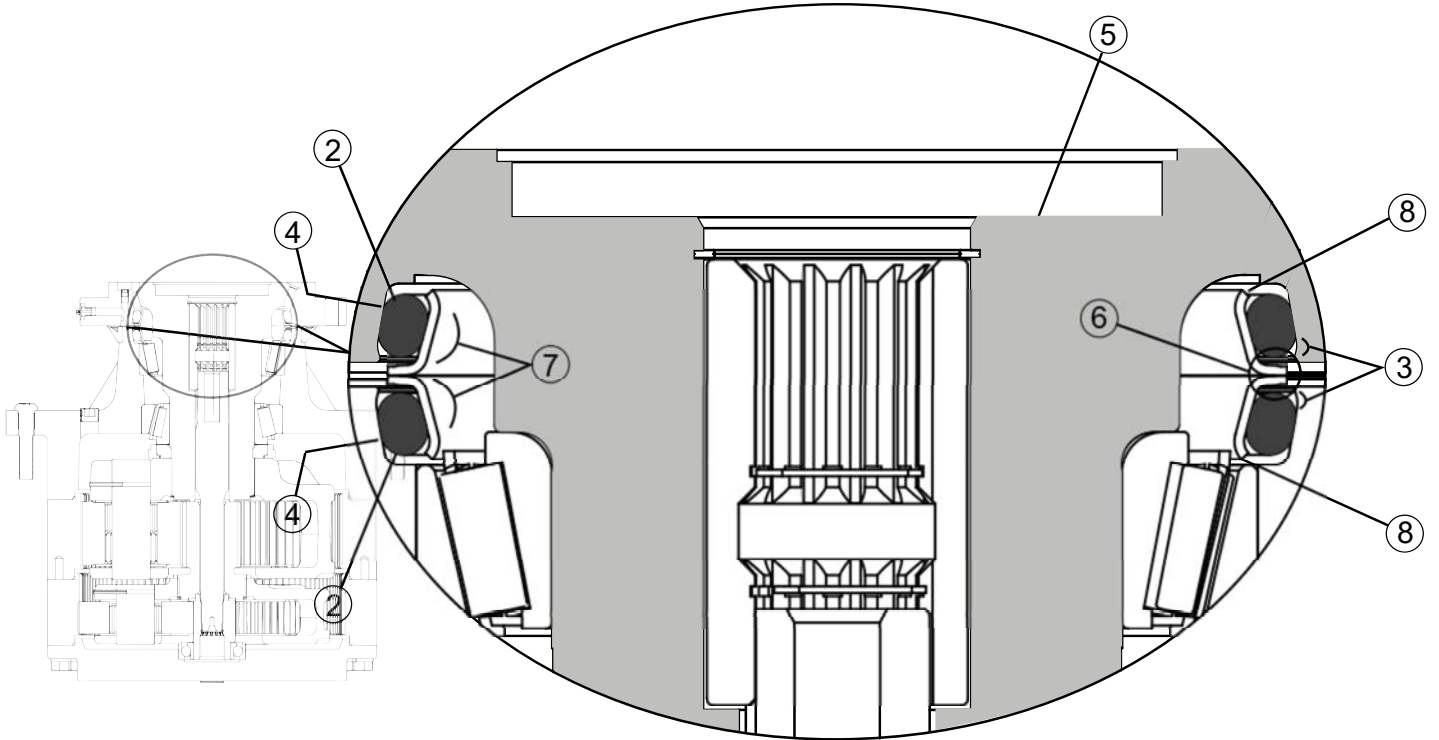

Cross Section View of Installed Seal

## Seal Assembly Contents:

(2) Metal Seal Rings

(2) Rubber Toric Rings

## Terminology:

- |                                    |                                  |
|------------------------------------|----------------------------------|
| 1 - Seal Ring                      | 6 - Seal Ring Face               |
| 2 - Rubber Toric                   | 7 - Seal Ring Ramp               |
| 3 - Housing Retainer Lip           | 8 - Seal Ring Retaining Lip      |
| 4 - Housing Ramp                   | 9 - Installation Tool (Optional) |
| 5 - Seal Ring Housing (Base/Shaft) |                                  |

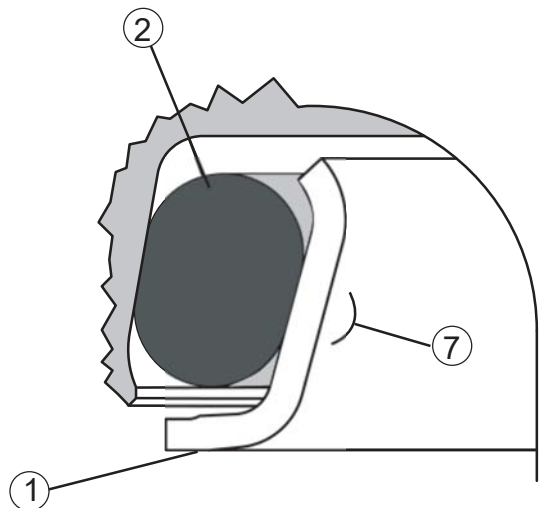

## Inspection of Worn Seals

Seals wear in an axial, rather than radial, direction (as depicted in Figure Y). The total thickness of the flange is usable wear material on the formed seal rings and good seal performance can generally be expected until the flange is completely worn away. Remaining service life can be estimated by measuring the ring flange thickness, and using the chart below. Minimum flange thickness required for reusability is 0.05" (1.27 mm).

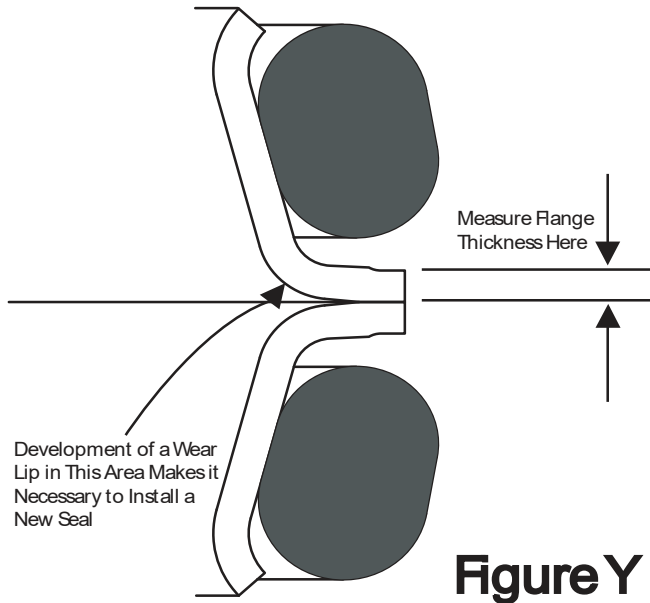

The measured parameter used to check the remaining seal life is flange thickness, at the outer edge (once any wear lip is removed). The measurement must be made carefully because the shoulder is only 0.06" (1.52 mm) from the edge of the flange.

Estimates of expected seal life are difficult, because there are many differences in machine applications, job conditions, maintenance and other factors that affect seal service life.

Formed Seal Wear Chart	
Flange Thickness in (mm)	Seal Wear Percent Worn
0.075 (1.91)	0
0.062 (1.59)	25
0.050 (1.27)	50
0.038 (0.95)	75
0.025 (0.64)	100
0.012 (0.32)	125
0.000 (0.00)	150

## Mishandling Of Seals

Mishandling of seals during assembly can cause immediate leaks or premature failure. Failure can occur due to cutting or tearing of the elastomeric load ring, breakage of the sealing ring, contamination of the sealing face with dirt or lint, etc. When assembling metal face seals, please carefully observe assembly instructions.

## Housing Preparation

The housing components (3, 4) that contact the rubber toric rings must be free from foreign material (oil, grease, dirt, metal chips dust or lint particles, etc.) before installing the seal. This should be done with a lint-free wipe and a non-petroleum based solvent.

- 1) Remove any foreign material from the rubber torics (2), ramps (7) and lips (8) of both seal rings. This should also be done with a lint-free wipe and non-petroleum based solvent.
- 2) Dry with a clean wipe.
- 3) Place the rubber toric (2) on the metal seal ring (6) at the bottom of the seal ring ramp (7) and against the retaining lip (8) (see illustration on previous page). Make sure the rubber toric is straight on the seal ring and not twisted. Be careful not to nick or cut the torics during this assembly, as this can cause leaks.
- 4) Put the installation tool (9) onto the metal seal ring (6) and rubber toric (2). Lightly dampen the lower half of the rubber toric with the appropriate assembly lubricant. Techniques to dampen the toric include wiping with a lint-free towel, lubricating using a clean foam brush, or dipping into a container lined with towels saturated in the assembly lubricant (as shown).

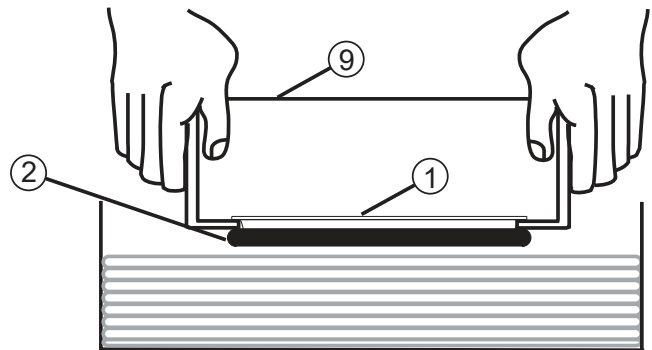

## Approved Assembly Lubricants\*

Isopropyl Alcohol

Houghto-Grind 60 CT

Quaker® Solvo Clean 68-RAH

\*Do not use Stanosol or any other liquid that leaves an oil film or does not evaporate quickly.



## Installation Process

- 1) With the lower half of the rubber toric still wet, use the installation tool (9) to position the seal ring (1) and the rubber toric (2) squarely against the housing retainer lip (3) (as shown).
- 2) For smaller diameter seals, use sudden and even pressure to push the rubber toric under the retaining lip of the housing. For larger diameter seals, which will not press in with sudden and even pressure, it is acceptable to work the toric past the retaining lip by starting on one side and tapping the opposite side of the installation tool with a rubber mallet until it is engaged past the retaining lip of the housing.
- 3) Check the assembled height (A) (see below) in at least four places, 90° apart, using either a caliper, tool makers' ruler or any other calibrated measuring device. The difference in height around the ring must not be more than 0.04" (1 mm). If small adjustments are necessary, do not push or pull directly on the seal ring. Use the installation tool (9) to push down and your fingers to pull up uniformly on the rubber toric and seal ring.

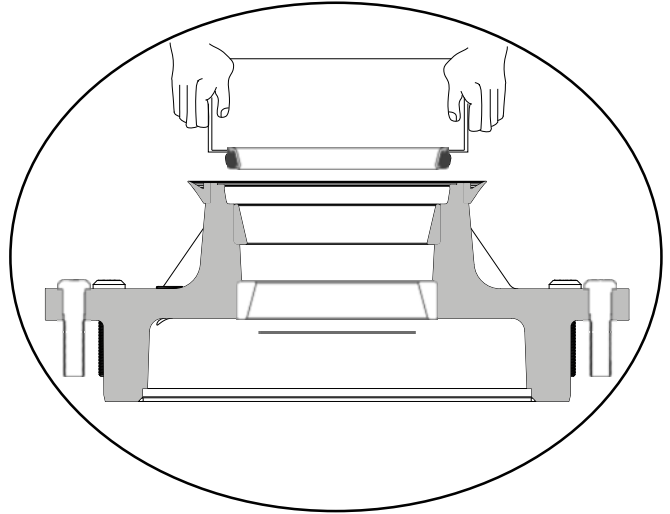

**NOTE: The rubber toric can twist if it is not completely wet during installation or if there are burrs or fins on the retaining lip of the housing. Twists, misalignments and bulges of the toric will result in seal failure. If correct installation is not apparent, remove seal from the housing and repeat the process.**

**The rubber toric must never slip on the ramps of either the seal ring or the housing. To prevent slippage, allow adequate evaporation time for the lubricant before proceeding with further assembly. Once correctly in place, the rubber toric must roll on the ramp only.**

- 4) Wipe each seal ring face (6) using a lint-free wipe. No particles of any kind are permissible on the sealing surfaces. (Even a hair is sufficient to hold the seal surfaces apart and cause a leak.)
- 5) Apply a thin film of oil on the entire seal face (6) of one or both seals using a clean finger or lint-free applicator. Oil must not contact surfaces other than the sealing faces.

**NOTE: Mishandling of seals during assembly can cause immediate leaks or premature failure. Failure can occur due to curing or tearing of the elastomeric load ring, breakage of the sealing ring, contamination of the sealing face with dirt or lint, etc. When assembling metal face seals, please carefully observe assembly instructions.**

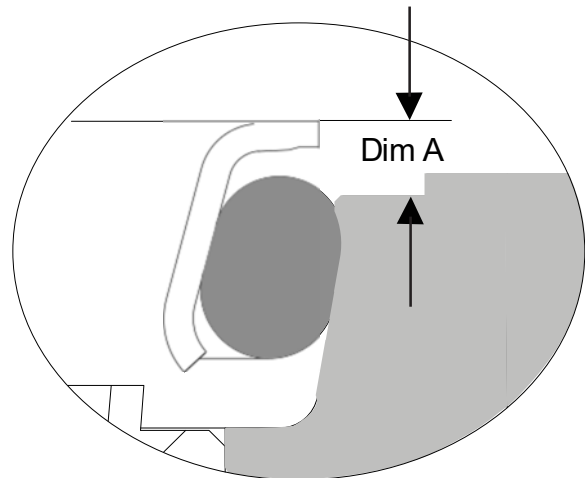

## Final Assembly

While completing the final assembly of the unit, make sure that both housings are in correct alignment and are concentric. Slowly bring the two housings together. High impact can scratch or break the seal components.

If the rubber toric slips at any location, it will twist, causing the seal rings to cock. Any wobbling motion of the seal is an indication of cocked seals and can cause dirt to enter by pumping mud past the torics.