

Fluid Cooling Mobile DF Series

Performance Notes

- Similar to DH with DC fan
- 3/4" tube size
- Low amp draw 12 or 24 V DC motors
- Heavy duty construction
- Long life hydraulic motors
- Rugged applications
- Steel manifolds
- Heat removal to 35,000 BTU/HR
- Oil flows to 110 GPM
- Mounting brackets included
- SAE, NPT or 37° flare oil connections
- Damage resistant steel fins

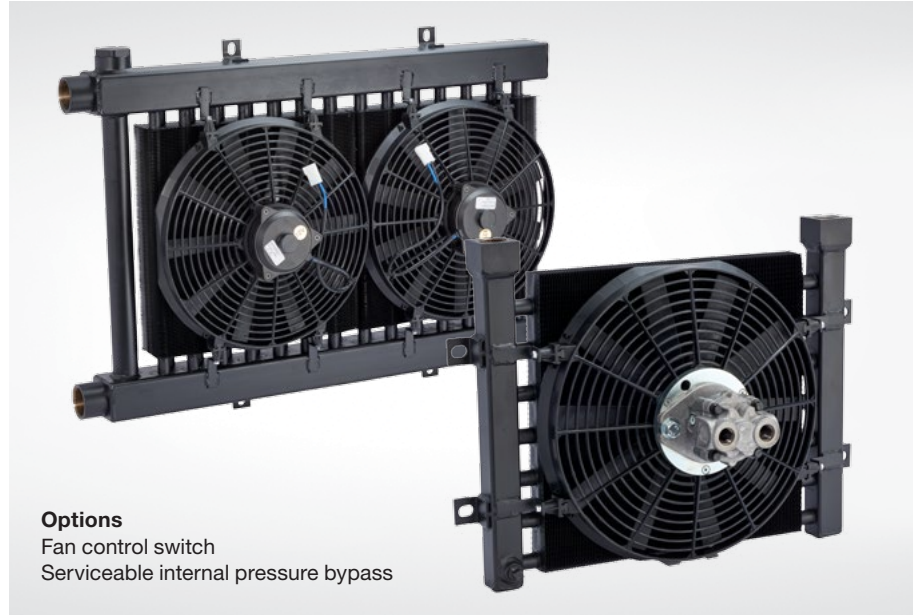

Options
Fan control switch
Serviceable internal pressure bypass

Ratings

Maximum Operating Pressure
300 PSI

Test Pressure
300 PSI

Maximum Operating Temperature
350°F

Hydraulic Motor Displacement
.22in³/Rev.

Maximum Hydraulic Motor Pressure
2000 PSI

Maximum Allowable Hydraulic Motor Back Pressure
1000 PSI

Materials

Tubes Copper

Fins Steel

Turbulators Steel

Manifolds Steel

Fan Assembly High Impact Plastic

Internal Pressure Bypass Option

DFR-11

3/4", external, all steel valve. Available in either 30 PSI or 60 PSI settings. May be removed for servicing.

DFR-12, DFR-22

1½", external, all steel valve. Available in either 30 PSI or 60 PSI settings. May be removed for servicing.

Number of Fans	DC Current Required		Hydraulic Motor Data		
	12 V	24 V	Oil Flow Required (GPM)	Minimum Operating Pressure (PSI)	Maximum Fan Speed (RPM)
1	12.5 amps	6.3 amps	2.1	300	2200
2	25 amps	12.6 amps	4.2	300	2200

How to Order

[]	-	[] []	-	[]	-	[]
Model Series DF DFR - Internal pressure bypass included		Model Size Selected		Connection Type* 1 - NPT 2 - SAE 3 - BSPP 7 - 37° Male Flare		Motor Specification NM - No Motor 4A - 12 Volt DC 4B - 24 Volt DC 9 - Hydraulic Motor
						Bypass Blank - No Bypass 30 - 30 PSI 60 - 60 PSI ADD FOR DFR MODELS ONLY

This is a partial flow pressure bypass only. It is not designed to be a full flow system bypass.

Dimensions - 12 & 24 Volt DC Motors

Models DF-11 and DF-12

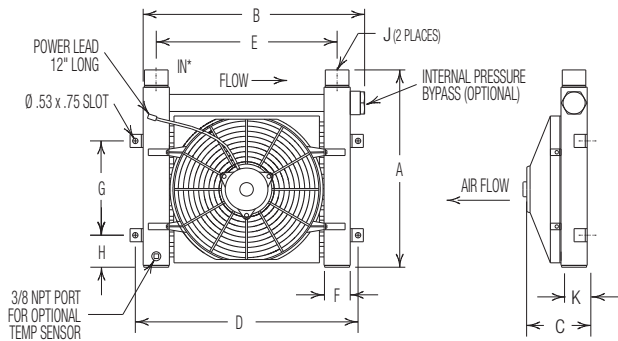

Model DF-22

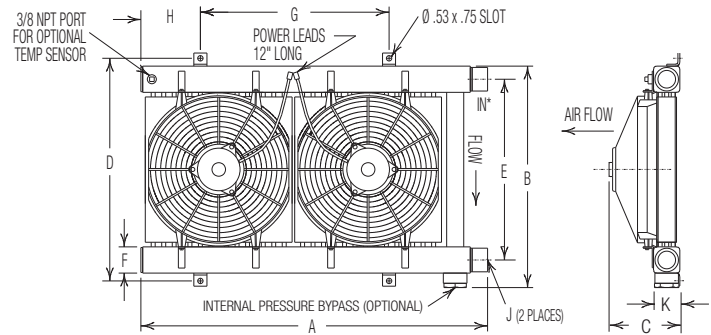

Units shown with optional internal pressure bypass

Model	A		B		C	D	E	F	G	H	J		K	Shipping Weight (LBS)
	DF	DFR	DF	DFR							NPT	SAE		
DF-11	16.12	18.00	19.25	20.91	5.51	20.75	17.75	1.50	7.50	3.69	1.00	#16	1.50	38
DF-12	17.00	18.25	21.25	22.91	7.01	22.75	18.75	2.50	7.50	3.69	1.00	#16	3.00	57
DF-22	31.47	33.73	21.25	22.62	7.01	22.75	18.75	2.50	14.25	7.69	1.50	#24	3.00	110

Note: All dimensions are in inches. We reserve the right to make reasonable design changes without notice.
*Inlet and Outlet connections can be reversed when the internal pressure bypass is not used.

Dimensions - Hydraulic Motors

Models DF-11 and DF-12

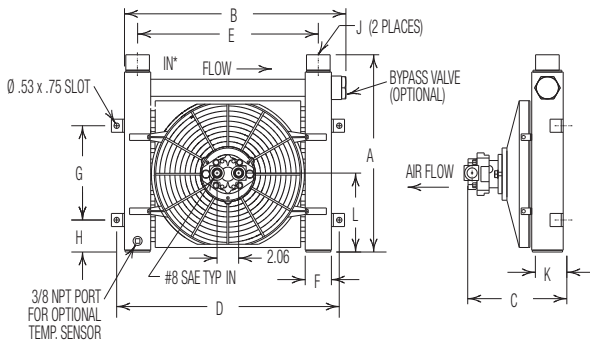

Model DF-22

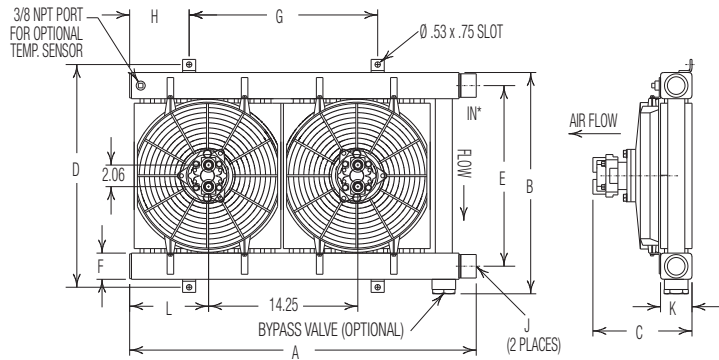

Units shown with optional internal pressure bypass

Model	A		B		C	D	E	F	G	H	J		K	L	Shipping Weight (LBS)
	DF	DFR	DF	DFR							NPT	SAE			
DF-11	16.12	18.00	19.25	20.91	7.47	20.75	17.75	1.50	7.50	3.69	1.00	#16	1.50	7.56	38
DF-12	17.00	18.25	21.25	22.91	9.46	22.75	18.75	2.50	7.50	3.69	1.00	#16	3.00	7.56	57
DF-22	31.47	33.73	21.25	22.62	9.46	22.75	18.75	2.50	14.25	7.69	1.50	#24	3.00	7.60	110

Note: All dimensions are in inches. We reserve the right to make reasonable design changes without notice.
*Inlet and Outlet connections can be reversed when the internal pressure bypass is not used.

Performance Curves

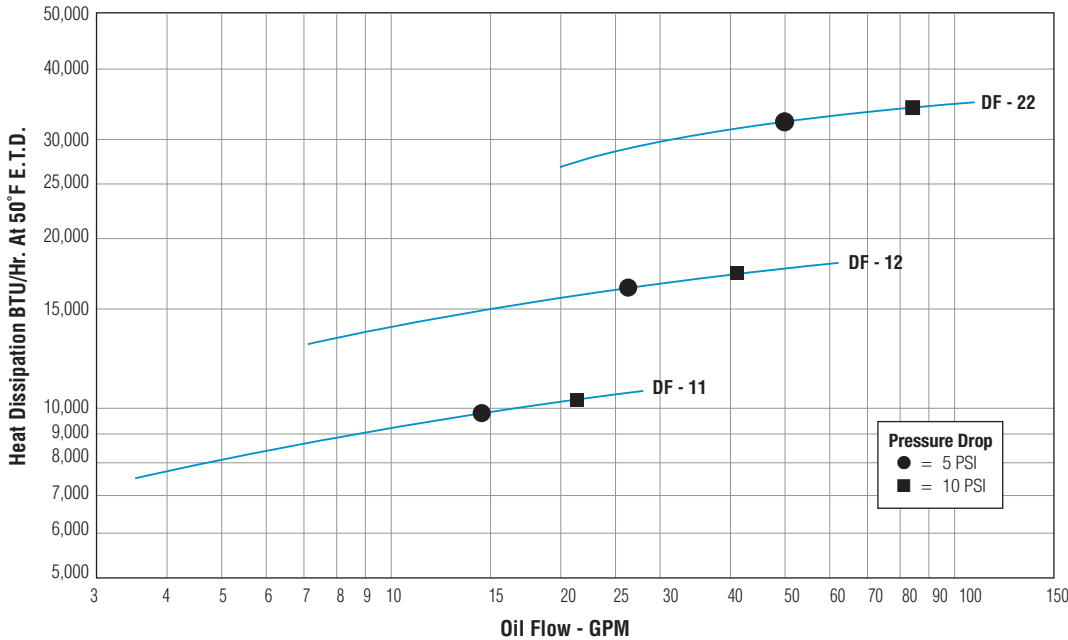

Oil Pressure Correction

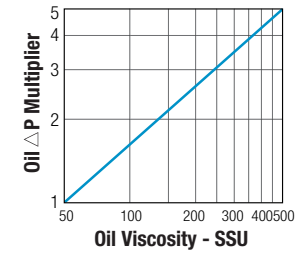

Selection Procedure

Performance Curves are based on 50 SSU oil entering the cooler 50°F higher than the ambient air temperature used for cooling. This is referred to as a 50°F ETD

STEP 1 Determine the Heat Load. Heat load may be expressed as either horsepower or BTU/HR To convert horsepower to BTU/HR:
 $BTU/HR = Horsepower \times 2545$

STEP 2 Determine Entering Temperature Difference. The entering oil temperature is generally the maximum desired oil temperature.
 Entering oil temperature – Ambient air temperature = ETD

STEP 3 Determine the Corrected Heat Dissipation to use the curves.
 $Corrected\ Heat\ Dissipation = BTU/HR\ heat\ load \times \frac{50^\circ F \times C_v}{ETD}$

STEP 4 Enter curves at oil flow through cooler and curve heat dissipation. Any curve above the intersecting point will work.

STEP 5 Determine Oil Pressure Drop from Curves:
 ● = 5 PSI ■ = 10 PSI Multiply pressure drop from curve by correction factor found in oil Δ P correction curve.

Oil Temperature

Typical operating temperature ranges are:

Hydraulic Motor Oil	120°F - 180°F
Hydrostatic Drive Oil	160°F - 180°F
Engine Lube Oil	180°F - 200°F
Automatic Transmission Fluid	200°F - 300°F

C_v Viscosity Correction

Average Oil Temp °F	OIL				
	SAE 5 110 SSU at 100°F 40 SSU at 210°F	SAE 10 150 SSU at 100°F 43 SSU at 210°F	SAE 20 275 SSU at 100°F 50 SSU at 210°F	SAE 30 500 SSU at 100°F 65 SSU at 210°F	SAE 40 750 SSU at 100°F 75 SSU at 210°F
100	1.14	1.22	1.35	1.58	1.77
150	1.01	1.05	1.11	1.21	1.31
200	.99	1.00	1.01	1.08	1.10
250	.95	.98	.99	1.00	1.00

Thermostatic Temperature Control Option (DC)

This controller was designed to mount on the cooler without requiring extensive wiring or plumbing. It provides accurate temperature control by cycling the cooling fan(s) to maintain desired oil temperature.

- 12 or 24 volt operation
- Adjustable temperature settings range from 100°F thru 210°F
- For use with one or two fan models — two fans need additional relay
- Temperature sensor provided
- Wiring provided for remote manual override
- Mounting hardware included

Part Number	Description
96171	Electronic Fan Control Kit
68790	Replacement Control Only
67699	Replacement Sensor Only



Side View

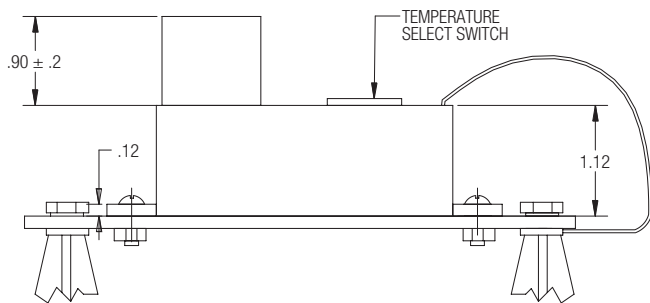

Connection Assembly

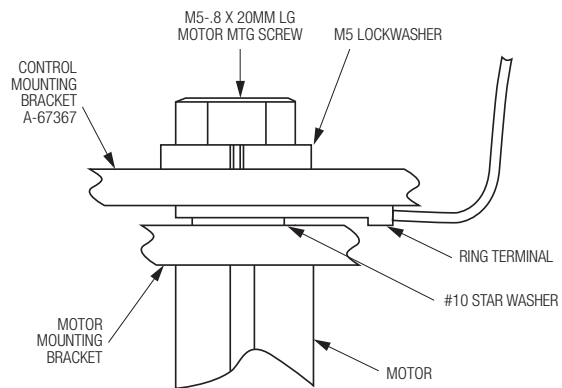

Top View

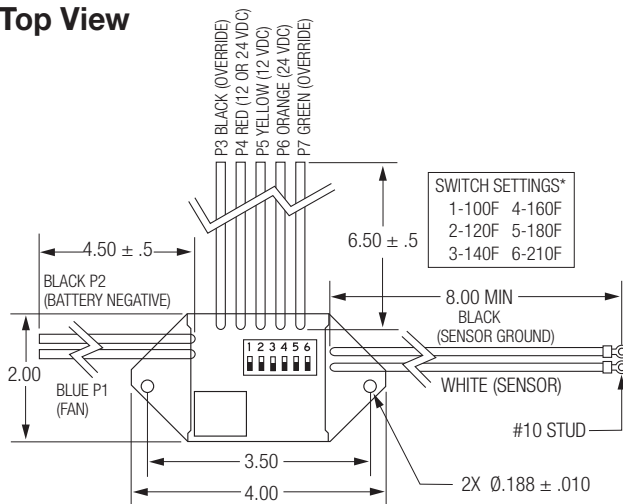

*Only one temperature setting can be activated at a time.

NOTE: This switch should be fused to prevent damage if ground is lost. A 30 amp fuse is required in the power supply.

Electrical Schematic

