

C Series Variable Displacement Axial Piston Pumps For Closed-Circuit Applications

HY28-2686-01/C/US Revised June 2017



Contents

General Information	1
Model Codes	2
Technical Data	6
Efficiency Information	8
C055	8
C081	9
C136	10
Controls	11
Manual Lever Control With Feedback – A	11
Hydraulic Proportional Control With Feedback – C	13
Hydraulic Proportional Control Without Feedback – D	15
Electric Non-Proportional – E	17
Electric Proportional Control With Feedback – F	19
Electric Proportional Control Without Feedback – G	22
Electric Proportional Control With Hydraulic Emergency Override – H.....	25
Automotive – J/K	28
Pressure Override Options	30
Pressure Override – P.....	30
Electric Cut-Off Valve – E	31
Electrical Cut-Off Valve and Pressure.....	32
Charge Filtration Options	33
Remote Charge Filtration – R	35
Dimensions – C55	37
Pump and Controls.....	37
Shaft	41
Through Drives	42
Dimensions – C081	44
Pump and Controls.....	44
Shaft	50
Pump and Accessories.....	51
Through Drives	54
Dimensions – C136	56
Pump and Controls.....	56
Shaft	60
Pump and Accessories.....	61
Through Drives	62
Installation Information	66
Offer Of Sale	69
Notes	70
Revisions	71

⚠ WARNING - USER RESPONSIBILITY

FAILURE OR IMPROPER SELECTION OR IMPROPER USE OF THE PRODUCTS DESCRIBED HEREIN OR RELATED ITEMS CAN CAUSE DEATH, PERSONAL INJURY AND PROPERTY DAMAGE.

This document and other information from Parker-Hannifin Corporation, its subsidiaries and authorized distributors provide product or system options for further investigation by users having technical expertise. The user, through its own analysis and testing, is solely responsible for making the final selection of the system and components and assuring that all performance, endurance, maintenance, safety and warning requirements of the application are met. The user must analyze all aspects of the application, follow applicable industry standards, and follow the information concerning the product in the current product catalog and in any other materials provided from Parker or its subsidiaries or authorized distributors. To the extent that Parker or its subsidiaries or authorized distributors provide component or system options based upon data or specifications provided by the user, the user is responsible for determining that such data and specifications are suitable and sufficient for all applications and reasonably foreseeable uses of the components or systems.

Offer of Sale

The items described in this document are hereby offered for sale by Parker-Hannifin Corporation, its subsidiaries or its authorized distributor. This offer and its acceptance are governed by the provisions stated in the detailed "Offer of Sale" elsewhere in this document.



General Information

C Series variable displacement piston pumps have been designed for use in closed circuit hydrostatic applications. The flow direction is controlled by a rugged swash plate and bearing design. Units are rated to operate at pressure up to 420 bar (6090 PSI).

Parker C Series offers a full range of controls:

- Manual lever with feedback
- Hydraulic proportional with or without feedback
- Electric proportional with or without feedback
- Electric on-off
- Electric proportional with hydraulic override
- Automotive

With two cross port relief valves, C Series pumps are protected from pressure overloads. The charge pump circuit features a gerotor pump with three displacement options, while the pump design performs with a variety of accessories, including:

- Hydraulic pressure compensator
- Electric cut-off valve
- Combination hydraulic pressure/electric cut-off
- Flushing valve
- Charge pressure filter with electric or mechanical clogging sensor

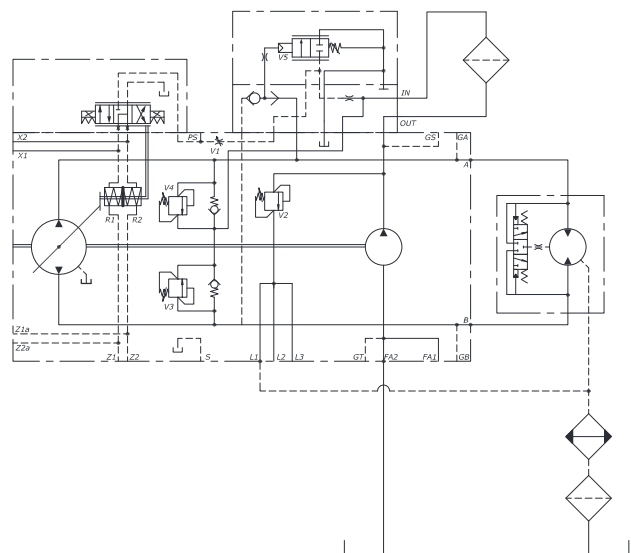


Basic Closed Circuit

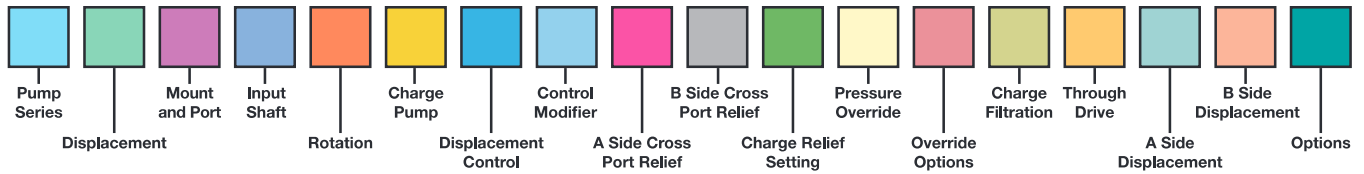
In a closed circuit transmission, both work ports of the hydraulic pump are connected to the hydraulic actuator, typically a hydraulic motor. In a closed circuit transmission, fluid can flow out of either port of the pump to the actuator and return via the opposite port. The position of the swash plate in the pump determines flow direction in the circuit.

The closed circuit pump and actuator will (normally) have case drains which will allow for hot oil to be removed from the circuit for cooling and filtering. Fluid removed from the circuit is replaced by the fluid supplied by the charge pump. The charge pump is a fixed displacement pump, typically a gerotor unit, that's primary purpose is to supply oil into the closed circuit to make up for losses and to provide control flow to the pump displacement controls.

Typical C081 and an F12-060 with Integrated Flushing Valve Option L01



Model Codes



Pump Series	
C	C Series closed circuit pump

Displacement	
055	055 cc/rev (3,35 CIR)
081	081 cc/rev (4,94 CIR)
136	136 cc/rev (8,3 CIR)

Mount and Port Options	
C	SAE C 2/4 bolt mount with SAE ports (C055 and C081 only)
D	SAE D 2/4 bolt mount with SAE ports (C136 only)
G	SAE C 2/4 bolt mount with ISO ports (C055 and C081 only)
H	SAE D 2/4 bolt mount with ISO ports (C136 only)

Rotation	
R	CW (clockwise)
L	CCW (counter clockwise)
As viewed looking at the shaft	

Charge Pump	055	081	136
A	18 cc/rev (1,1 CIR)	#	#
B	23.1 cc/rev (1,41 CIR)	—	X
C	27.3 cc/rev (1,65 CIR)	—	X
D	11 cc/rev (0,67 CIR)	X	—
E	14 cc/rev (0,85 CIR)	X	—
X	No charge pump	X	X

= Standard option
X = Available
— = Not available

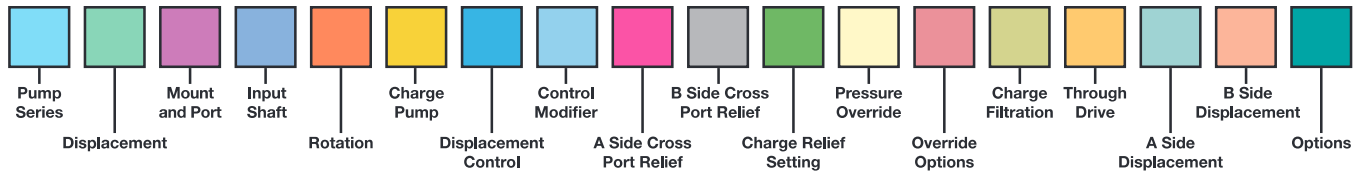
Pump Control	
A	Manual lever
C	Hydraulic proportional control with internal feedback
D	Hydraulic proportional control without internal feedback
E	Electric non proportional
F	Electric proportional with internal feedback
G	Electric proportional without internal feedback
H	Electric proportional with internal feedback and hydraulic override
J	Automotive control electrical
K	Automotive control hydraulic

Input Shaft	055	081	136
1	SAE C 14T 12/24 DP 1 1/4" OD ANSI B92.1a-1976	#	#
2	21T 16/32 DP 1 3/8" OD ANSI B92.1a-1976	X	X
3	SAE D-E 13T 8/16 DP 1 3/4" OD ANSI B92.1a-1976	—	—
4	SAE F 15T 8/16 DP 2" OD ANSI B92.1a-1976	—	—
5	23T 16/32 DP 1 1/2" OD ANSI B92.1a-1976	—	—
6	27T 16/32 DP 1 3/4" OD ANSI B92.1a-1976	—	—
7	W40x2x30x18 DIN 5480	—	—
8	W45x2x30x21 DIN 5480	—	—

= Standard option
X = Available
— = Not available



Model Codes



Pump Control										Control Modifier			
A	C	D	E	F	G	H	J	K		Pump control selection determines what modifier is used			
#	-	A	-	-	-	-	-	-	<->	0	0	0	No control orifices
-	-	X	-	-	-	-	-	-	<->	0	0	5	0.5 mm (.019 in) Control orifice
-	X	X	-	-	-	-	-	-	<->	0	0	6	0.6 mm (.024 in) Control orifice
-	X	X	-	-	-	-	-	-	<->	0	0	7	0.7 mm (.027 in) Control orifice
-	#	X	-	-	-	-	-	-	<->	0	0	8	0.8 mm (.031 in) Control orifice
-	X	#	-	-	-	-	-	-	<->	0	0	9	0.9 mm (.035 in) Control orifice
-	X	X	-	-	-	-	-	-	<->	0	1	2	1.2 mm (.047 in) Control orifice
-	-	-	-	X	-	-	-	-	<->	2	0	0	12 VDC, No control orifice
-	-	-	-	X	-	-	-	-	<->	2	0	6	12 VDC, 0.6 mm (.024 in) Control orifice
-	-	-	-	X	-	-	-	-	<->	2	0	7	12 VDC, 0.7 mm (.027 in) Control orifice
-	-	-	-	#	X	X	-	-	<->	2	0	8	12 VDC, 0.8 mm (.031 in) Control orifice
-	-	-	X	X	-	-	-	-	<->	2	1	2	12 VDC, 1.2 mm (.047 in) Control orifice
-	-	-	-	X	-	-	-	-	<->	2	2	0	12 VDC, 2.0 mm (.079 in) Control orifice
-	-	-	-	X	-	-	-	-	<->	4	0	0	24 VDC, No control orifice
-	-	-	-	X	-	-	-	-	<->	4	0	6	24 VDC, 0.6 mm (.024 in) Control orifice
-	-	-	-	X	-	-	-	-	<->	4	0	7	24 VDC, 0.7 mm (.027 in) Control orifice
-	-	-	-	#	#	#	-	-	<->	4	0	8	24 VDC, 0.8 mm (.031 in) Control orifice
-	-	-	X	X	-	-	-	-	<->	4	1	2	24 VDC, 1.2 mm (.047 in) Control orifice
-	-	-	-	X	-	-	-	-	<->	4	2	0	24 VDC, 2.0 mm (.079 in) Control orifice
-	-	-	-	-	-	-	X	-	<->	D			No inching valve, 12 VDC coils, J control only
-	-	-	-	-	-	-	X	-	<->	E			Hydraulic inching valve, 12 VDC coils, J control only
-	-	-	-	-	-	-	X	-	<->	F			No inching valve, 24 VDC coils, J control only
-	-	-	-	-	-	-	X	-	<->	G			Hydraulic inching valve, 24 VDC coils, J control only
-	-	-	-	-	-	-	-	X	<->	H			Hydraulic inching valve, K control only
-	-	-	-	-	-	-	-	X	<->	X			No inching valve, K control only
-	-	-	-	-	-	-	X	X	<->		2		1.2 mm (.047 in) Control orifice
-	-	-	-	-	-	-	X	X	<->		5		1.5 mm (.059 in) Control orifice
-	-	-	-	-	-	-	X	X	<->			P	Prepared for flushing valve
-	-	-	-	-	-	-	X	X	<->			1	Flushing valve installed with 1.5 mm orifice
-	-	-	-	-	-	-	X	X	<->			2	Flushing valve installed with 2.0 mm orifice
-	-	-	-	-	-	-	X	X	<->			3	Flushing valve installed with 2.5 mm orifice
# = Standard option X = Available - = Not available A = Without pressure override only										Example modifier with J/K control			
										G	5	P	Hydraulic inching valve, 24VDC coils with a 1.5 mm control orifice and prepared for flushing
										When ordering J/K control specify starting input RPM, input RPM at rated torque and rated input torque (NM)			

A Side Cross Port Relief	
A	250 Bar (3625 PSI)
B	350 Bar (5075 PSI)
C	420 Bar (6090 PSI)
D	450 Bar (6525 PSI)

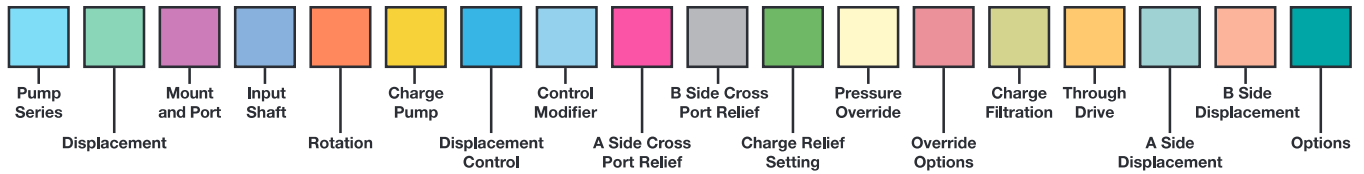
B Side Cross Port Relief	
A	250 Bar (3625 PSI)
B	350 Bar (5075 PSI)
C	420 Bar (6090 PSI)
D	450 Bar (6525 PSI)

Charge Relief Setting		055	081	136
A	20 Bar (290 PSI)	X	X	-
B	22 Bar (319 PSI)	#	#	#
C	25 Bar (362 PSI)	X	X	X

= Standard option
 X = Available
 - = Not available



Model Codes



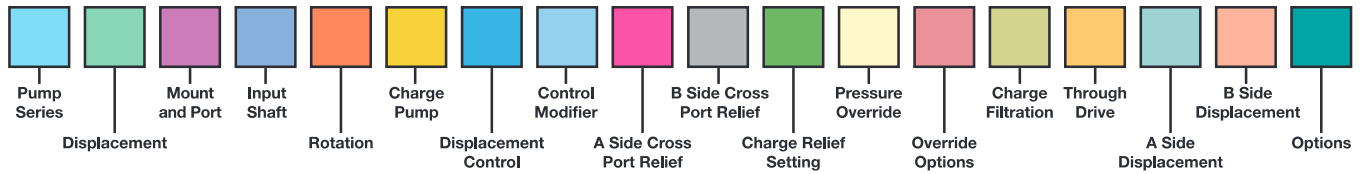
Pressure Override	
X	No pressure override
P	Hydraulic internal pressure override
E	Electrical override
C	Electrical override and hydraulic internal pressure override
Override not available on J/K control. Pressure override should be set 20-30 bar below cross port relief settings.	

Pressure Override					Override Options		
X	P	E	C		Pressure override selection determines override option		
X	—	—	—	<=>	X	X	No pressure override
—	X	—	—	<=>	0	A	Locked
—	X	—	—	<=>	0	B	100 Bar (1450 PSI)
—	X	—	—	<=>	0	C	150 Bar (2175 PSI)
—	X	—	—	<=>	0	D	200 Bar (2900 PSI)
—	X	—	—	<=>	0	E	250 Bar (3625 PSI)
—	X	—	—	<=>	0	F	280 Bar (4060 PSI)
—	X	—	—	<=>	0	G	300 Bar (4350 PSI)
—	X	—	—	<=>	0	H	320 Bar (4712 PSI)
—	X	—	—	<=>	0	J	330 Bar (4785 PSI)
—	X	—	—	<=>	0	K	350 Bar (5075 PSI)
—	X	—	—	<=>	0	M	380 Bar (5510 PSI)
—	X	—	—	<=>	0	N	400 Bar (5800 PSI)
—	—	X	—	<=>	1	2	12 VDC coil
—	—	X	—	<=>	2	4	24 VDC coil
—	—	—	X	<=>	2	A	12VDC coil locked override
—	—	—	X	<=>	2	B	12VDC coil, 100 Bar (1450 PSI) override
—	—	—	X	<=>	2	C	12VDC coil, 150 Bar (2175 PSI) override
—	—	—	X	<=>	2	D	12VDC coil, 200 Bar (2900 PSI) override
—	—	—	X	<=>	2	E	12VDC coil, 250 Bar (3625 PSI) override
—	—	—	X	<=>	2	G	12VDC coil, 300 Bar (4350 PSI) override
—	—	—	X	<=>	2	K	12VDC coil, 350 Bar (5075 PSI) override
—	—	—	X	<=>	2	M	12VDC coil, 380 Bar (5510 PSI) override
—	—	—	X	<=>	2	N	12VDC coil, 400 Bar (5800 PSI) override
—	—	—	X	<=>	4	A	24 VDC coil locked override
—	—	—	X	<=>	4	B	24 VDC coil, 100 Bar (1450 PSI) override
—	—	—	X	<=>	4	C	24 VDC coil, 150 Bar (2175 PSI) override
—	—	—	X	<=>	4	D	24 VDC coil, 200 Bar (2900 PSI) override
—	—	—	X	<=>	4	E	24 VDC coil, 250 Bar (3625 PSI) override
—	—	—	X	<=>	4	G	24 VDC coil, 300 Bar (4350 PSI) override
—	—	—	X	<=>	4	K	24 VDC coil, 350 Bar (5075 PSI) override
—	—	—	X	<=>	4	M	24 VDC coil, 380 Bar (5510 PSI) override
—	—	—	X	<=>	4	N	24 VDC coil, 400 Bar (5800 PSI) override

X = Available
— = Not available



Model Codes



Charge Filtration		055	081	136
X	No charge filter	#	#	#
N	Charge filter with 8 Bar (116 PSI) mechanical bypass indicator	X	X	X
G	Charge filter with 8 Bar (116 PSI) electrical bypass indicator	X	X	X
R	Prepared for remote charge pressure filtration	X	X	X

= Standard option
X = Available
— = Not available

A Side Displacement	
00-99	Set displacement of A side between 0-99%
XX	XX = 100% displacement

B Side Displacement	
00-99	Set displacement of B side between 0-99%
XX	XX = 100% displacement

Options		055	081	136
X	No paint, no bypass valve	#	#	#
Y	No paint with bypass valve	X	X	—
P	Paint black, no bypass valve	X	X	X
D	Paint black with bypass valve	X	X	—
M	Special modification contact technical support			

= Standard option
X = Available all displacements
— = Not available

Through Drive		055	081	136
X	No through drive	#	#	#
A	SAE A mount, 9T spline shaft	X	X	X
B	SAE B mount, 13T spline shaft	X	X	X
G	SAE B mount, 15T spline shaft	X	X	X
C	SAE C mount, 14T spline shaft	X	X	X
H	SAE C mount, 17T spline shaft	X	X	X
D	SAE D mount, 13T spline shaft	X	X	X

= Standard option
X = Available
— = Not available

Example Model Code

C081C1RAF208BBBP0HRAXXXP

- C081** = 81cc frame
- C** = SAE C 2/4 bolt mount with SAE ports
- 1** = SAE C 14T 12/24 DP 1-1/4" OD ANSI B92.1A-1976
- R** = CW rotation (looking at the shaft)
- A** = 81cc frame 18cc/rev (1.1 CIR) charge pump
- F** = Electric proportional with internal feedback displacement control
- 208** = 12 VDC, 0.8mm (.031 in) control orifice
- B** = A side cross port relief set to 350 bar (5075 PSI)
- B** = B side cross port relief set to 350 bar (5075 PSI)
- B** = Charge relief set to 22 bar (319 PSI)
- P** = Hydraulic internal pressure override
- 0H** = Pressure override set to 320 bar (4712 PSI)
- R** = Prepared for remote charge pressure filtration
- A** = SAE A mount through drive with 9T spline shaft coupling
- XX** = A side displacement set to 100%
- XX** = B side displacement set to 100%
- P** = Paint black, no bypass valve

Technical Data

Fluids

Only fluids with mineral oil basis and anticorrosive, antioxidant and wear-preventing agents (HL or HM) should be used. Viscosity range at operating temperature must be between 15 and 40 cSt. For short periods and low starting temperatures, a maximum viscosity of 800 cSt is allowed. Viscosities less than 10 cSt are not permitted. In extreme operating conditions, a viscosity range of 10 to 15 cSt is allowed for short periods.

Operating Temperature

The oil's operating temperature must be between -13°F and 194°F (-25°C and 90°C). Running the unit outside of these temperature ranges is not recommended, and could negatively impact performance.

Filtration

The C Series pump is available with a built-in charge filter. Units also can be shipped with a block to permit a remote-mounted filter. Parker suggests a remote pressure filter with an element rating of 10 micron absolute and a minimum beta ratio of 200. A visual or electromechanical indicator is also suggested.

Correct filtration helps extend unit life. The maximum permissible contamination class is 20/18/15 per ISO 4406:1999. Suction filters are not suggested. If needed, a 100-mesh (149-micron) strainer is the finest mesh recommended.

Suction Pressure

The charge pump suction performs at a minimum absolute pressure of 0.8 bar (11.6 psi). For short periods and low starting temperatures, an absolute pressure of 0.5 bar (7.25 psi) is allowed. Inlet pressure may never be lower.

Operating Pressure

Main pump: The maximum permissible continuous pressure is 420 bar (6,090 psi).

Charge pump: Nominal pressure is 25 bar (360 psi). Maximum admissible pressure is 40 bar (580 psi).

Case Drain Pressure

Maximum case drain pressure is 4 bar (58 psi). For short periods and low starting temperatures, a pressure of 6 bar (86 psi) is allowed. Higher pressures can damage the input shaft seal, reducing its life.

Seals

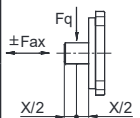
Parker C Series pumps use standard FKM (Viton®) seals. In case of special fluids, contact your Parker distributor.

Displacement Limiting

An externally adjustable mechanical device limits displacement by utilizing two setting screws to limit to the control piston stroke.

Input Shaft: Radial and Axial Loads

The input shaft can stand both radial and axial loads. Maximum permissible loads in the following table are calculated to guarantee a service life of at least 80% of that of bearings to which no load has been applied.

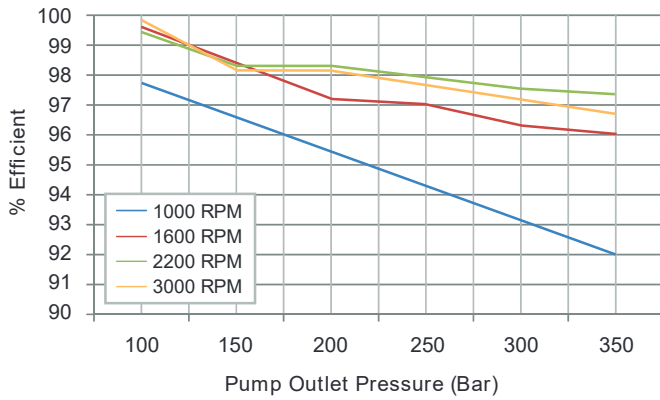
Displacement				C055	C081	C136
	Radial Load	F _q max	N (lbf)	1900 (428)	2400 (540)	4600 (1035)
	Axial Load	F _{ax} max	N (lbf)	1500 (337)	3000 (674)	4000 (899)



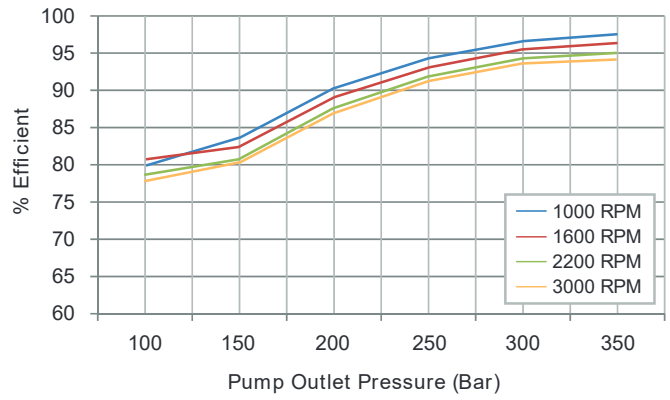
C Series Technical Specifications			
Frame	C055	C081	C136
Displacement CC/Rev (CIR)	55 (3.35)	81 (4.94)	136 (8.3)
Input Speed (RPM)			
Continuous	3800	3400	2850
Intermittent	4000	3600	3250
Minimum	500	500	500
System Pressure Bar (PSI)			
Continuous	420 (6090)		
Peak*	450 (6525)*		
Charge Inlet Pressure Bar (PSI) Absolute			
Minimum	.8 (11.6)		
Cold Startup	.5 (7.25)		
Case Pressure Bar (PSI)			
Maximum Continuous	4 (58)		
Cold Startup	6 (86)		
Fluid Viscosity cSt			
Operating	15 to 40		
Minimum	10		
Cold Startup	800		
Fluid Operating Temperature °F (°C)	-13 to 194°F (-25 to 90°C)		
Maximum Permissible Fluid Cleanliness Per ISO 4406:1999	20/18/15		
Power Consumption kW (HP)			
Continuous	146 (196)	170 (228)	259 (347)
Peak	165 (221)	203 (272)	343 (459)
Maximum Torque at Maximum Displacement Nm (lb-ft)			
Continuous	368 (271)	478 (352)	858 (632)
Peak	394 (291)	537 (396)	980 (722)
Moment of Inertia Kg-m² (lbf-ft²)	.0064 (.156)	.014 (.34)	.040 (.96)
Approximate Weight kg (lb)	46 (101)	51 (113)	86 (190)

*Peak is defined as no longer than 1% of every minute. For long life, design system to not run at maximum flow and pressure continuously.

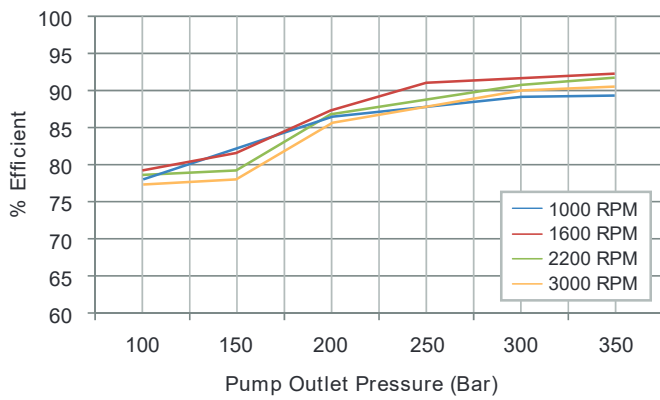
C055 Volumetric Efficiency



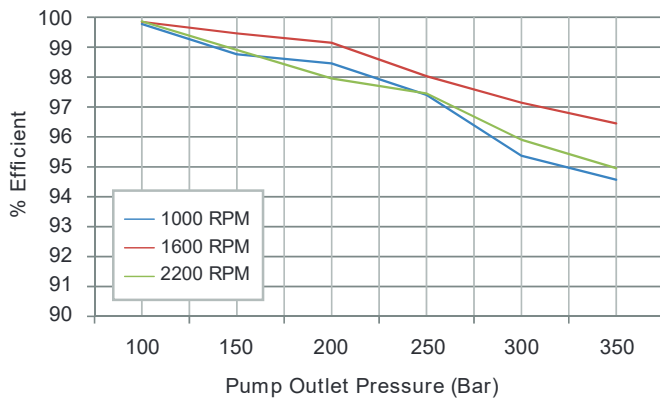
C055 Mechanical Efficiency



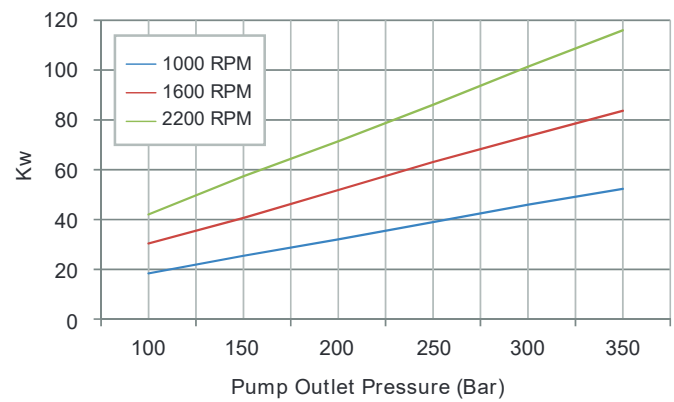
C055 Overall Efficiency



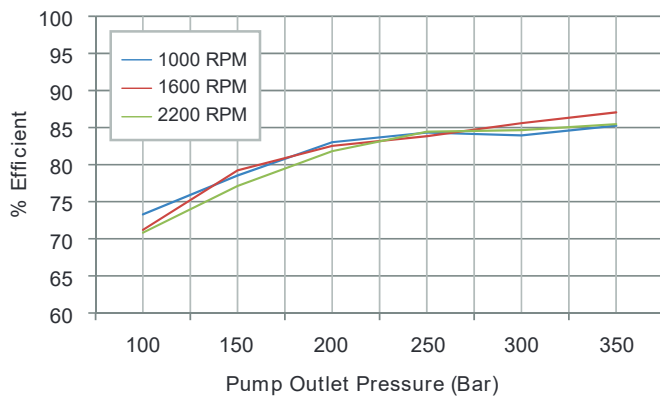
C081 Volumetric Efficiency



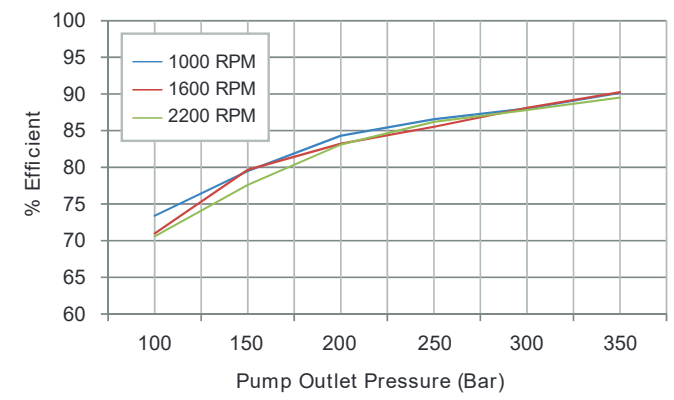
C081 Input Power



C081 Overall Efficiency

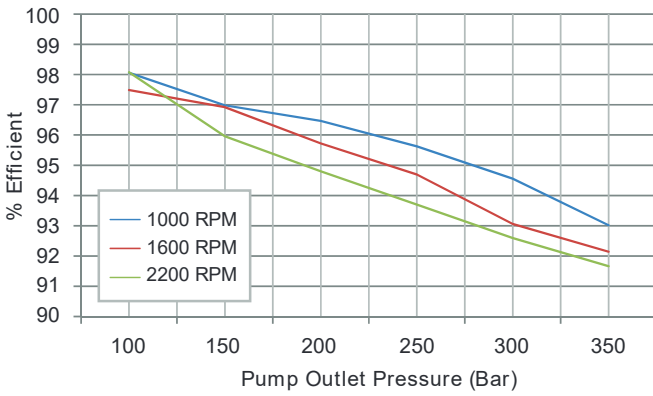


C081 Mechanical Efficiency

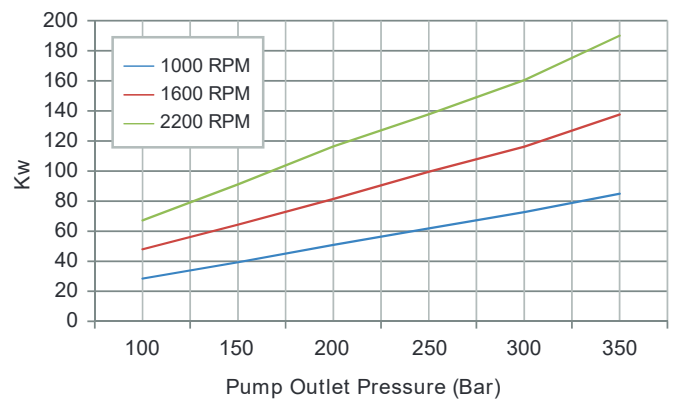


Testing completed using ISO VG68 fluid at 90°C 18 cc charge pump with 22 bar pressure setting

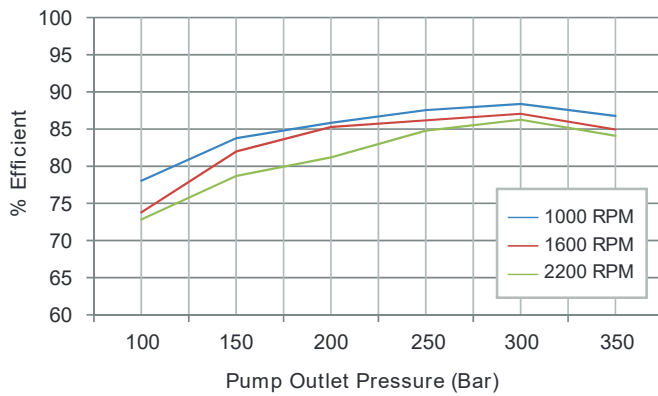
C136 Volumetric Efficiency



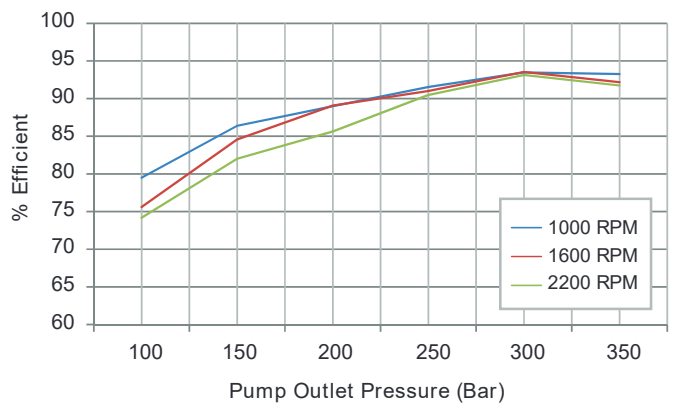
C136 Input Power



C136 Overall Efficiency



C136 Mechanical Efficiency

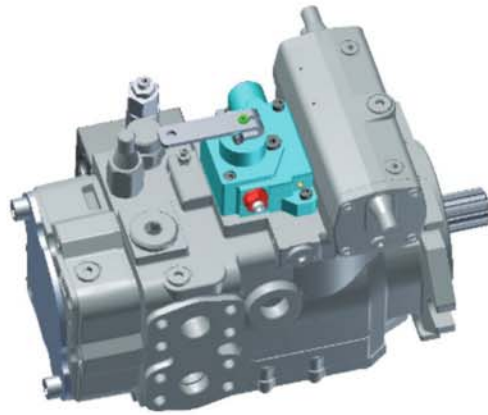


Testing completed using ISO VG68 fluid at 90°C 23 cc charge pump with 22 bar pressure setting

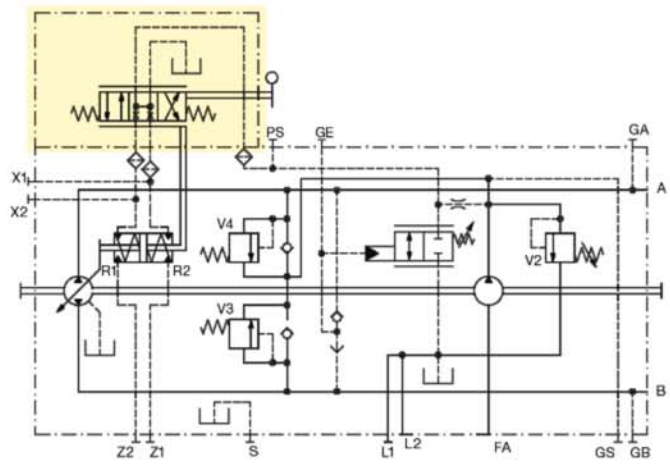
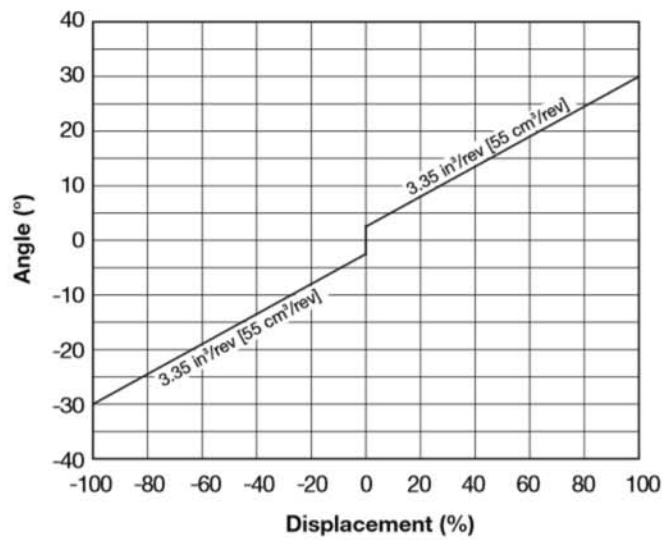


Manual Lever Control With Feedback – A

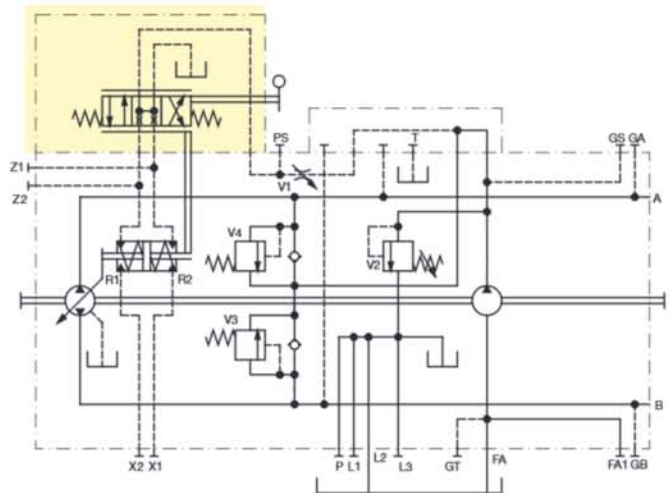
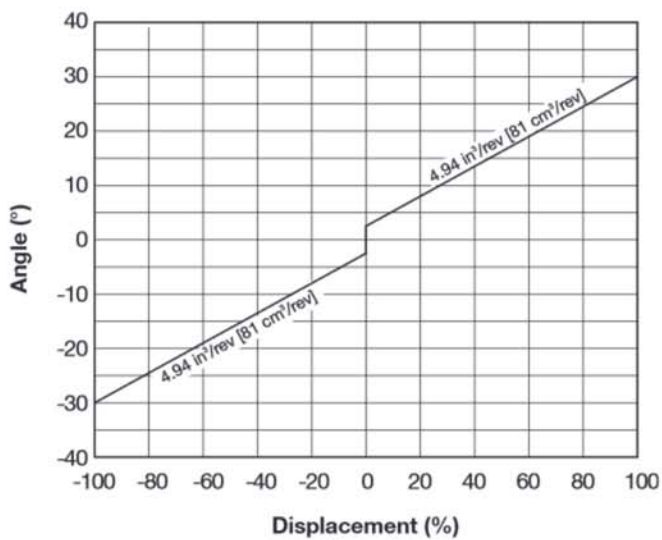
Pump displacement is directly proportional to the lever's rotation angle. Based on swash-plate position, the feedback system works automatically to compensate for positioning errors. Refer to diagrams for relationship between angle and displacement.



C055 Lever Angle vs. Displacement

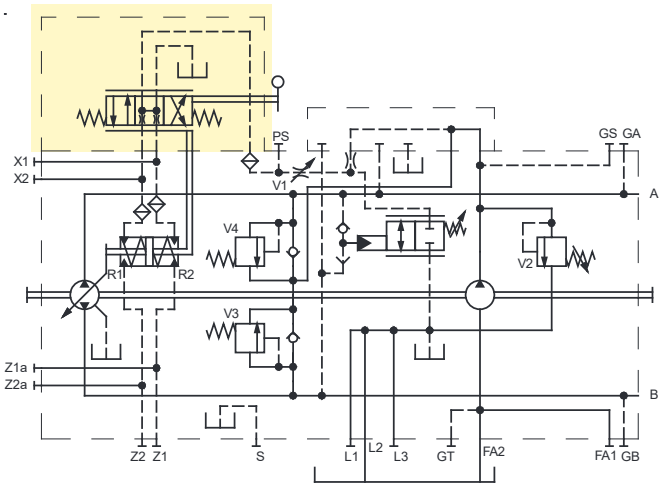
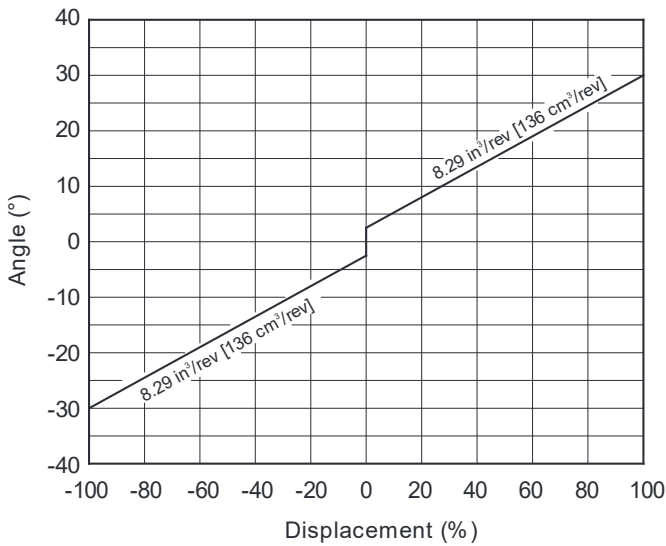


C081 Lever Angle vs. Displacement

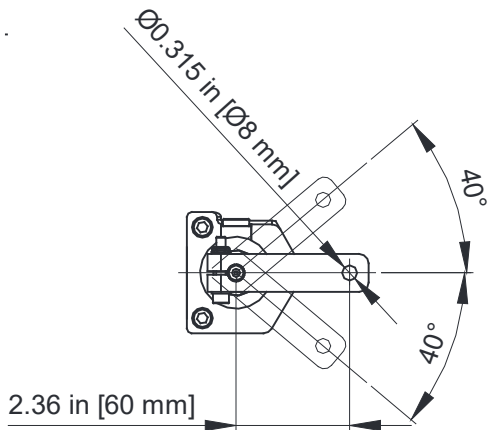


Controls

C136 Lever Angle vs. Displacement



Lever Detail

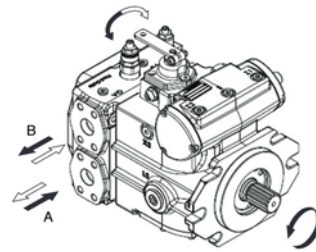


Lever width = .75 in [20 mm]
 Lever thickness = .16 in [4 mm]
 The torque necessary at the control lever is between 1 and 2.45 Nm [0.737 and 1.80 lbf-ft].

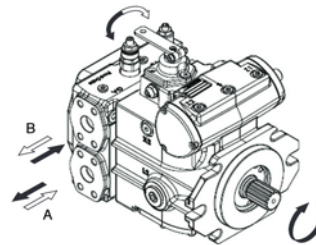
NOTE:

The spring return feature in the control unit is not a safety device. Internal contamination (contaminated hydraulic fluid, abrasion or residual contamination from system components) can cause the spool valve inside the control unit to get stuck in an undefined position. As a result, the axial piston unit will no longer supply the specified flow. Check which remedial measures should be taken on your machine in order to bring the driver consumer into a safe position (e.g. immediate stop).

Direction of Rotation



L (CCW) Rotation

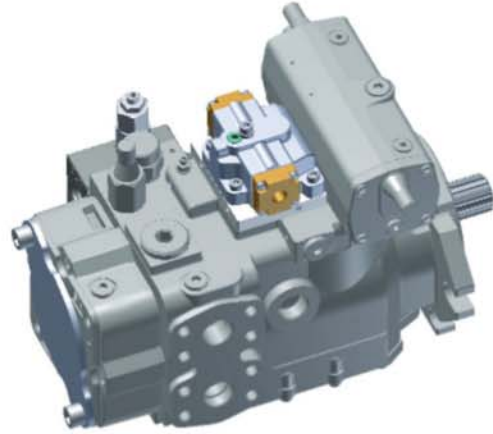


R (CW) Rotation

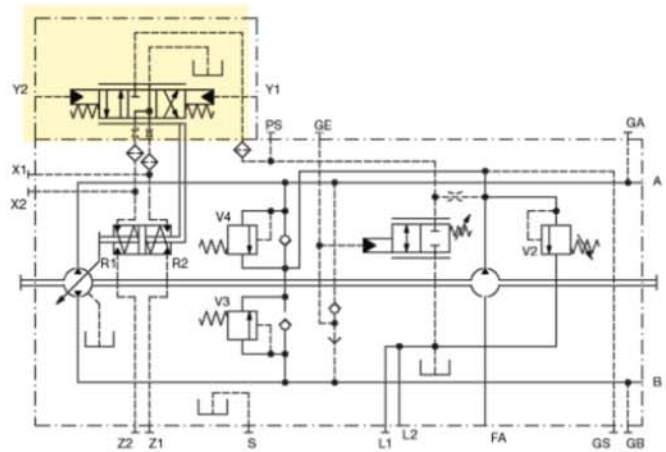
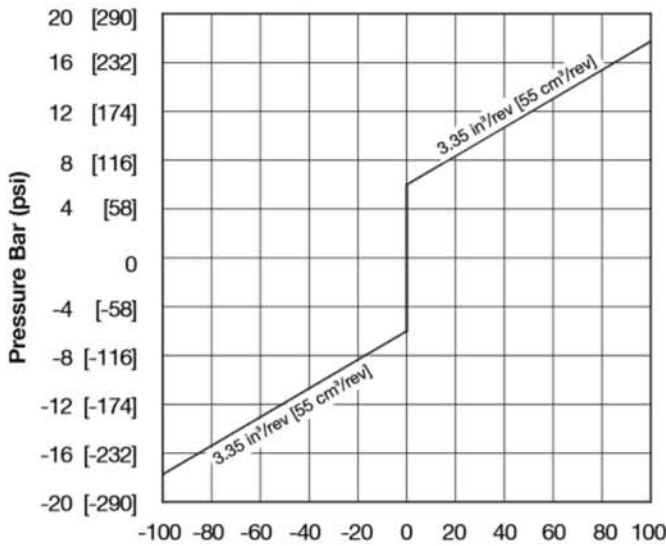
Correlation between direction of rotation (shaft view) control and direction of flow.

**Hydraulic Proportional Control
 With Feedback – C**

Pump displacement and flow direction are proportional to the pilot pressure on Y1 or Y2 ports. Based on swash-plate position, the feedback system works automatically to compensate for positioning errors. Piloting can be provided by boost pressure from the GS port. The piloting pressure must then be controlled by a joystick or pressure-reducing valve (not supplied).

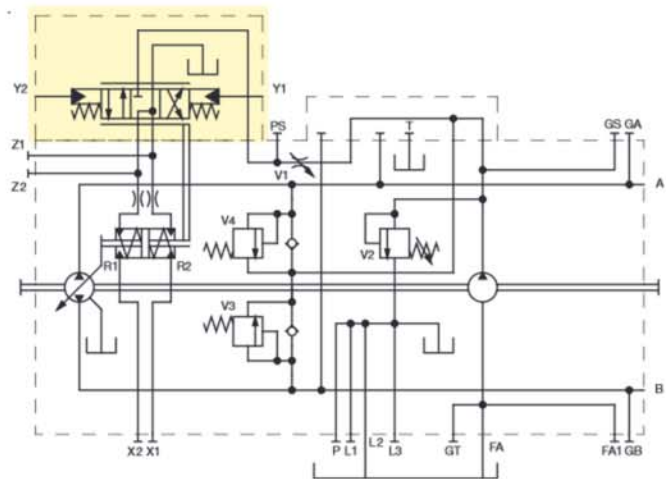
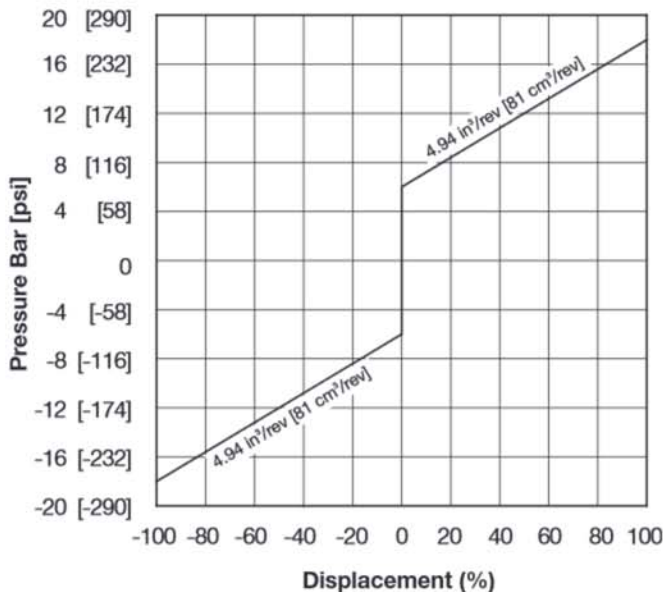


C055 Pilot Pressure vs. Displacement



Pilot pressure = 6÷18 bar [87÷261 psi] (at ports Y1, Y2)
 Start of control = 6 bar [87 psi]
 End of control = 18 bar [261 psi] (Max displacement)

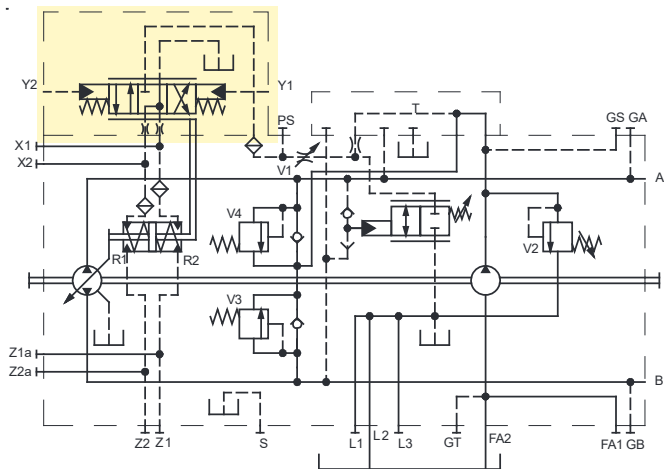
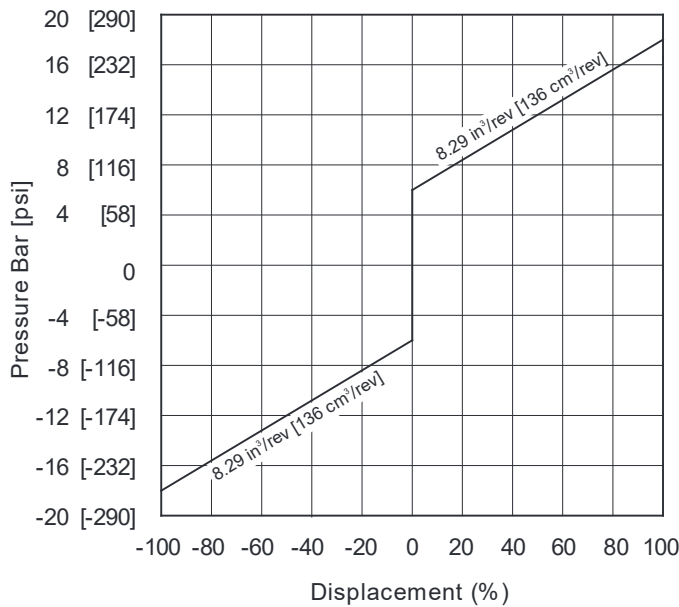
C081 Pilot Pressure vs. Displacement



Pilot pressure = 6÷18 bar [87÷261 psi] (at ports Y1, Y2)
 Start of control = 6 bar [87 psi]
 End of control = 18 bar [261 psi] (Max displacement)

Controls

C136 Pilot Pressure vs. Displacement

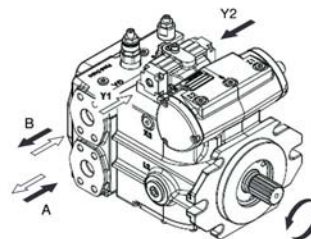


NOTE:

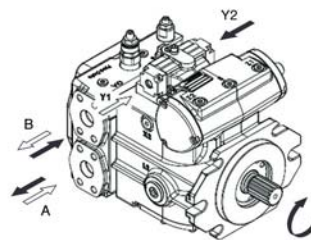
The tolerance on piloting pressure is $\pm 10\%$ of maximum value.

The spring return feature in the control unit is not a safety device. Internal contamination (contaminated hydraulic fluid, abrasion or residual contamination from system components) can cause the spool valve inside the control unit to get stuck in an undefined position. As a result, the axial piston unit will no longer supply the specified flow. Check which remedial measures should be taken on your machine in order to bring the driver consumer into a safe position (e.g. immediate stop).

Direction of Rotation



L (CCW) Rotation



R (CW) Rotation

Correlation between direction of rotation (shaft view) control and direction of flow.

Control Response Time		
Orifice dimension	Vg min → Vg max 300 bar [4350 psi]	Vg max → Vg min 300 bar [4350 psi]
Ø 0.5 mm [Ø 0.019 in]	3.6 sec.	6.5 sec.
Ø 0.7 mm (*) [Ø 0.027 in] (*)	2 sec.	3.1 sec.
Ø 0.8 mm (**) [Ø 0.031 in] (**)	1.7 sec.	2.7 sec.
Ø 0.9 mm [Ø 0.035 in]	1.6 sec.	2.2 sec.

Values obtained with oil temperature 45°+47°C and pump temperature of 50°+ 55°C – oil ISO Vg 46.

(*) STANDARD with override valves

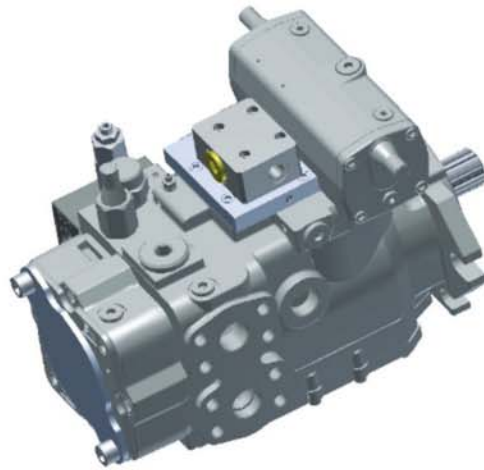
(**) STANDARD without override valves, Note: Used on C081 only



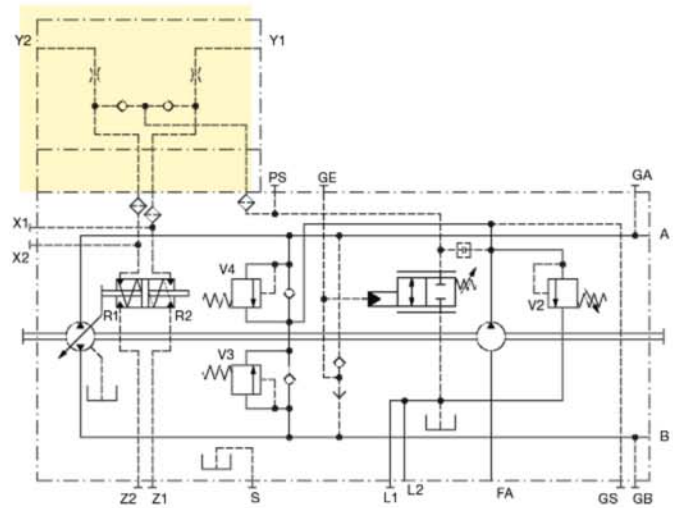
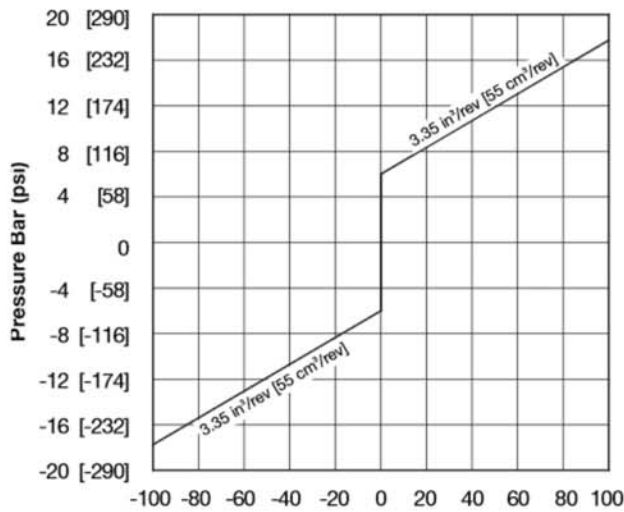
Controls

Hydraulic Proportional Control Without Feedback – D

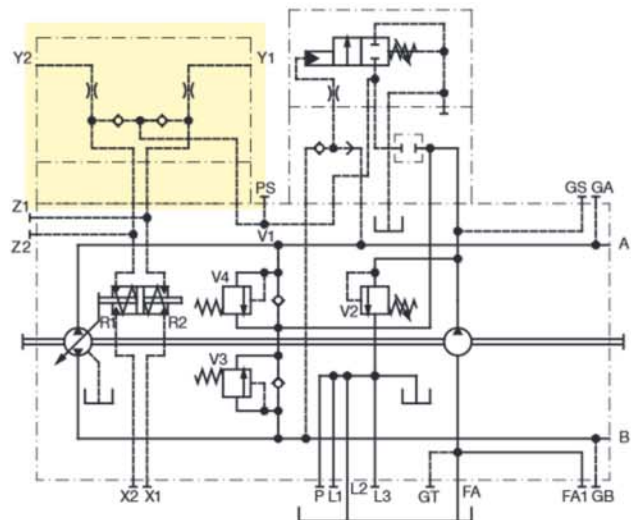
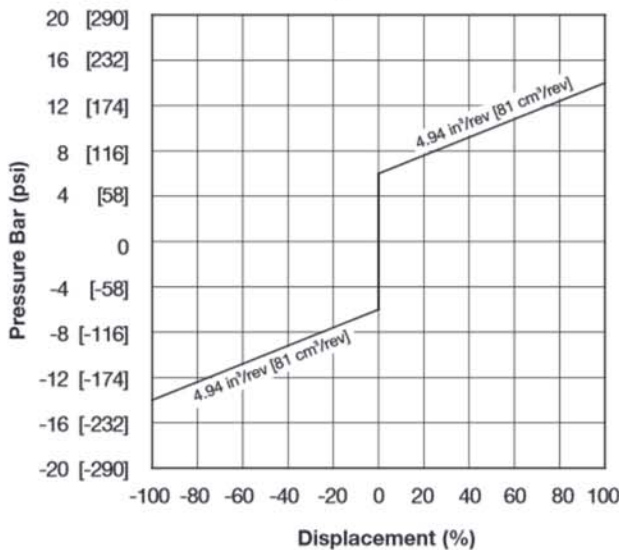
Pump displacement and flow direction are proportional to the pilot pressure on Y1 or Y2 ports. Working pressure and rotation speed also influence flow. With a given input signal (piloting pressure), the pump can vary displacement and flow when working pressure or rotating speed change. Feeding pressure to the control joystick can be provided by charge pressure from the GS port. The piloting pressure must then be controlled by said joystick or by a pressure-reducing valve (not supplied). The orifice dimensions must correlate with required response times. See next page for table.



C055 Pilot Pressure vs. Displacement



C081 Pilot Pressure vs. Displacement

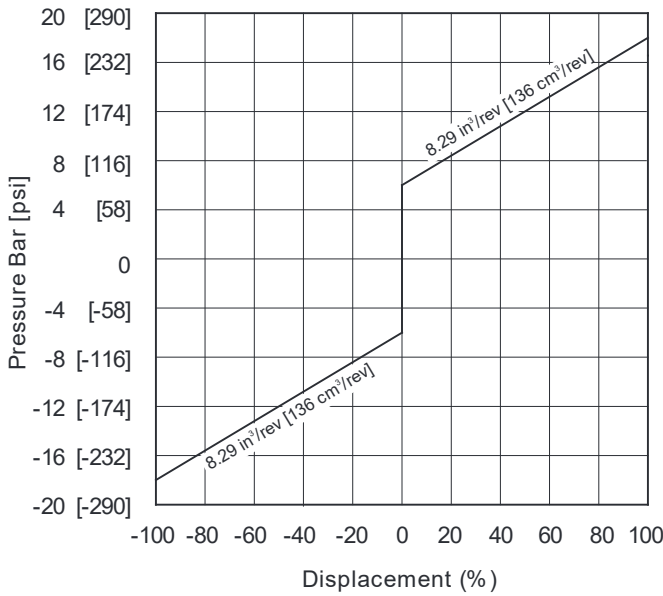


Pilot pressure = 6÷14 bar [87÷203 psi] (at ports Y1, Y2)
 Maximum pilot pressure = 30 bar [435 psi]
 Start of control = 6 bar [87 psi]
 End of control = 14 bar [203 psi] (Max displacement)

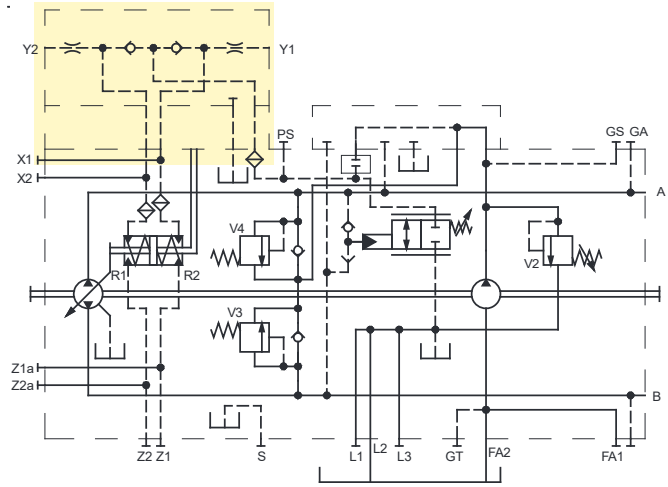
Nominal output shown. Actual output will vary depending on input speed and system pressures.

Controls

C136 Pilot Pressure vs. Displacement



Nominal output shown. Actual output will vary depending on input speed and system pressures.



Pilot pressure = 6±14 bar [87±203 psi] (at ports Y1, Y2)
 Maximum pilot pressure = 30 bar [435 psi]
 Start of control = 6 bar [87 psi]
 End of control = 14 bar [203 psi] (Max displacement)

Control Response Time		
Orifice dimension	Vg min→ Vg max 300 bar [4350 psi]	Vg max→ Vg min 300 bar [4350 psi]
Ø 0.5 mm [Ø 0.019 in]	3.6 sec.	6.5 sec.
Ø 0.7 mm (*) [Ø 0.027 in] (*)	2 sec.	3.1 sec.
Ø 0.8 mm (**) [Ø 0.031 in] (**)	1.7 sec.	2.7 sec.
Ø 0.9 mm [Ø 0.035 in]	1.6 sec.	2.2 sec.
Values obtained with oil temperature 45°±47°C and pump temperature of 50°±55°C – oil ISO Vg 46.		

(*) STANDARD with override valves
 (**) STANDARD without override valves, Note: Used on C081 only

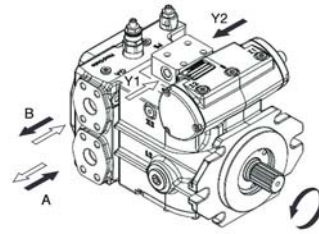
NOTE:

The tolerance on piloting pressure is ± 10% of maximum value.

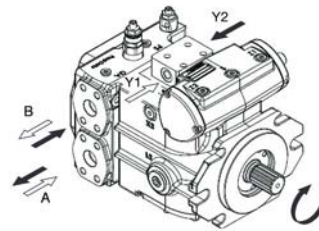
WARNING:

Use of the D control can require a review of the motor engine and vehicle parameters to ensure that the pump is set up correctly. We recommend that applications be reviewed by a Parker technician.

Direction of Rotation



L (CCW) Rotation



R (CW) Rotation

Correlation between direction of rotation (shaft view) control and direction of flow.



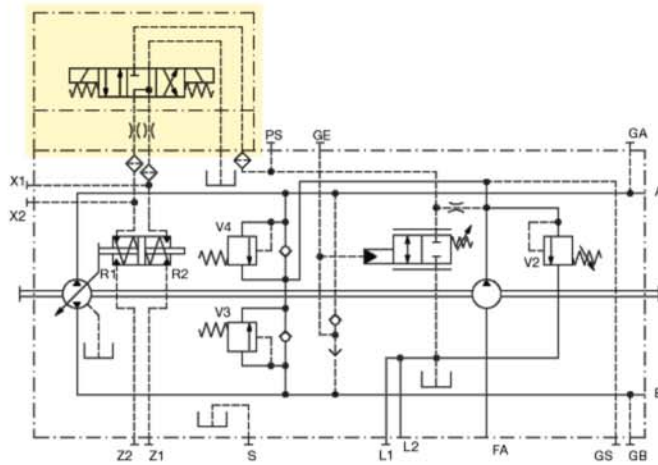
Controls

Electric Non-Proportional – E

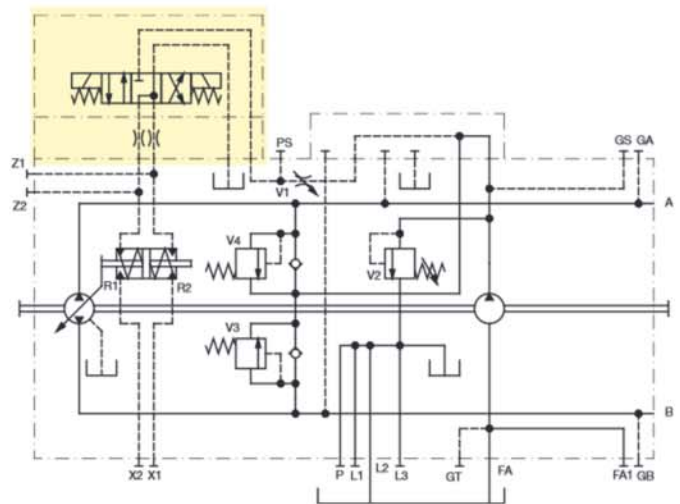
By turning on one of the on-off solenoids (standard 24V d.c. optional 12V d.c.), the pump swivels to maximum displacement in the corresponding output flow direction. Turning off the solenoid results in swiveling the pump back to zero displacement position.



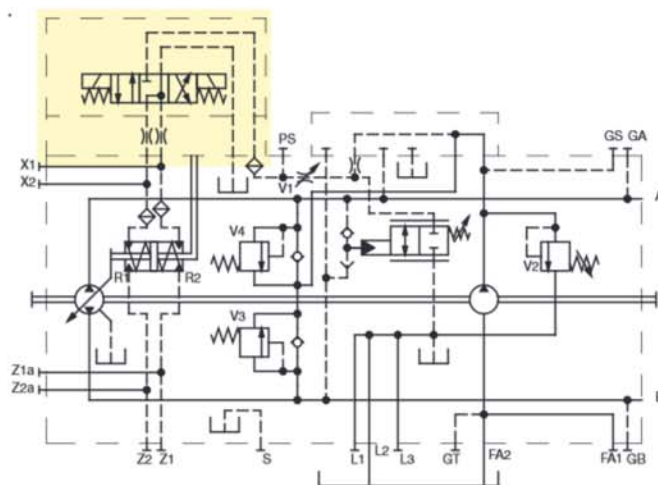
C055



C081

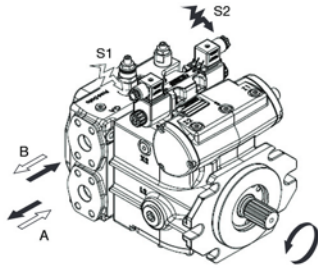


C136

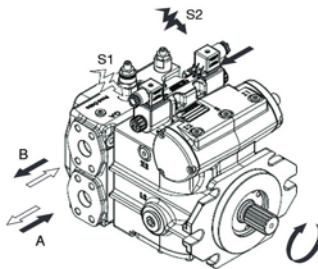


Controls

Direction of Rotation



L (CCW) Rotation



R (CW) Rotation

Correlation between direction of rotation (shaft view) control and direction of flow.

NOTE:

The tolerance on control coil amperage is $\pm 10\%$ of maximum value.

30 Watt coils

12 VDC coil resistance of 18.8 ohms

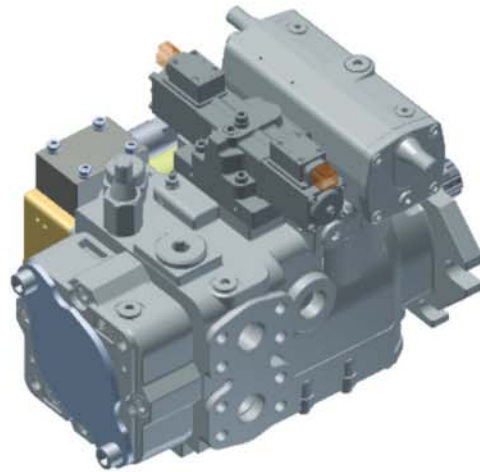
24 VDC coil resistance of 18.8 ohms

The spring return feature in the control unit is not a safety device. Internal contamination (contaminated hydraulic fluid, abrasion or residual contamination from system components) can cause the spool valve inside the control unit to get stuck in an undefined position. As a result, the axial piston unit will no longer supply the specified flow. Check which remedial measures should taken on your machine in order to bring the driver consumer into a safe position (e.g. immediate stop).

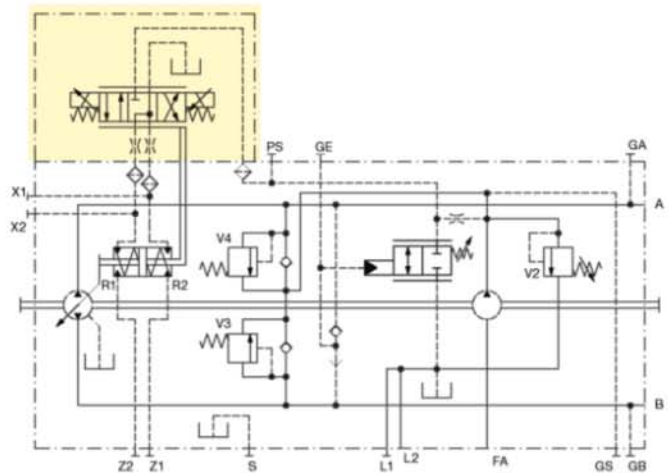
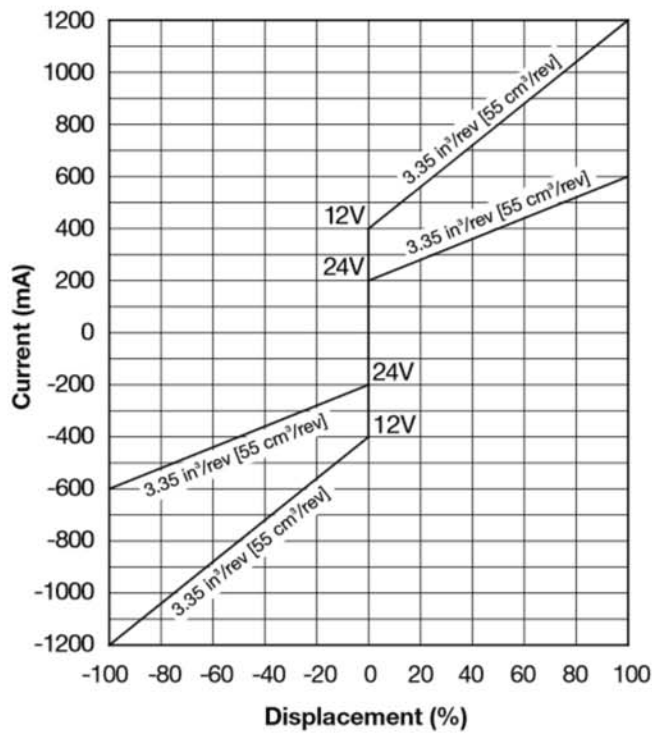
Electric Proportional Control With Feedback – F

Pump displacement is directly proportional to the input current of one of the two proportional solenoids. Based on swash-plate position, the feedback system works automatically to compensate for positioning errors. The input current of the two proportional solenoids must be controlled by an external amplifier card. The Parker IQAN family of controllers is suggested for use.

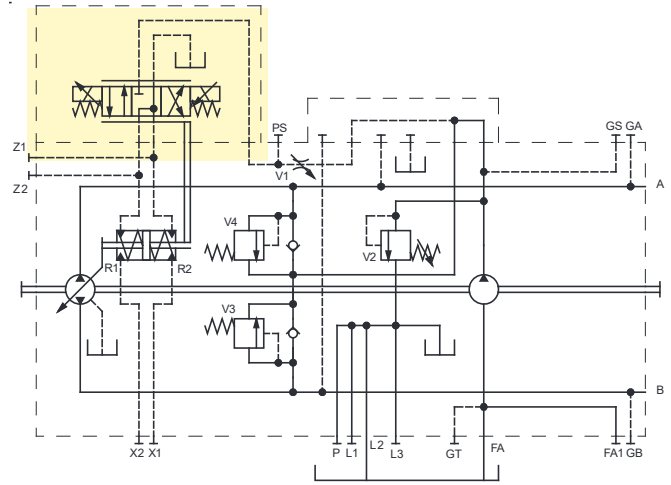
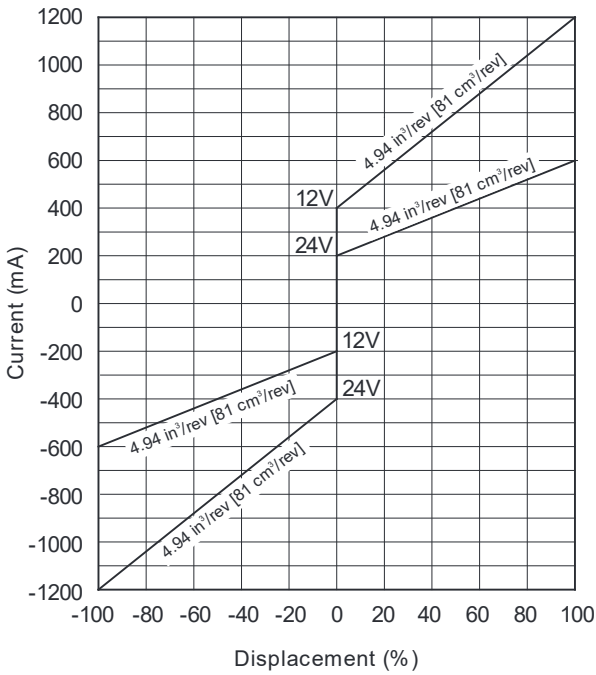
Flow direction depends on which solenoid is energized. Standard solenoids are proportional at 24V d.c. max. current 1A. (Optional solenoids 12Vmd.c. max. current 2A). However, for emergency operation only, it is possible to control solenoids directly with 24V d.c. voltage (or 12V d.c.), bypassing the amplifier.



C055 Amperage vs. Displacement

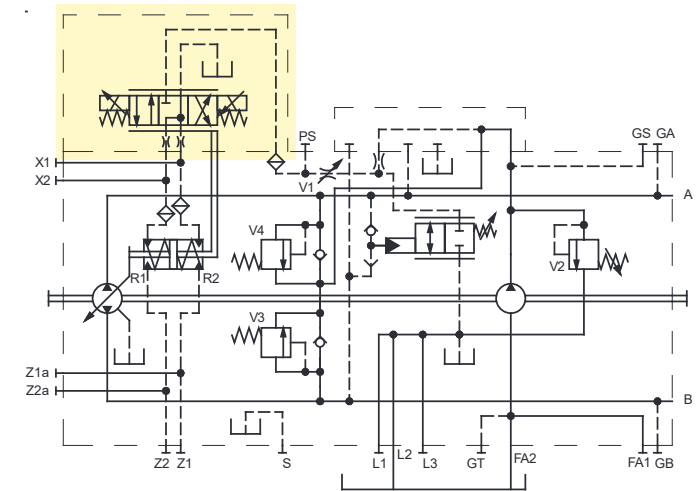
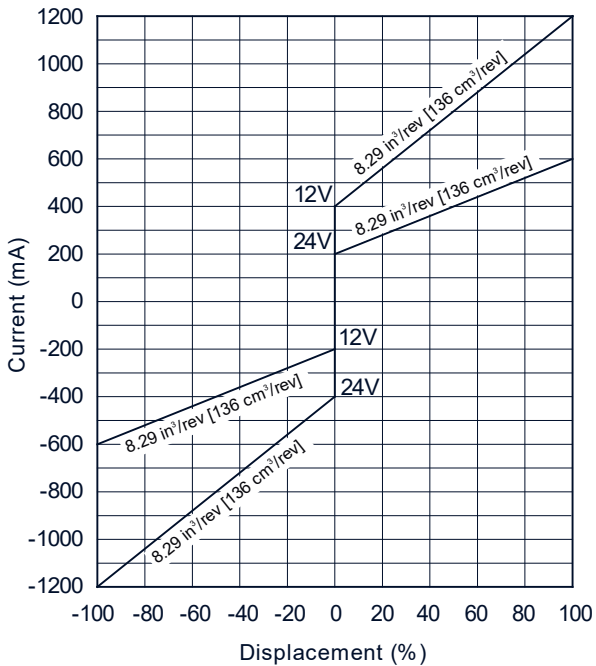


C081 Amperage vs. Displacement



Solenoid 24V: Current min. 200 mA max 600 mA
 Solenoid 12V: Current min. 400 mA max 1200 mA
 PWM frequency: 110 Hz

C136 Amperage vs. Displacement



Solenoid 24V: Current min. 200 mA max 600 mA
 Solenoid 12V: Current min. 400 mA max 1200 mA
 PWM frequency: 110 Hz

Controls

C055 and C081 Step Response Chart					
Orifice size	0.6 mm	0.7 mm	0.8* mm	1.2 mm	None
0 to full flow	5.87	4.48	4.27	3.09	2.88
Full to 0 flow	3.52	2.99	2.56	1.17	0.96

C136 Step Response Chart					
Orifice size	0.6 mm	0.7 mm	0.8* mm	1.2 mm	None
0 to full flow	8.22	6.40	5.44	3.63	3.20
Full to 0 flow	4.69	3.63	2.88	1.60	1.07

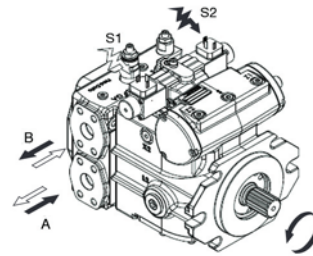
Time in seconds
 *Standard orifice
 Fluid viscosity = 50 cSt
 Input speed = 1500
 250 bar (3600 PSI) working pressure
 22 bar (320 PSI) charge pressure

NOTE:

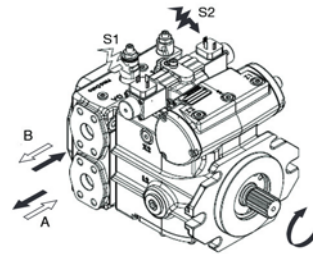
The tolerance on control coil amperage is ± 10% of maximum value.

The spring return feature in the control unit is not a safety device. Internal contamination (contaminated hydraulic fluid, abrasion or residual contamination from system components) can cause the spool valve inside the control unit to get stuck in an undefined position. As a result, the axial piston unit will no longer supply the specified flow. Check which remedial measures should taken on your machine in order to bring the driver consumer into a safe position (e.g. immediate stop).

Direction of Rotation



L (CCW) Rotation



R (CW) Rotation

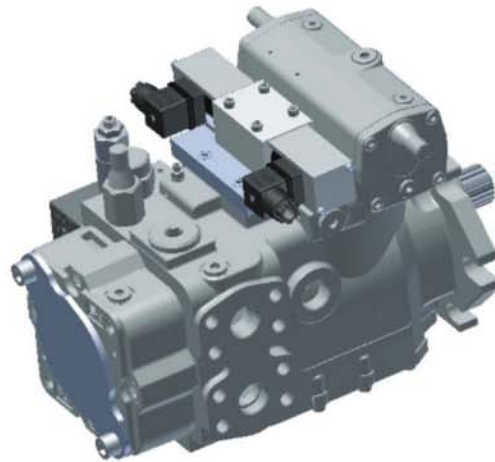
Correlation between direction of rotation (shaft view) control and direction of flow.

Controls

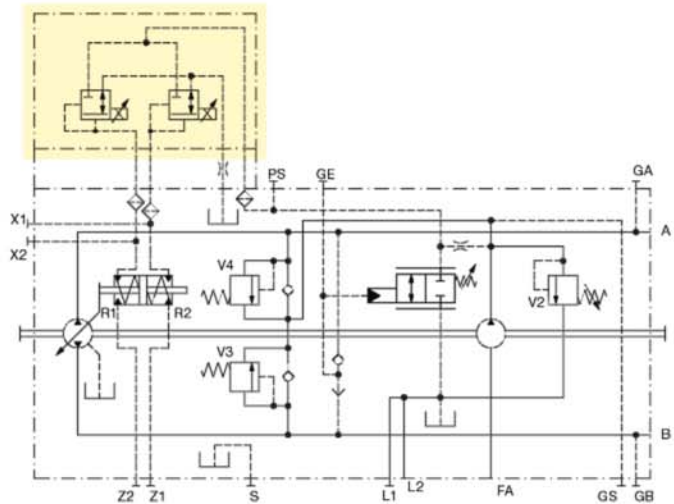
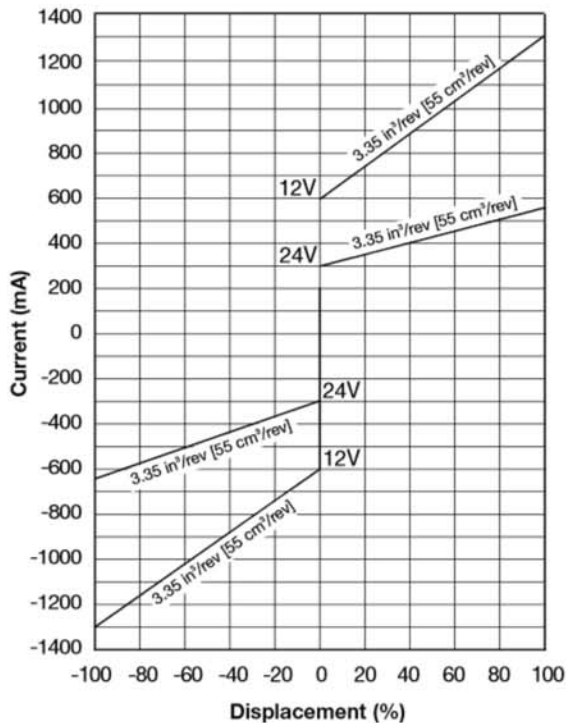
Electric Proportional Control Without Feedback – G

Pump displacement is directly proportional to the input current of the two proportional solenoids. Flow is also influenced by the working pressure and rotation speed of the pump. With a given input signal (piloting current), the pump can vary the displacement and flow when working pressure or rotating speed change. The input current of the two proportional solenoids must be controlled by an external amplifier card. The Parker IQAN family of controllers is suggested for use.

Flow direction depends on which solenoid is energized. Standard solenoids are proportional 24V d.c. max. current 1A. (Optional solenoids 12V d.c. max. current 2A). However, for emergency operation only, it is possible to control solenoids directly with 24V d.c. voltage (or 12V d.c.), bypassing the amplifier.

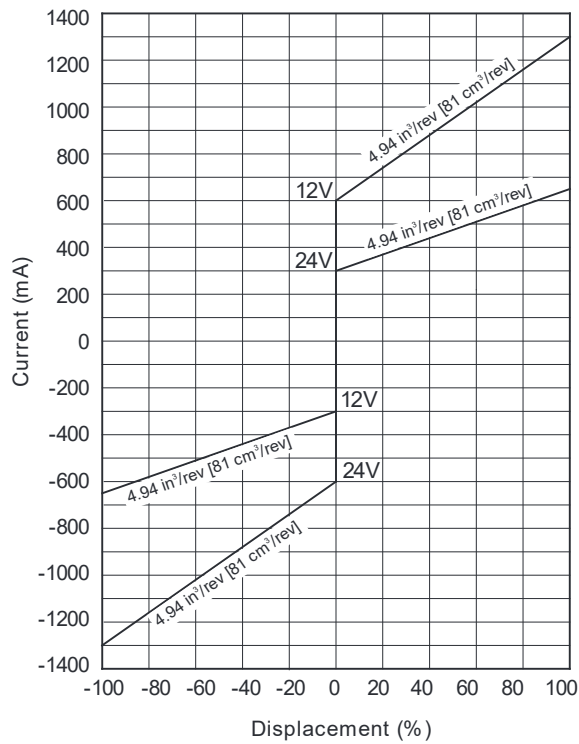


C055 Amperage vs. Displacement

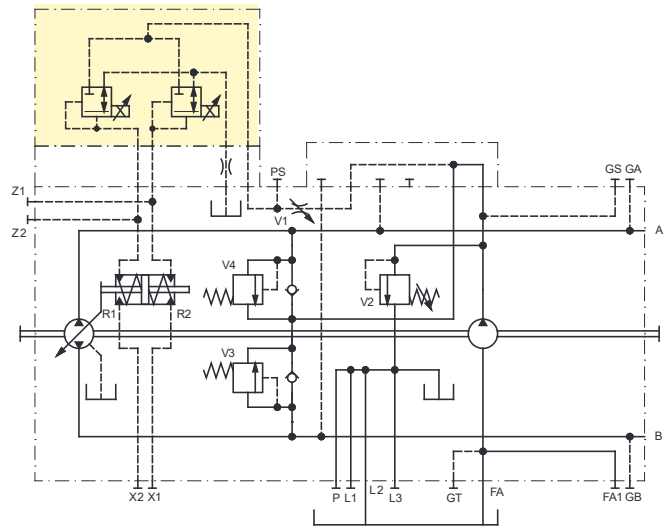


Controls

C081 Amperage vs. Displacement



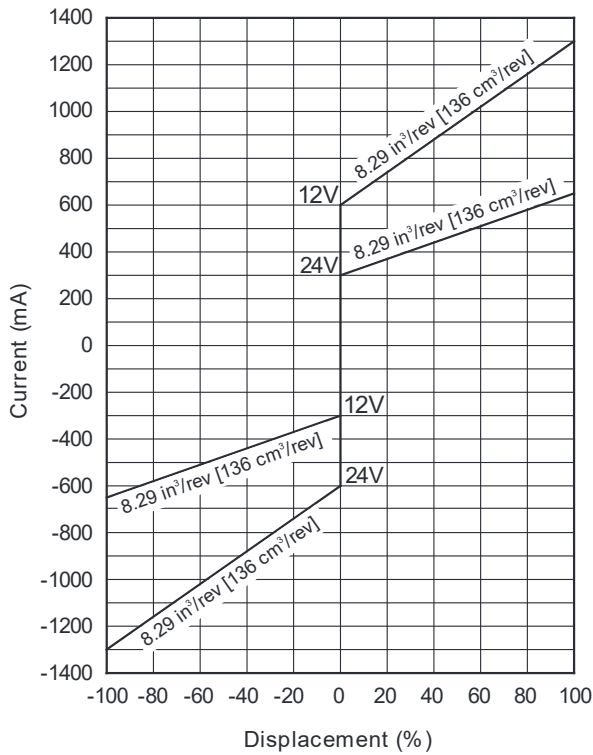
Nominal output shown. Actual output will vary depending on input speed and system pressures.



Solenoid 24V: Current min. 300 mA max 650 mA
 Solenoid 12V: Current min. 600 mA max 1300 mA
 PWM frequency: 110 Hz

Controls

C136 Amperage vs. Displacement



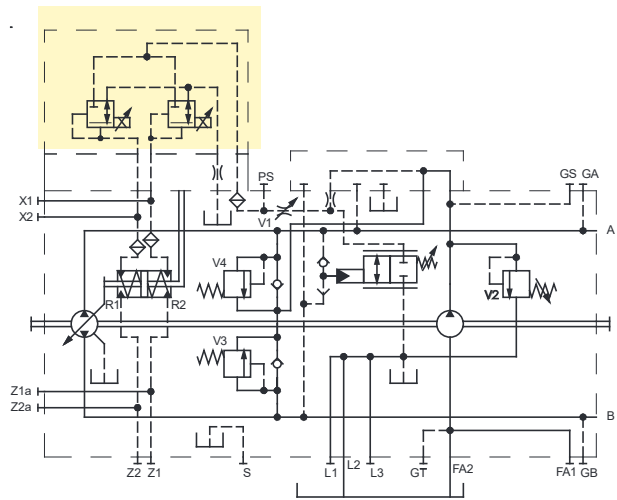
Nominal output shown. Actual output will vary depending on input speed and system pressures.

NOTE:

The tolerance on control coil amperage is $\pm 10\%$ of maximum value.

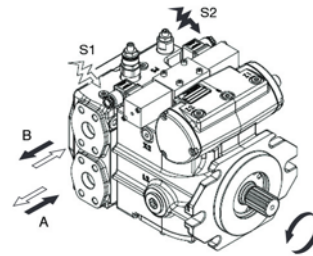
WARNING:

Use of the G control can require a review of the engine and vehicle parameters to ensure that the pump is set up correctly. We recommend that applications be reviewed by a Parker technician.

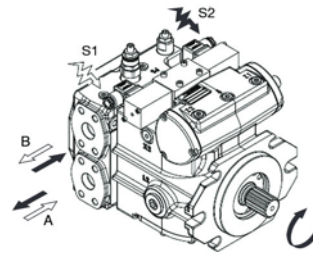


Solenoid 24V: Current min. 300 mA max 650 mA
Solenoid 12V: Current min. 600 mA max 1300 mA
PWM frequency: 110 Hz

Direction of Rotation



L (CCW) Rotation



R (CW) Rotation

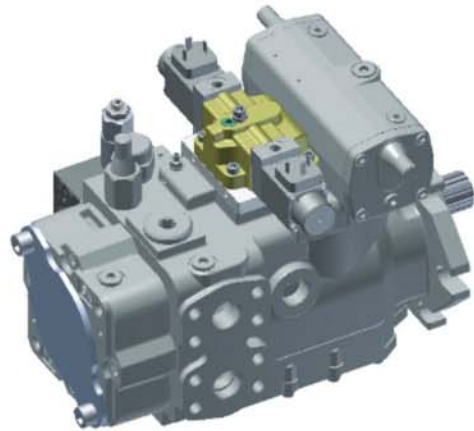
Correlation between direction of rotation (shaft view) control and direction of flow.

Controls

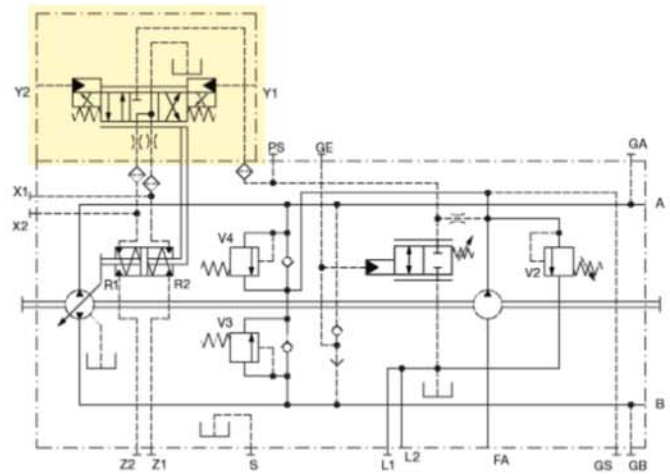
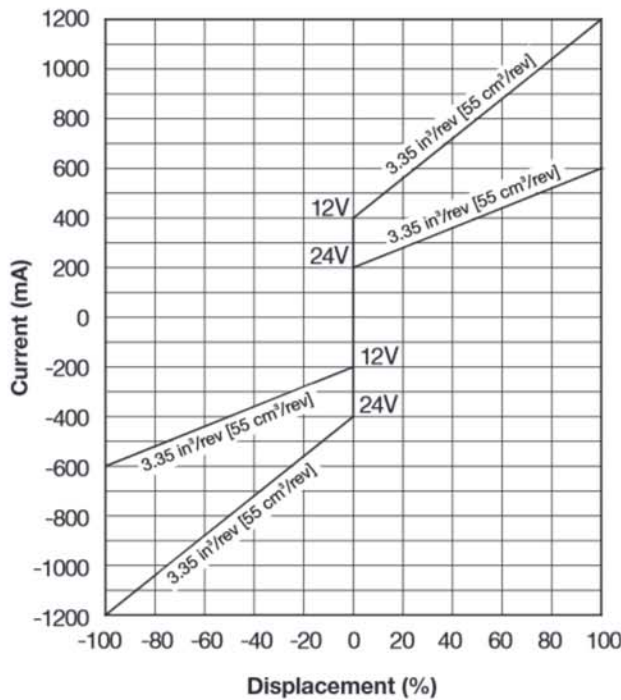
Electric Proportional Control With Hydraulic Override – H

This control has the same electric proportional features as the F control, as well as emergency hydraulic proportional control capability for pilot pressure on Y1 and Y2 ports. The input current of the two proportional solenoids must be controlled by an external amplifier card. The Parker IQAN family of controls is suggested for use.

Hydraulic operation of the H control is designed to be an emergency device to control displacement of the pump in case of a breakdown of the electric circuit it is not intended as the primary control of pump displacement. A pilot pressure of 22 bar (319 psi) is required to swivel the pump to maximum displacement in emergency operation.

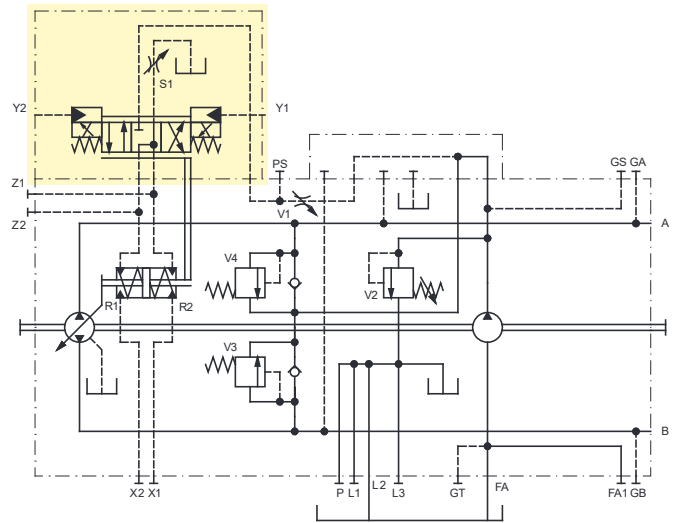
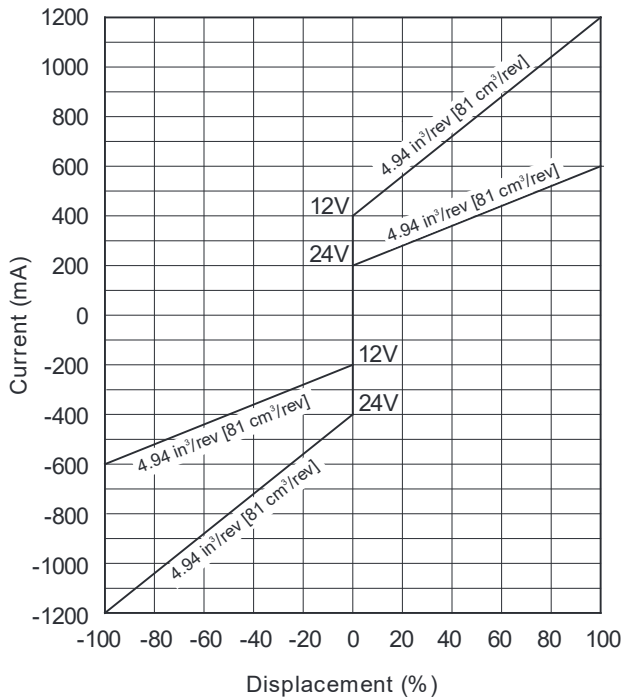


C055 Amperage vs. Displacement

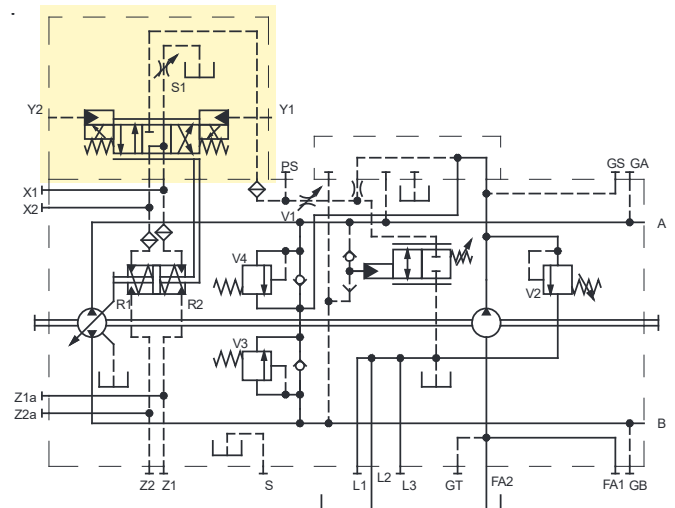
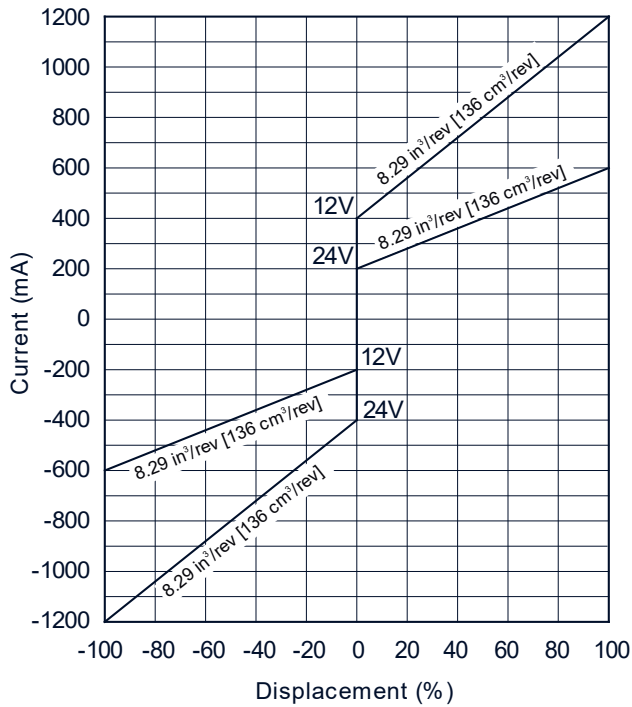


Controls

C081 Amperage vs. Displacement



C136 Amperage vs. Displacement



Controls

C055 and C081 Step Response Chart					
Orifice size	0.6 mm	0.7 mm	0.8* mm	1.2 mm	None
0 to full flow	5.87	4.48	4.27	3.09	2.88
Full to 0 flow	3.52	2.99	2.56	1.17	0.96

C136 Step Response Chart					
Orifice size	0.6 mm	0.7 mm	0.8* mm	1.2 mm	None
0 to full flow	8.22	6.40	5.44	3.63	3.20
Full to 0 flow	4.69	3.63	2.88	1.60	1.07

Time in seconds
 *Standard orifice
 Fluid viscosity = 50 cSt
 Input speed = 1500
 250 bar (3600 PSI) working pressure
 22 bar (320 PSI) charge pressure

NOTE:

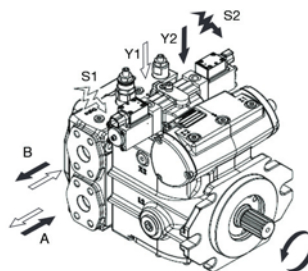
The tolerance on control coil amperage is ± 10% of maximum value.

The spring return feature in the control unit is not a safety device. Internal contamination (contaminated hydraulic fluid, abrasion or residual contamination from system components) can cause the spool valve inside the control unit to get stuck in an undefined position. As a result, the axial piston unit will no longer supply the specified flow. Check which remedial measures should taken on your machine in order to bring the driver consumer into a safe position (e.g. immediate stop).

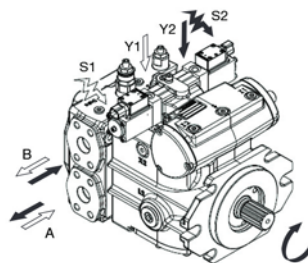
WARNING:

Y1 and Y2 ports must not have any back pressure during normal electric control operation (vented to tank).

Direction of Rotation



L (CCW) Rotation



R (CW) Rotation

Correlation between direction of rotation (shaft view) control and direction of flow.

Automotive – J/K

The automotive control is primarily used in propel applications where a transmission needs to act similar to automotive vehicles with automatic transmissions where an operator selects direction of travel and then controls the prime mover rpm to control vehicle travel speed.

Output flow direction is determined by a directional control valve command either an electrical (J) or hydraulic (K) signal. Pump displacement is controlled by an internal pilot signal which will increase or decrease depending on input RPM and generate output flow into the circuit in the direction commanded by the directional control valve.

System flow will be affected by increases or decreases in system pressure in addition to any change in input RPM.

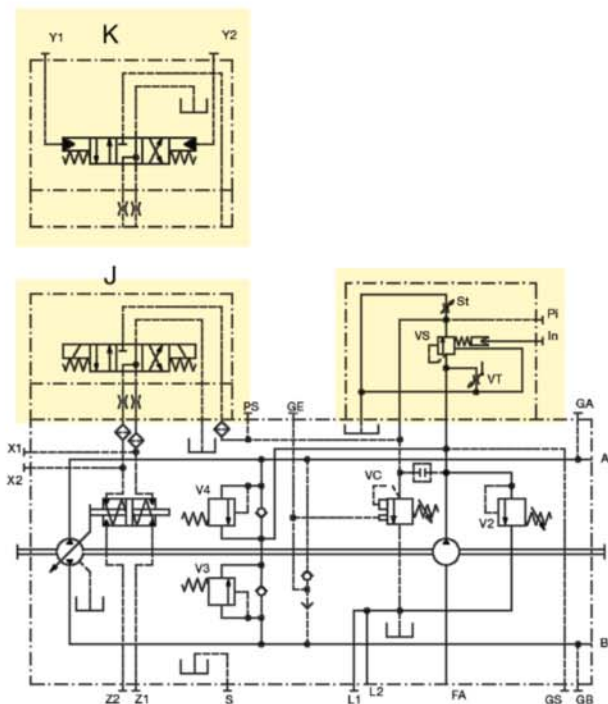
Control is also available with a hydraulic inching valve which will act to keep the pump from producing flow when the inching valve is activated. This valve will allow for high engine speeds and ensure that the pump does not produce any system flow if an auxiliary function requires more input speed. Minimum Pressure for the inching valve to function is 12 bar (175 PSI).

Units with this control also have the option for having a flushing valve mounted onto the pump.

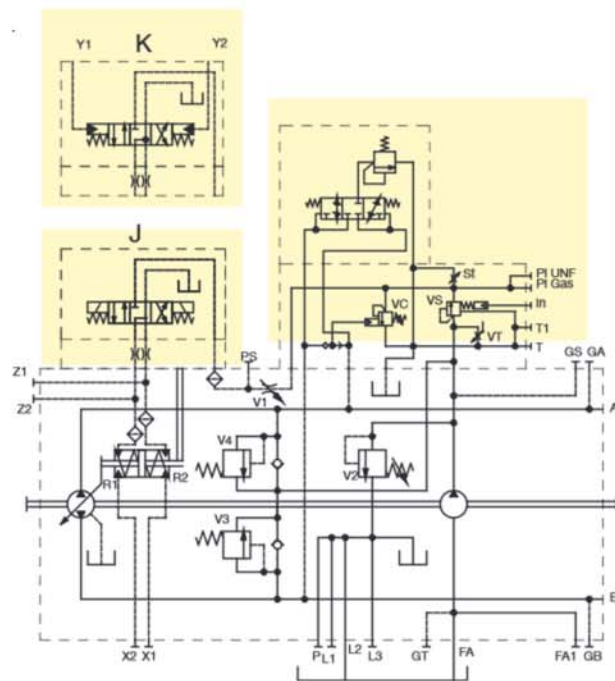
This control is naturally speed and torque sensitive so your Parker representative will need to know more information on the prime mover driving the pump to ensure it is properly applied.



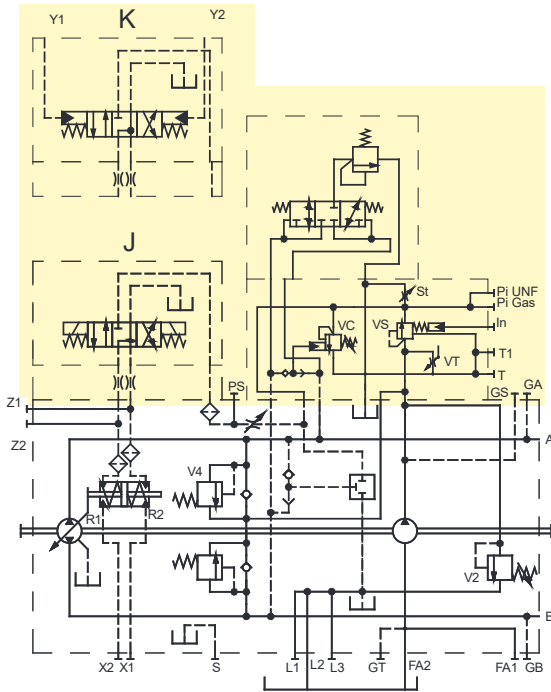
C055 Electric (J) / Hydraulic (K) Automotive With Hydraulic Inching + Flushing Valve



C081 Electric (J) / Hydraulic (K) Automotive With Hydraulic Inching + Flushing Valve



**C136 Electric (J) / Hydraulic (K) Automotive
With Hydraulic Inching + Flushing Valve**



NOTE:

The tolerance on control coil amperage is $\pm 10\%$ of maximum value.

J Coil Information:

30 Watt coils

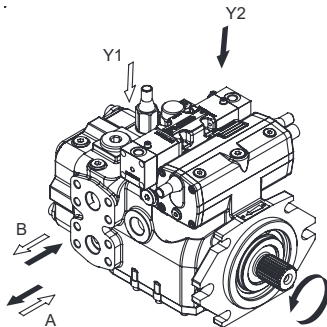
12VDC coil resistance of 4.8 ohms

24 VDC coil resistance of 18.8 ohms

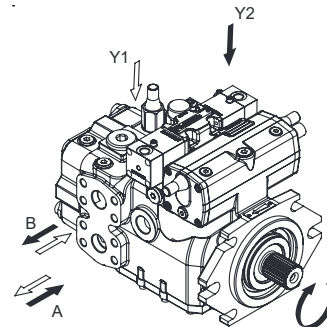
The spring return feature in the control unit is not a safety device. Internal contamination (contaminated hydraulic fluid, abrasion or residual contamination from system components) can cause the spool valve inside the control unit to get stuck in an undefined position. As a result, the axial piston unit will no longer supply the specified flow. Check which remedial measures should taken on your machine in order to bring the driver consumer into a safe position (e.g. immediate stop).

K control requires a pilot pressure of 22 Bar (319 PSI) to shift spool.

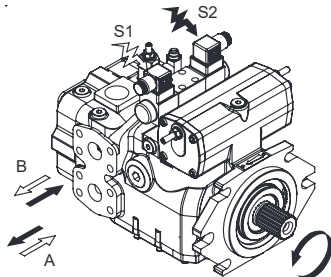
Direction of Rotation (J/K)



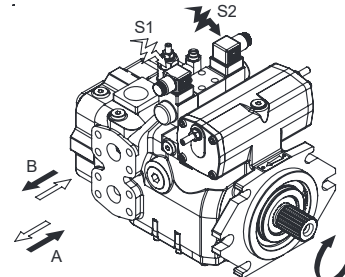
L (CCW) Rotation



R (CW) Rotation



L (CCW) Rotation



R (CW) Rotation

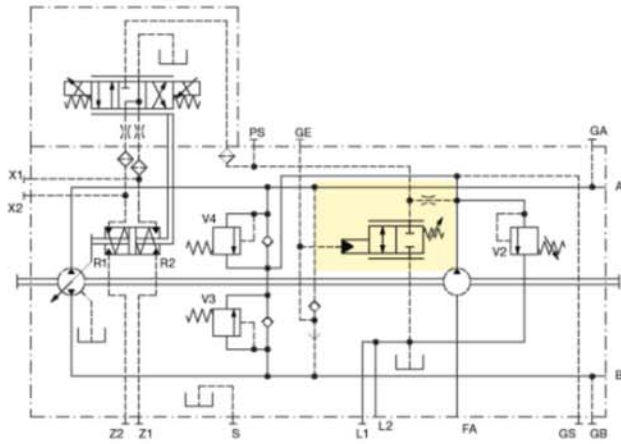
Correlation between direction of rotation (shaft view) control and direction of flow.

Pressure Override – P

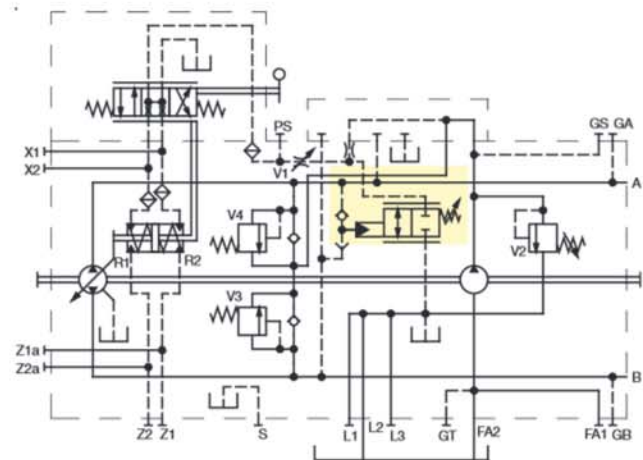
The pressure override valve is designed to avoid opening relief valves. When working pressure reaches the P valve setting, the swash plate swivels back and reduces flow. The valve maintains a constant pressure in the circuit at the setting value. It is advisable to fit the cut-off valve to all systems where pressure peaks

close to the relief valve’s setting, or in hydraulic systems engineered to maximum pump pressure. The pressure override should be set 20 – 30 bar (290 – 435 psi) lower than the cross port relief valve setting. Setting range: 100 – 420 bar (1,450 – 6,090 psi)

C055 With Type P Pressure Override

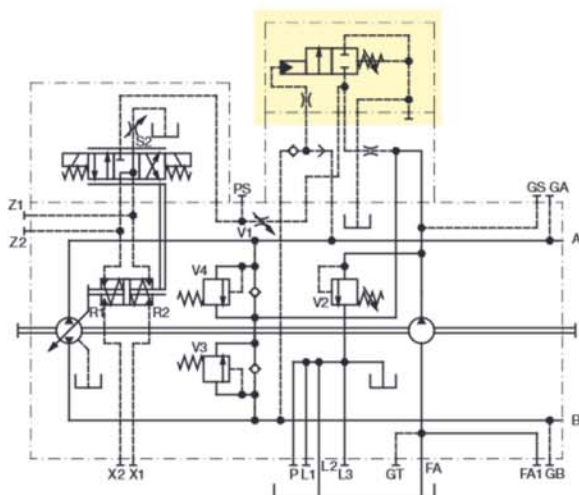


C136 With Type P Pressure Override



Note:
The electric override valve can be assembled on standard C pumps and combined with pressure override valves.

C081 With Type P Pressure Override

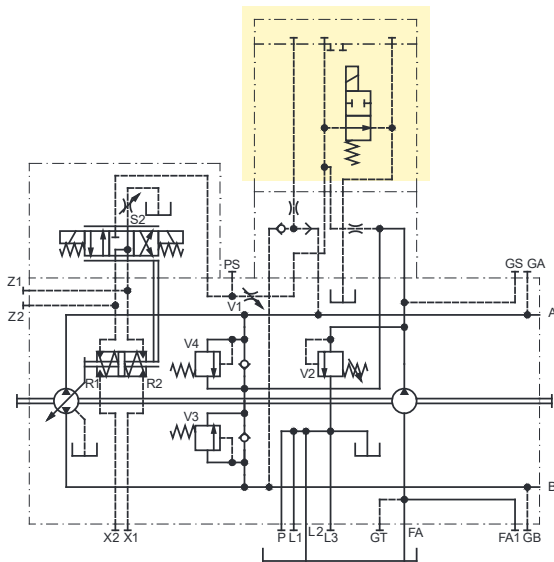


Electric Cut-Off Valve – E

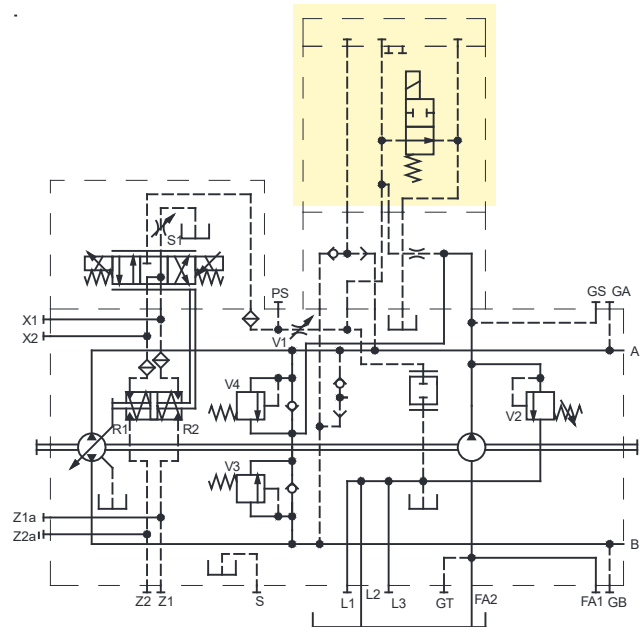
The electric cut-off valve, directly connected to the C pump housing, swivels pump flow back to zero when power supply to the on/off solenoid is cut off.

This valve is designed for applications subject to safety regulations, which require stopping the machine in case of no electric signal. Feed voltage is 24V d.c. (optional 12V d.c.).

C081 With Type E Override



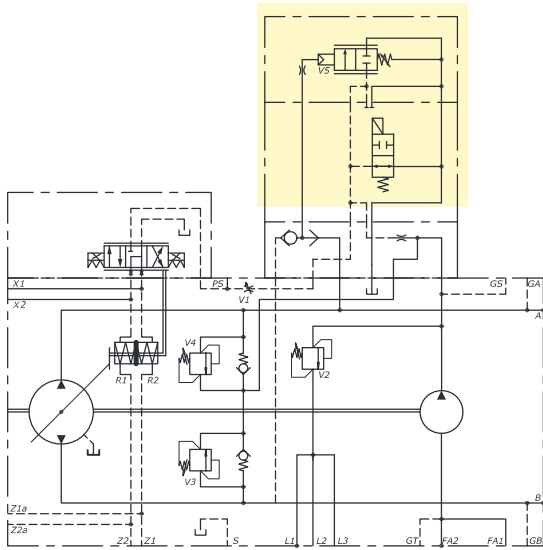
C136 With Type E Override



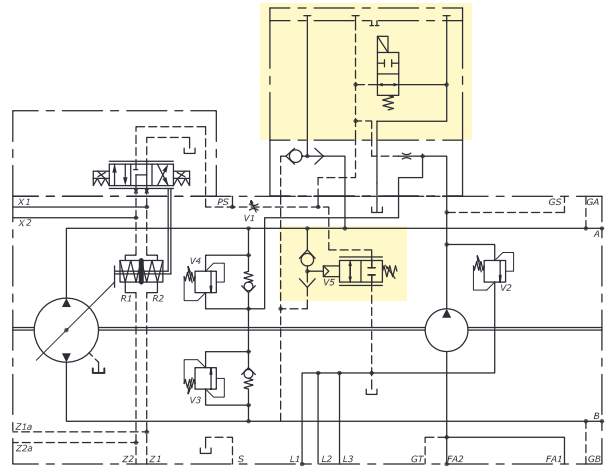
Electrical Cut-Off Valve and Pressure

The C option override is a combination of the P and E override options. P and E override option details for operation information.

C081 With Type C Override



C136 With Type C Override

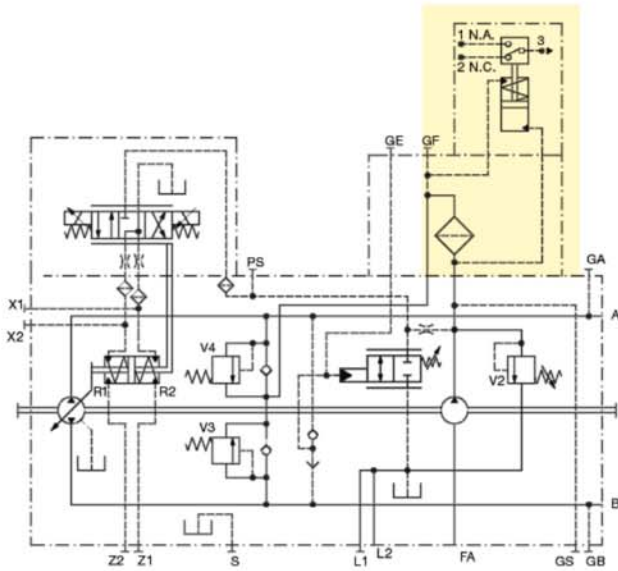


Charge Filtration Options

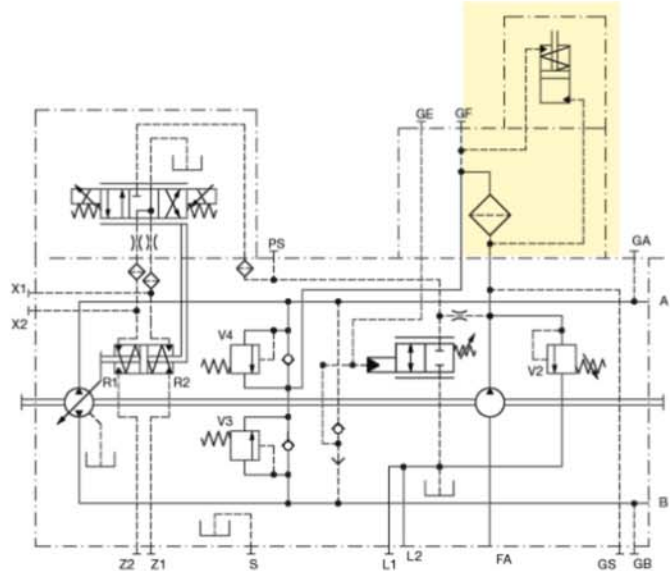
To guarantee an optimum fluid contamination level in the closed loop, the C pump can be equipped with a filter. It is positioned on the delivery outlet of the charge pump. The filter contains a composite-fiber

filtering element. Electrical (connector DIN 43650) and mechanical filter clogging sensors (standard 8 bar/116 psi) are available. It's possible to combine the filter with cut-off valves.

C055 With Charge Filter Option

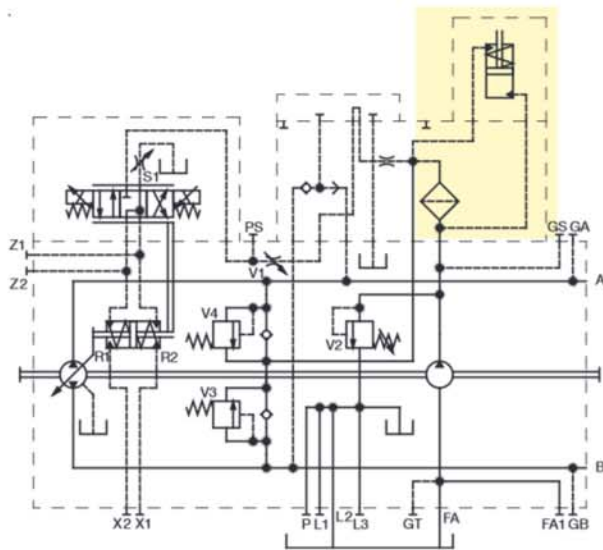


Mechanical Sensor

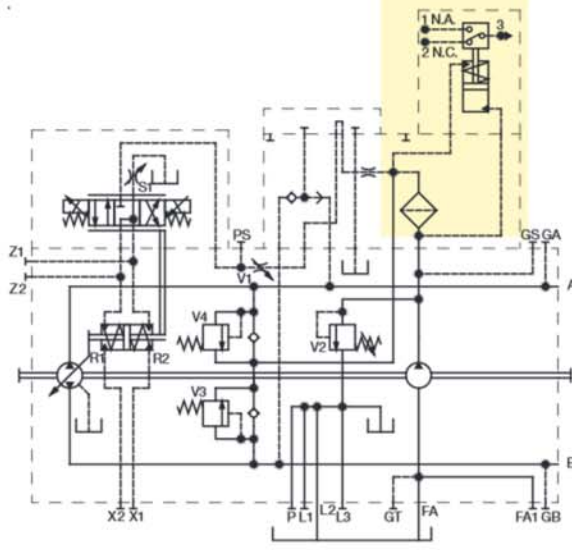


Electrical Sensor

C081 With Charge Filter Option

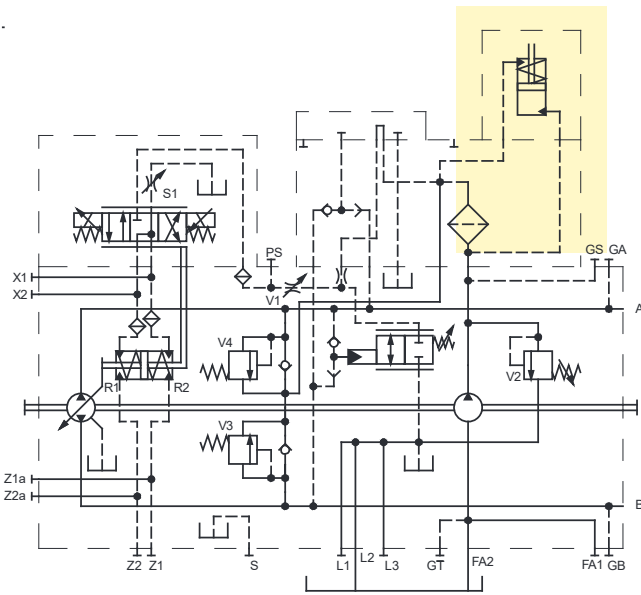


Mechanical Sensor

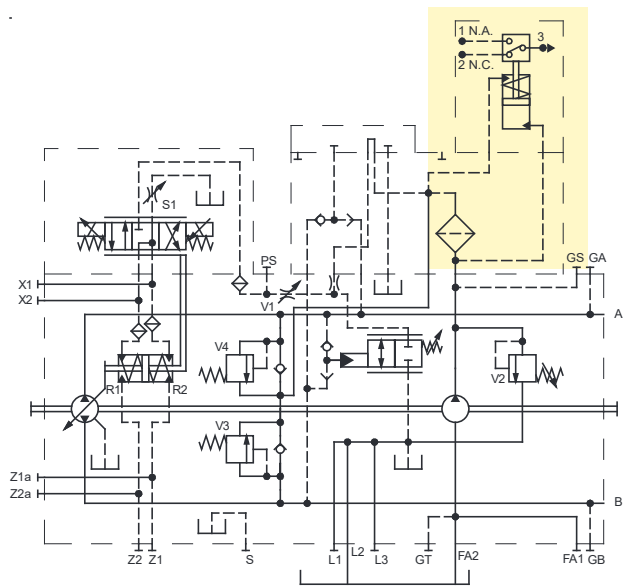


Electrical Sensor

C136 With Charge Filter Option



Mechanical Sensor



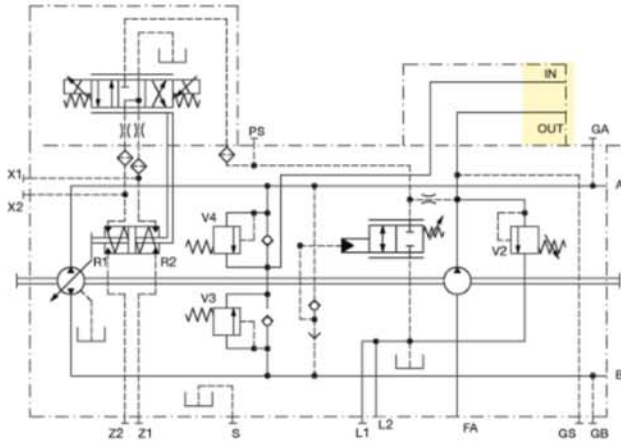
Electrical Sensor

SPDT	Max Resistive Load	Max Inductive Load
C.A.\ A.C. 125-250 V	1 A	1 A
C.C.\ D.C. 30 V	2 A	2 A
C.C.\ D.C. 50 V	0,5 A	0,5 A
C.C.\ D.C. 75 V	0,25 A	0,25 A
C.C.\ D.C. 125 V	0,2 A	0,03 A

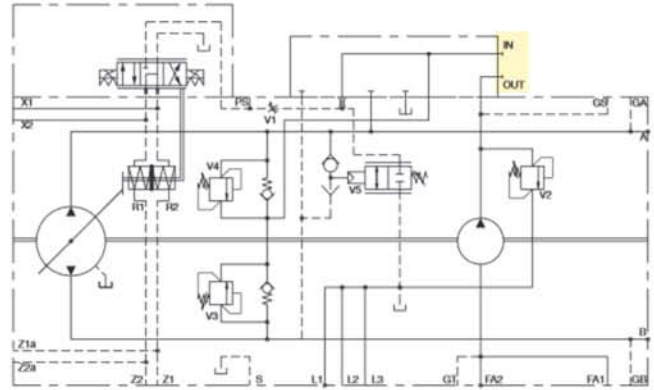
Remote Charge Filtration – R

Valve block supplied on the pumps with ports for connecting a customer supplied remotely mounted hydraulic filter.

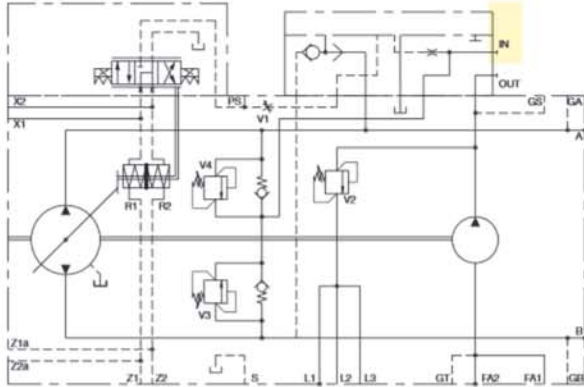
C055 With Remote Charge Filtration



C136 With Remote Charge Filtration



C081 With Remote Charge Filtration

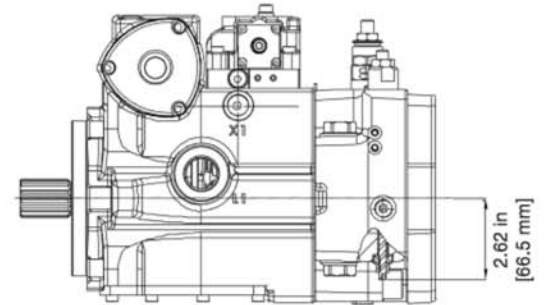
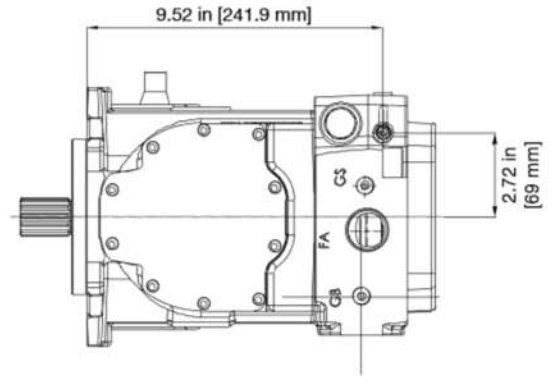
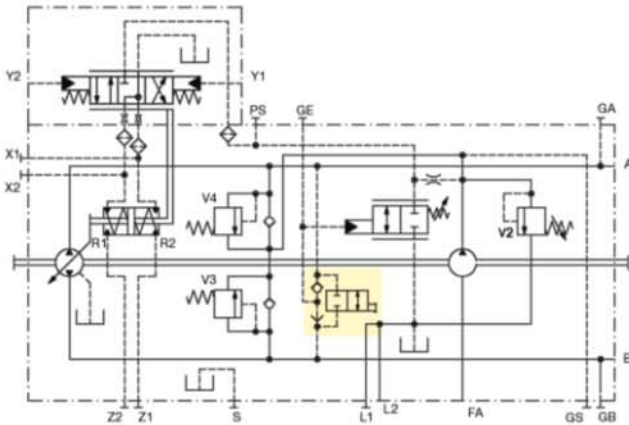


Do not operate units without filter connected to IN and OUT ports

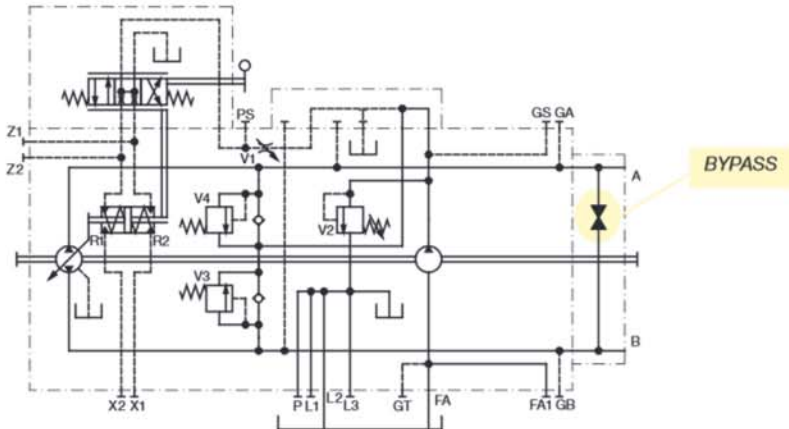
Bypass Valve

The bypass valve allows the connection of pressure port lines A and B. To open the valve, unlock the locking nut and turn the screw six turns counterclockwise. The bypass valve is intended for use at low vehicle speeds. Moving at high speeds may cause damage to transmission components and cause an excess of heat generation.

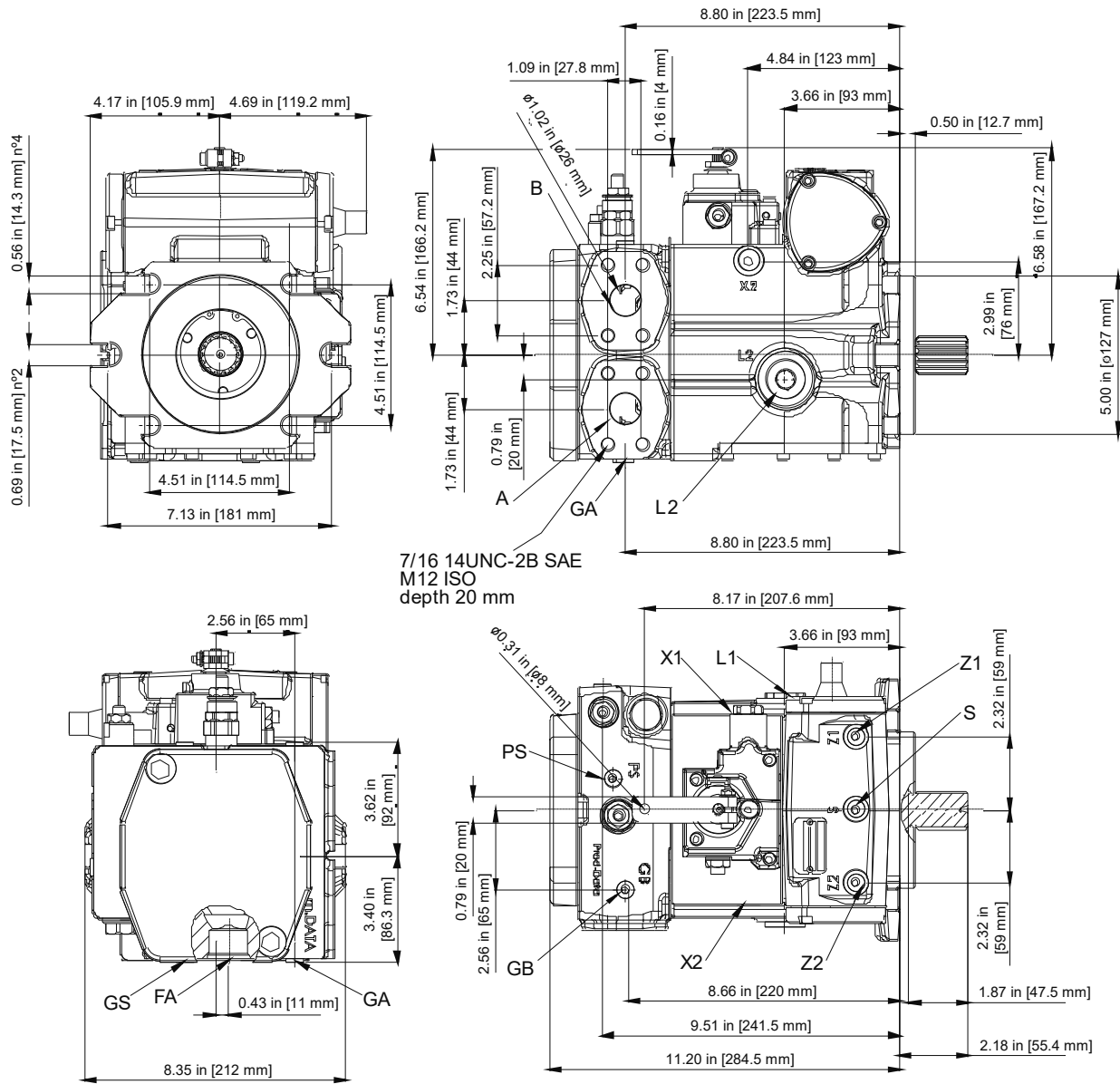
C055



C081



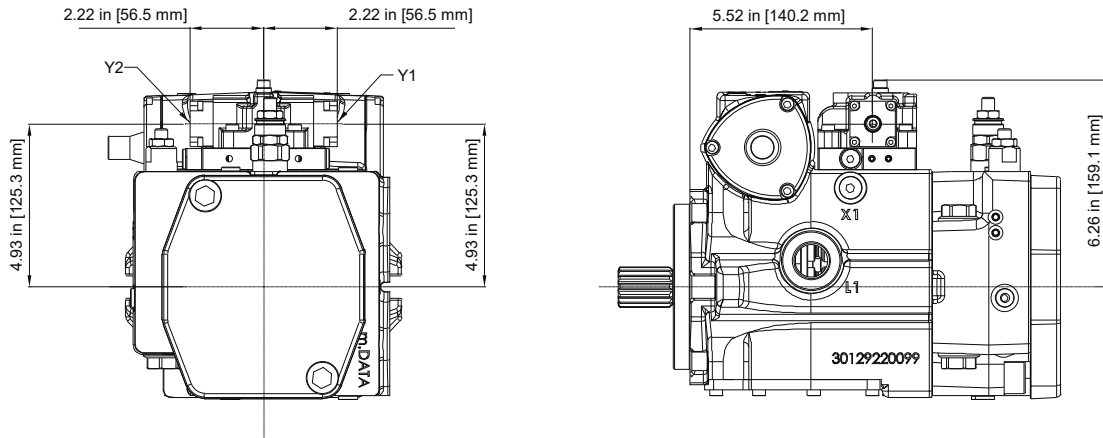
A Control



C055 Port Chart		
Port	Mount C	Mount G
A	1" SAE CODE 62	
B	1" SAE CODE 62	
L1	-12 SAE ORB	3/4" G
L2	-12 SAE ORB	3/4" G
FA	-16 SAE ORB	1" G
GA	-4 SAE ORB	1/4" G
GB	-4 SAE ORB	1/4" G

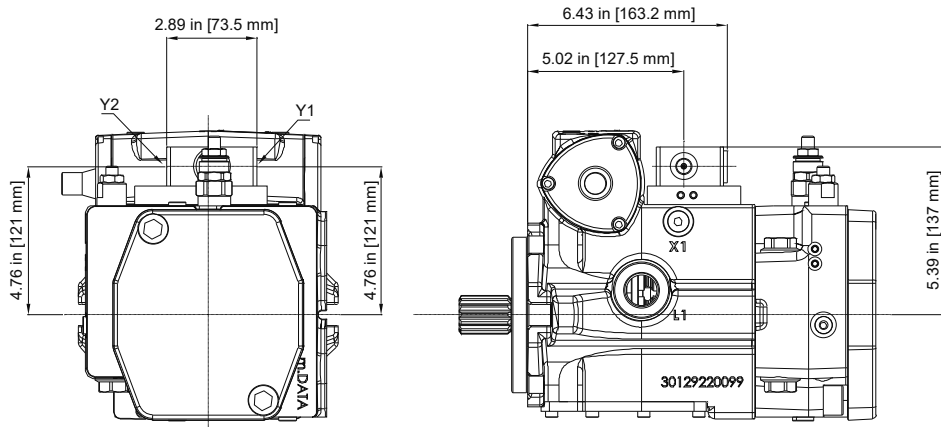
C055 Port Chart		
Port	Mount C	Mount G
GS	-4 SAE ORB	1/4" G
PS	-4 SAE ORB	1/4" G
X1	3/8" G	3/8" G
X2	3/8" G	3/8" G
Z1	1/8" G	1/8" G
Z2	1/8" G	1/8" G
S	-4 SAE ORB	1/4" G

C Control



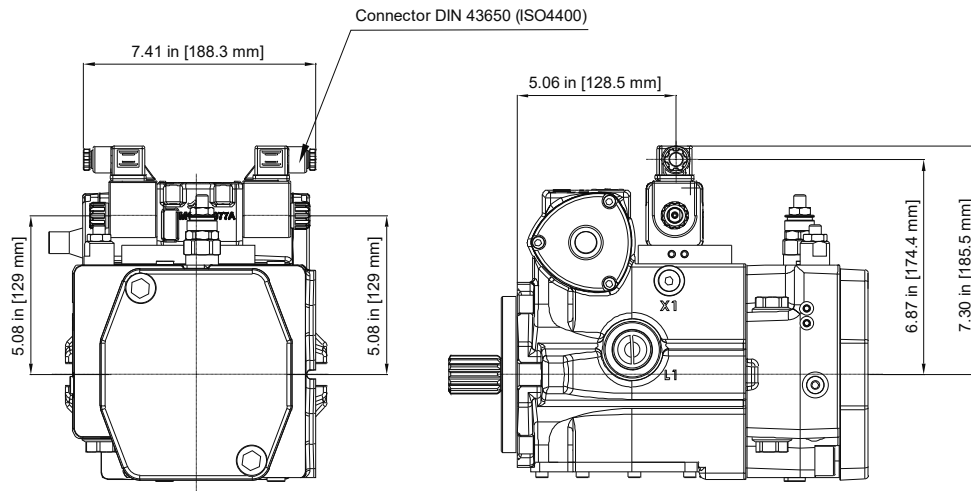
Y1-Y2: Control piloting pressure ports – 1/4" G (BSPP) (ISO)
 7/16" – 20 UNF 2B (SAE)

D Control

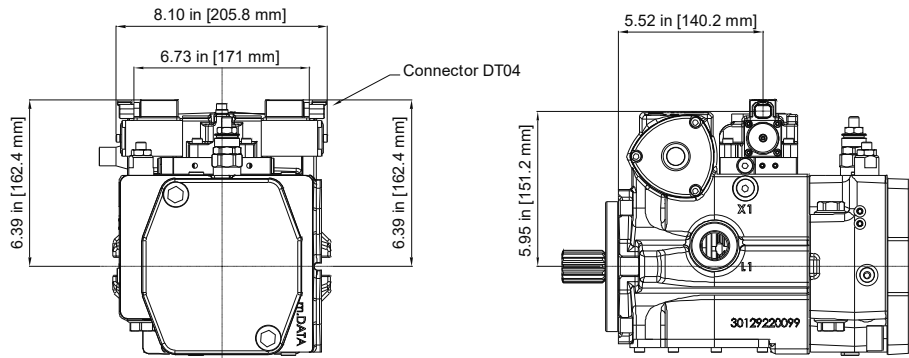


Y1-Y2: Control piloting pressure ports – 1/4" G (BSPP) (ISO)
 7/16" – 20 UNF 2B (SAE)

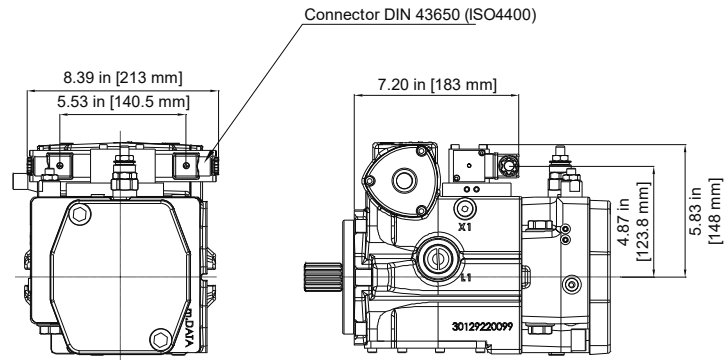
E Control



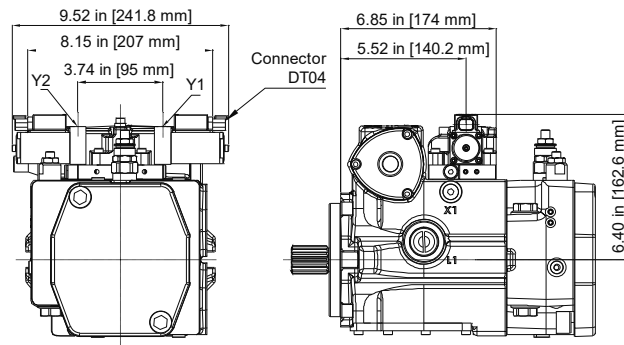
F Control



G Control



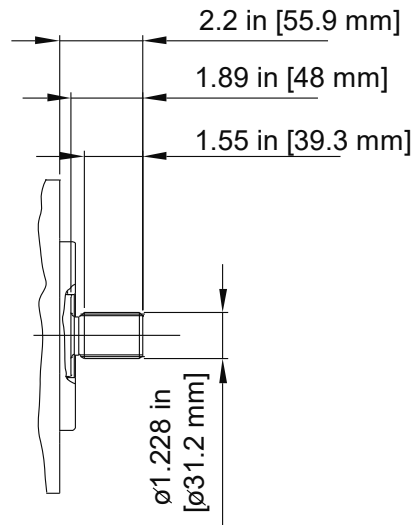
H Control



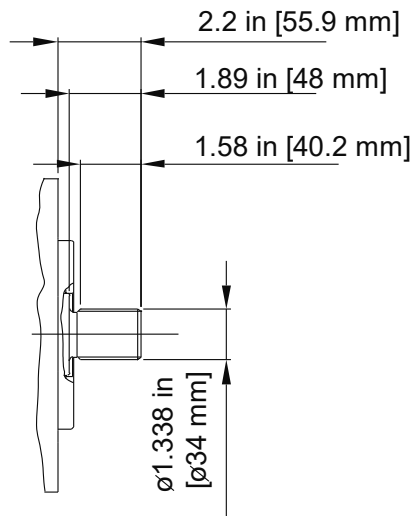
Y1-Y2: Control piloting pressure ports – 1/8" G (BSPP) (ISO)
 5/16" – 24 UNF 2B (SAE)

Shaft

1: Splined SAE 1 - 1/4" 14T 12/24 Dp – Flat Root Class 5 ANSI B92.1a – 1976



2: Splined SAE 1 - 3/8" 21T 16/32 Dp – Flat Root Class 5 ANSI B92.1a – 1976



Through Drives

The C pump can be supplied with a through drive, which can operate in tandem with a second pump. Available flanges include SAE A, SAE B, SAE C, SAE B-B and SAE C-C flanges.

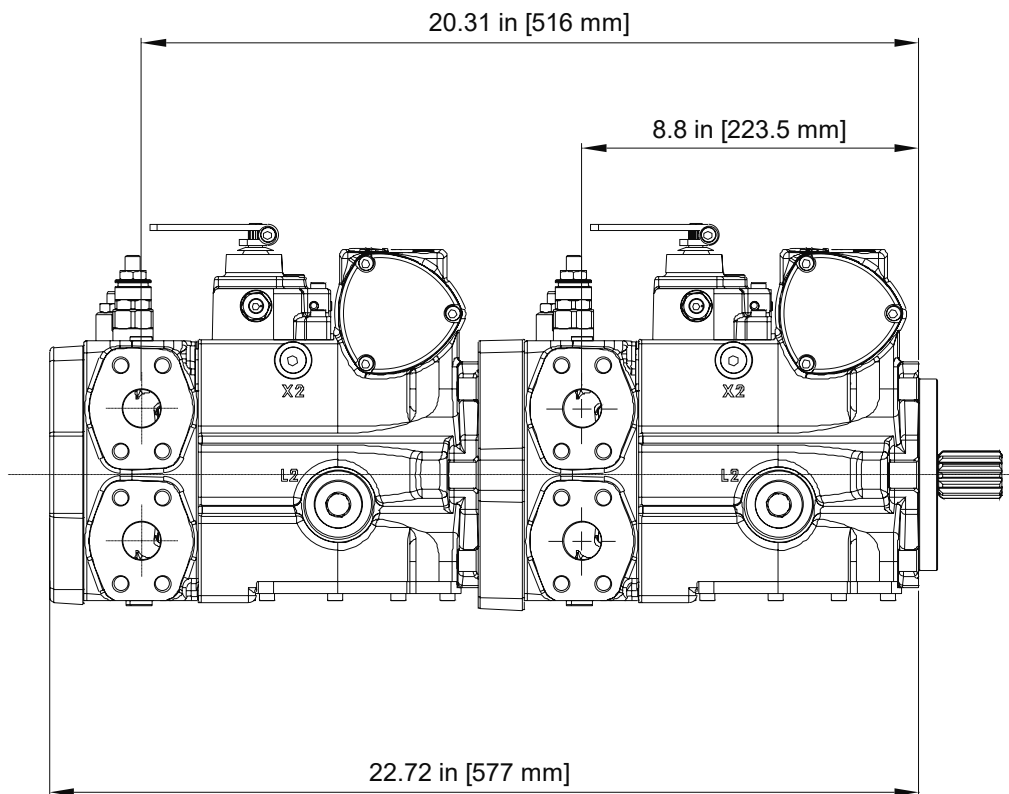
Maximum permissible drive-shaft torques for the first pump, as well as maximum through drive torques are listed in the table below.

WARNING:

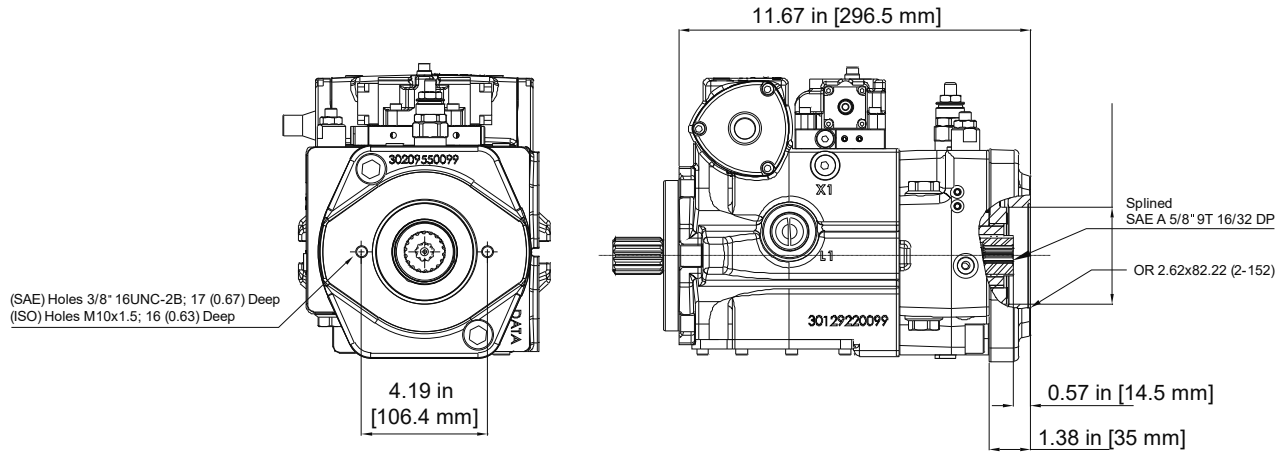
The effective torque value on the shaft of first pump is given by the sum of the torques required from each pump making the system.

Size		055	
Drive shaft		2 Z21 16/32 DP	1 Z14 12/24 DP
Drive shaft max torque	Nm [lbf-ft]	950 (700)	620 (457)
Through drive max torque	Nm [lbf-ft]	665 (490)	620 (457)

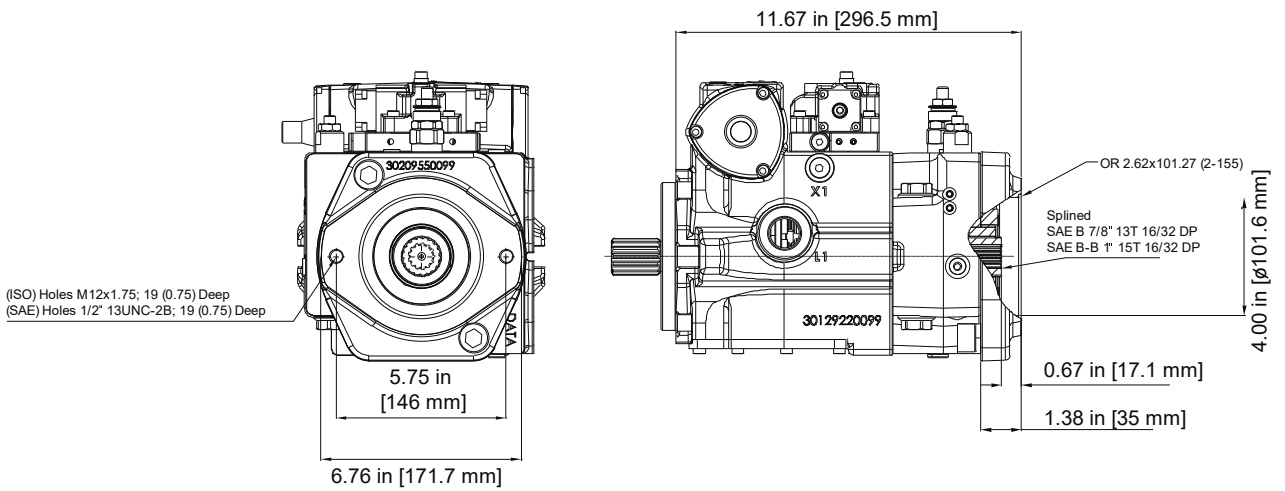
C055 Tandem for Reference



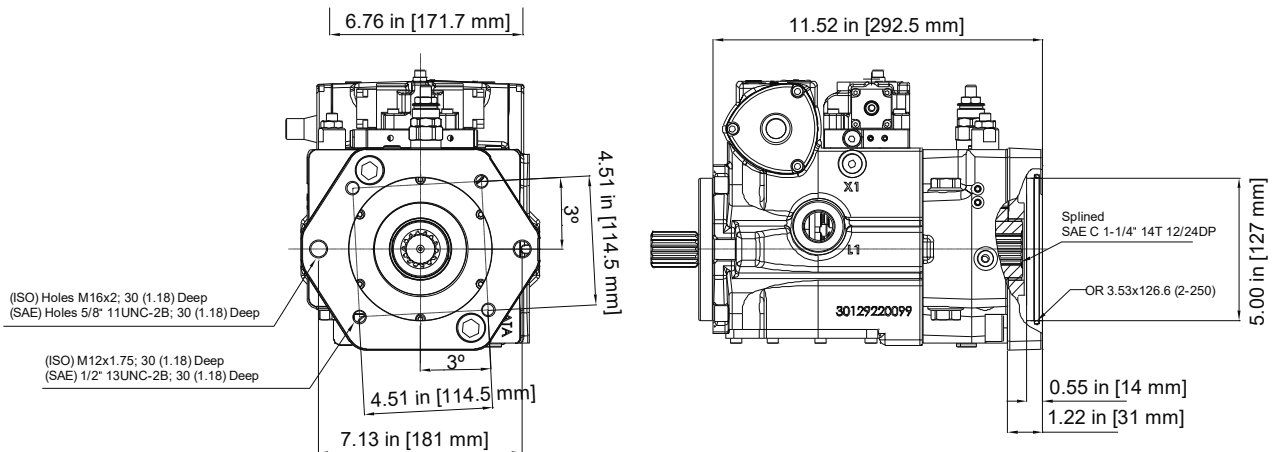
Through Drive Option A



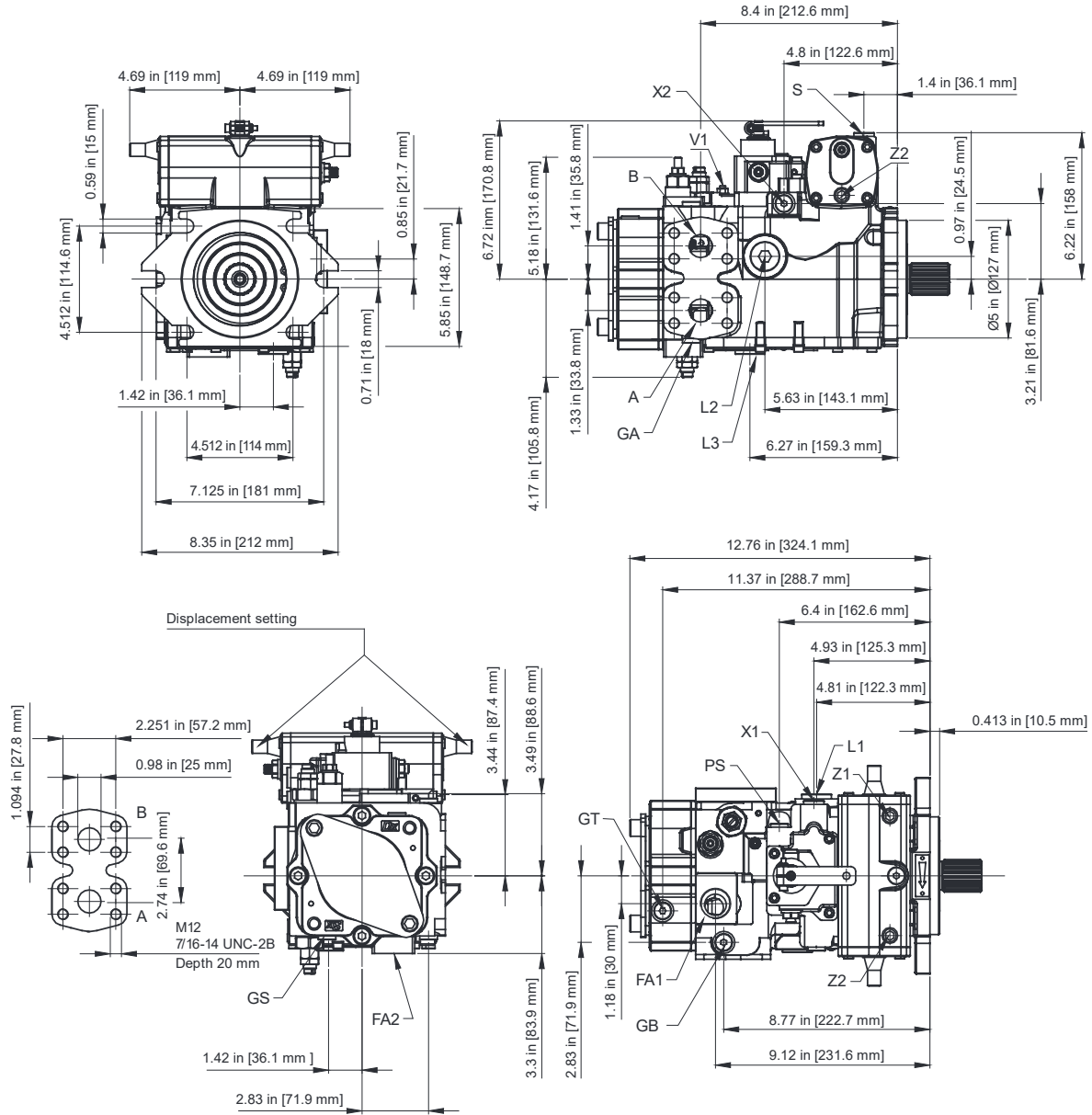
Through Drive Option B



Through Drive Option C



A Control

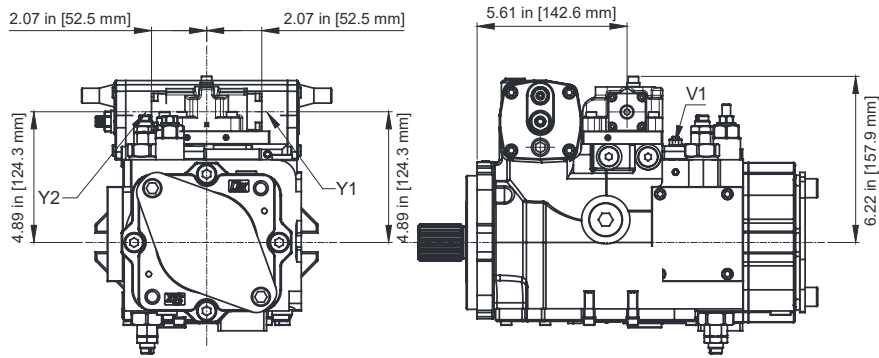


C081 Port Chart		
Port	Mount C	Mount G
A	1" SAE CODE 62	1" SAE CODE 62
B	1" SAE CODE 62	1" SAE CODE 62
L1	-12 SAE ORB	3/4" G
L2	-12 SAE ORB	3/4" G
FA1	-16 SAE ORB	1" G
FA2	-16 SAE ORB	1" G
GA	-4 SAE ORB	1/4" G
GB	-4 SAE ORB	1/4" G
GS	-4 SAE ORB	1/4" G

C081 Port Chart		
Port	Mount C	Mount G
PS	-4 SAE ORB	1/4" G
Z1	-4 SAE ORB	1/8" G
Z2	-4 SAE ORB	1/8" G
X1	3/8" G	3/8" G
X2	3/8" G	3/8" G
Y1	-4 SAE ORB	1/4" G
Y2	-4 SAE ORB	1/4" G
S	-4 SAE ORB	1/4" G
GT	-4 SAE ORB	1/4" G

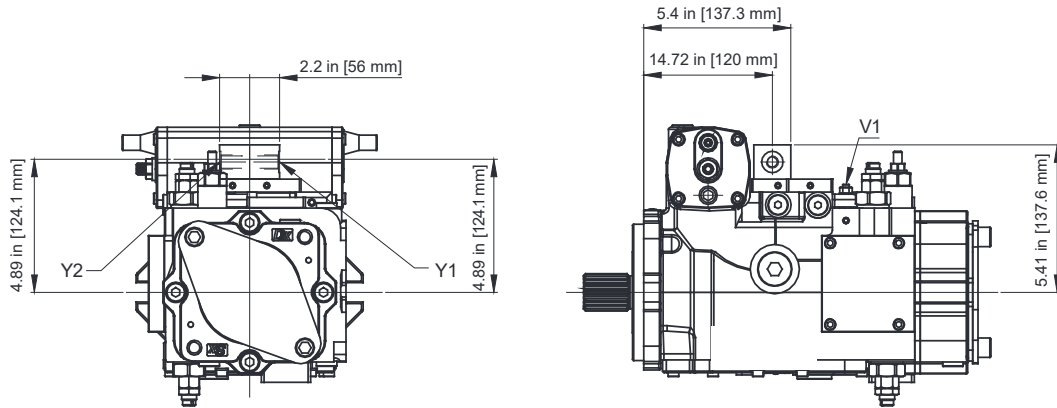


C Control



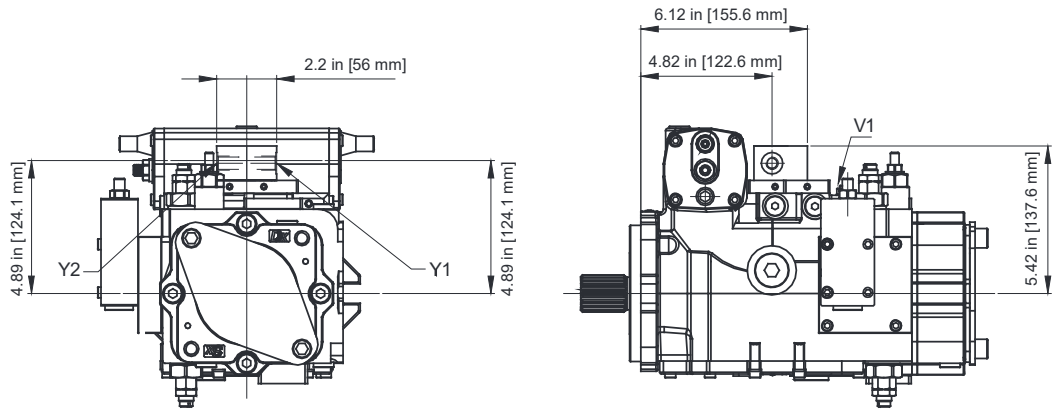
Y1-Y2: Control piloting pressure ports – 1/4 G (BSPP)
 7/16-20 UNF-2B (SAE)
 S1-V1: Adjustable throttle valve

D Control



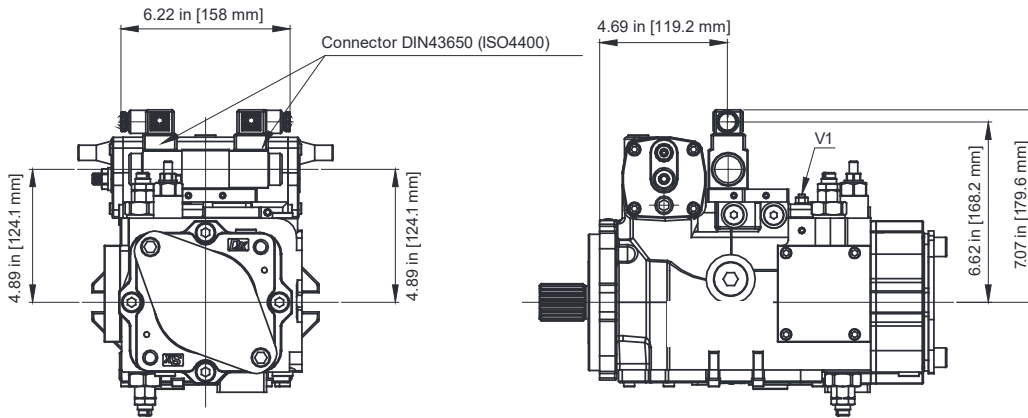
Y1-Y2: Control piloting pressure ports - 1/4 G (BSPP)
 7/16-20 UNF-2B (SAE)
 V1: Adjustable throttle valve

D Control With Cut-Off Valves



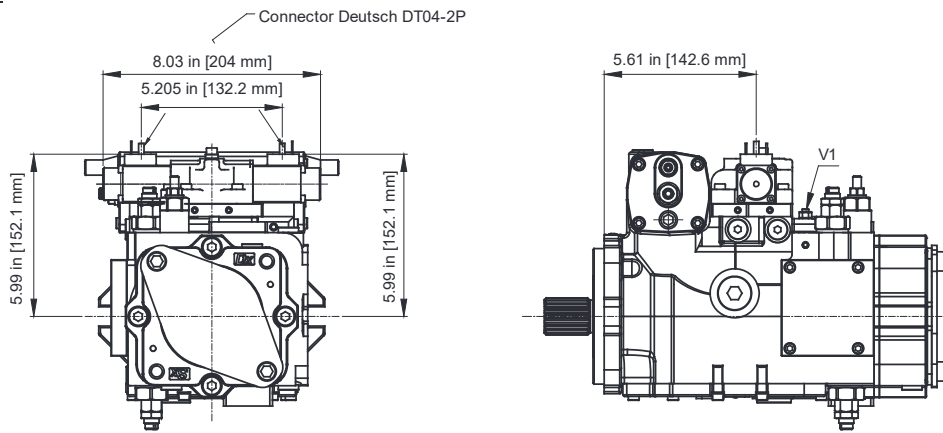
Y1-Y2: Control piloting pressure ports - 1/4 G (BSPP)
 7/16-20 UNF-2B (SAE)
 S1-V1: Adjustable throttle valve

E Control



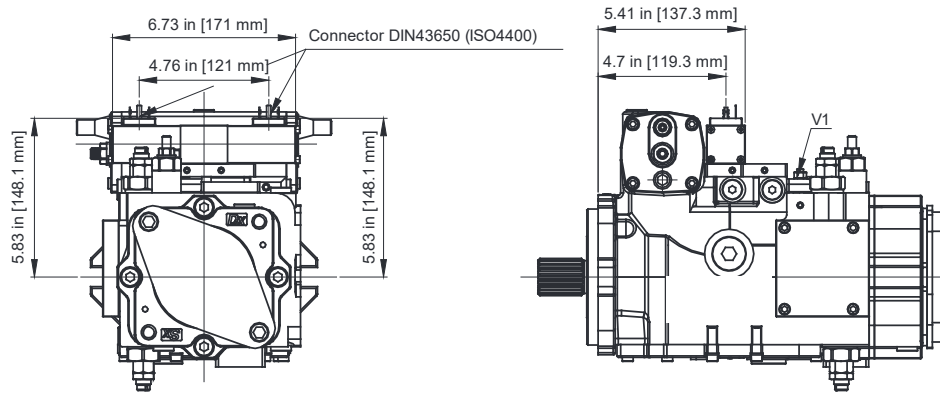
V1: Adjustable throttle valve

F Control



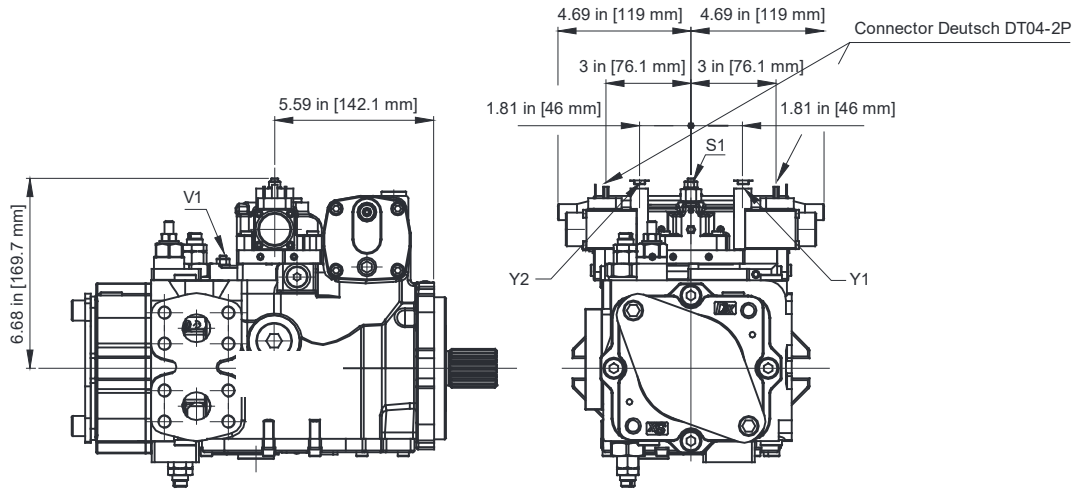
V1: Adjustable throttle valve

G Control



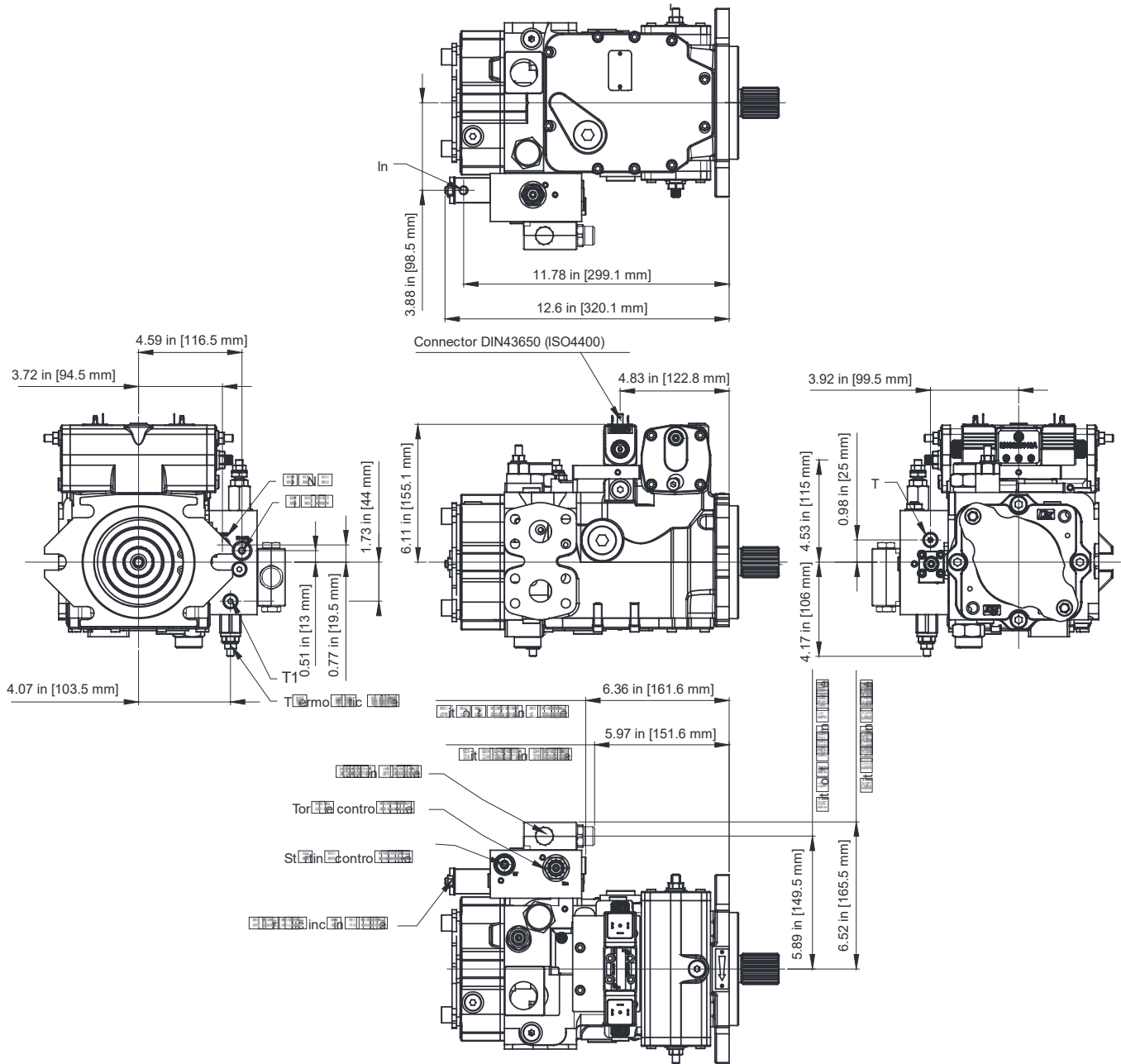
V1: Adjustable throttle valve

H Control

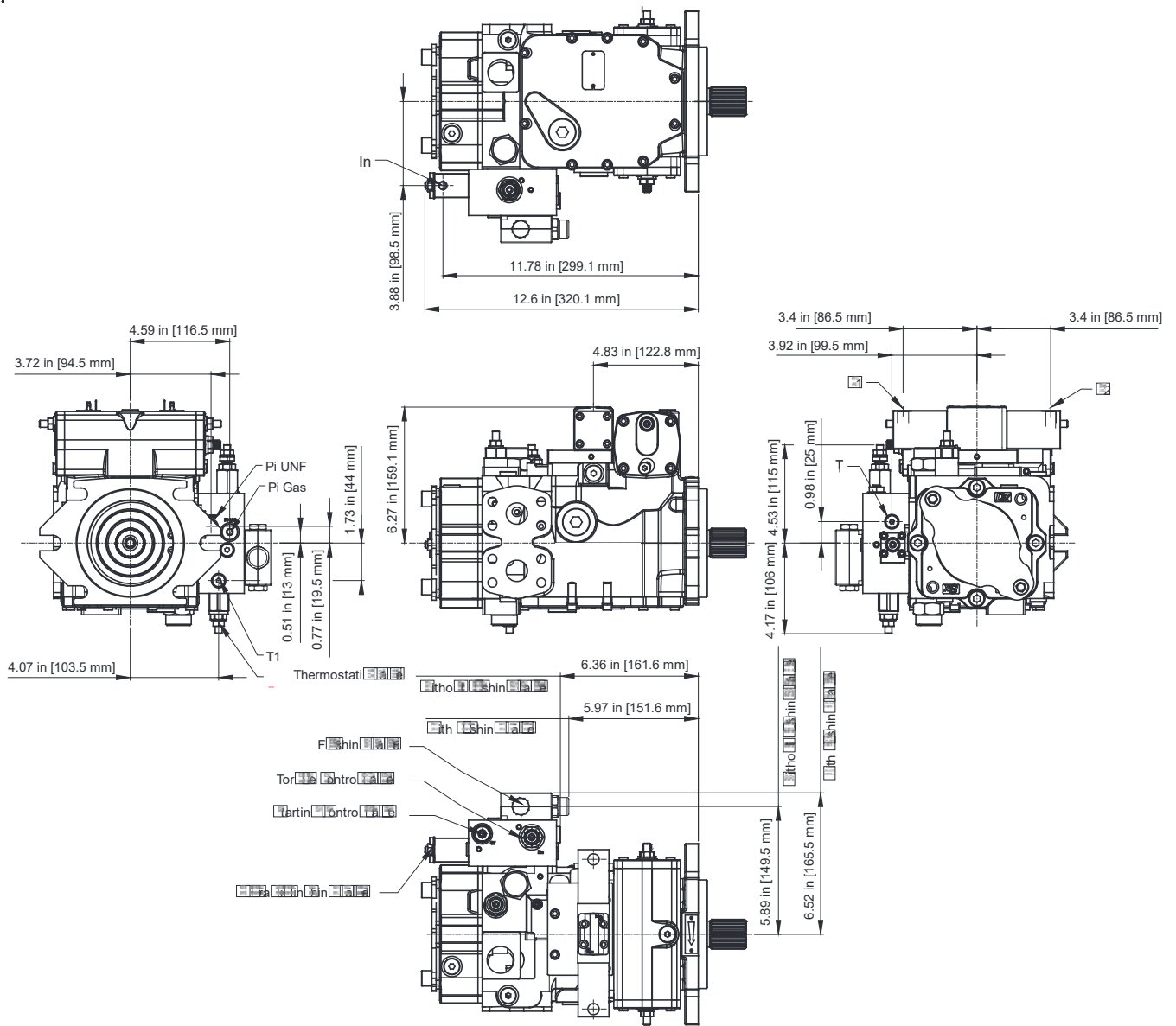


V1: Adjustable throttle valve

Automotive J With Hydraulic Inching



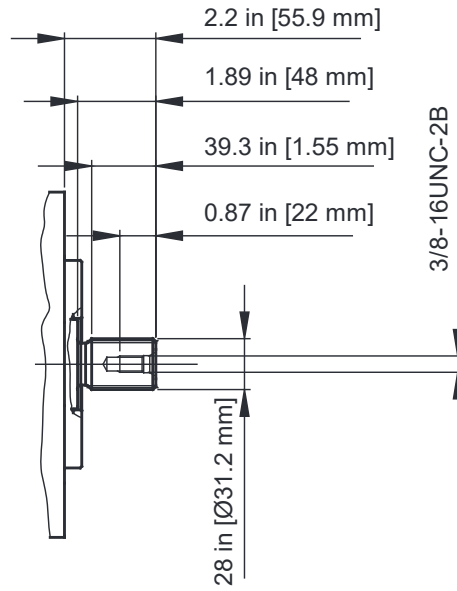
Automotive K With Hydraulic Inching



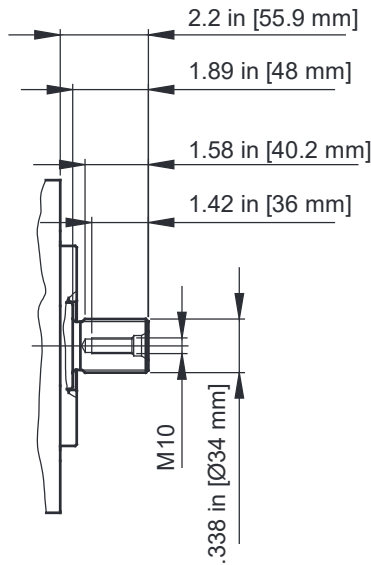
Pi Gas: Piloting pressure gauge port – 1/4 G (BSPP)
 Pi UNF: Piloting pressure gauge port – 7/16" - 20 UNF
 In: Piloting Pressure inching port – 1/8 G (BSPP)
 T1: Drainage Pressure gauge port – 1/8 G (BSPP)
 T: Drainage Pressure gauge port – 1/4 G (BSPP)

Shaft

1: Splined SAE 1 - 1/4" 14T 12/24 Dp – Flat Root Class 5 ANSI B92.1a – 1976

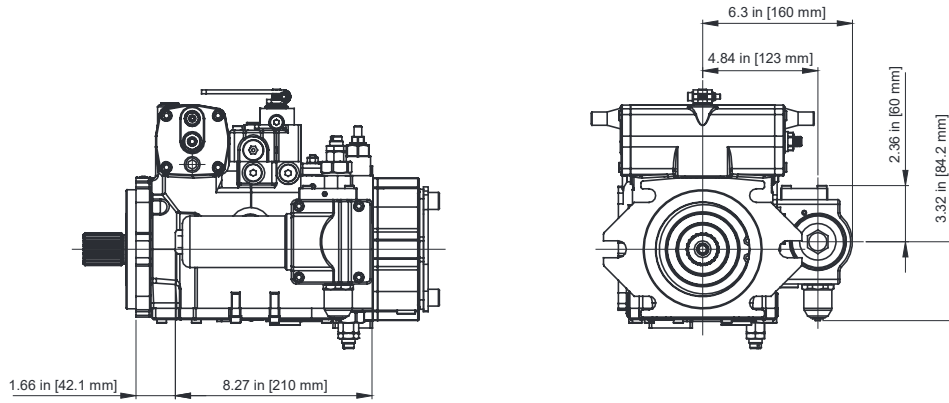


2: Splined SAE 1 - 3/8" 21T 16/32 Dp – Flat Root Class 5 ANSI B92.1a – 1976



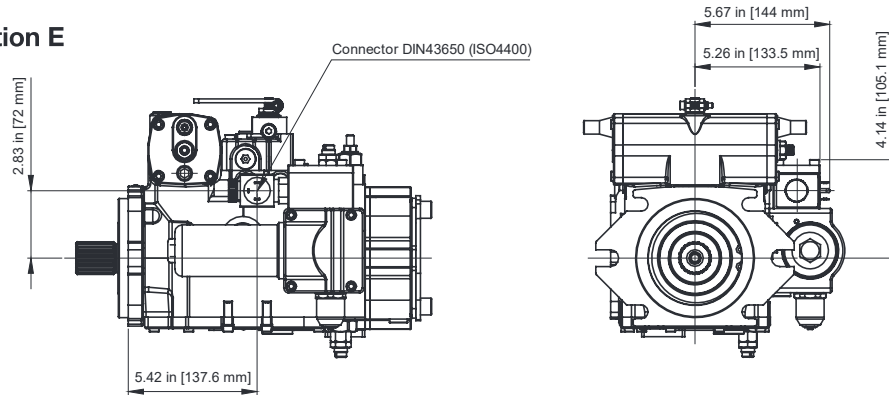
Pump and Accessories

Filter



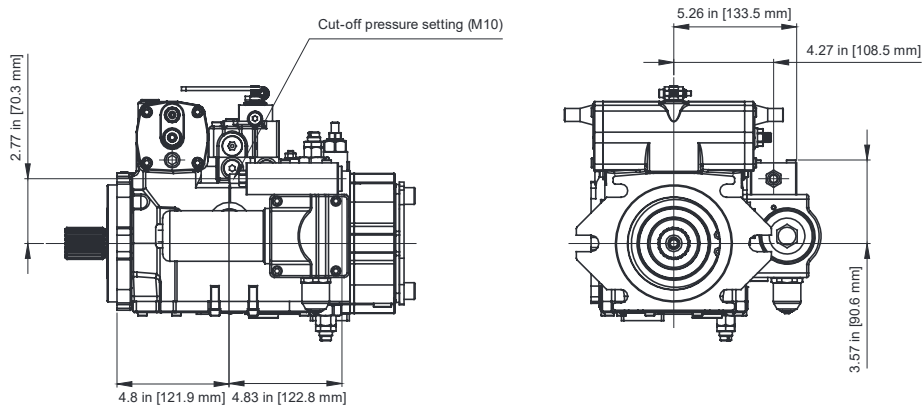
Electric clogging indicator: Connector DIN 43650

Filter and Override Option E



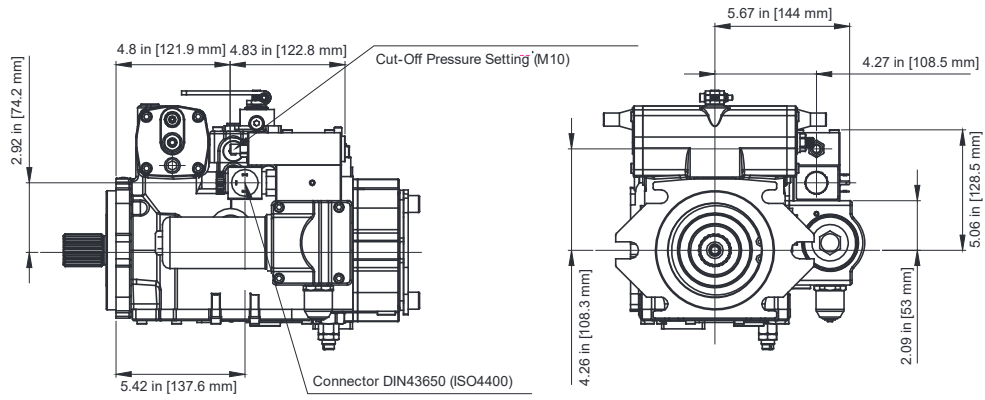
Electric clogging indicator: Connector DIN 43650

Filter and Override Option P



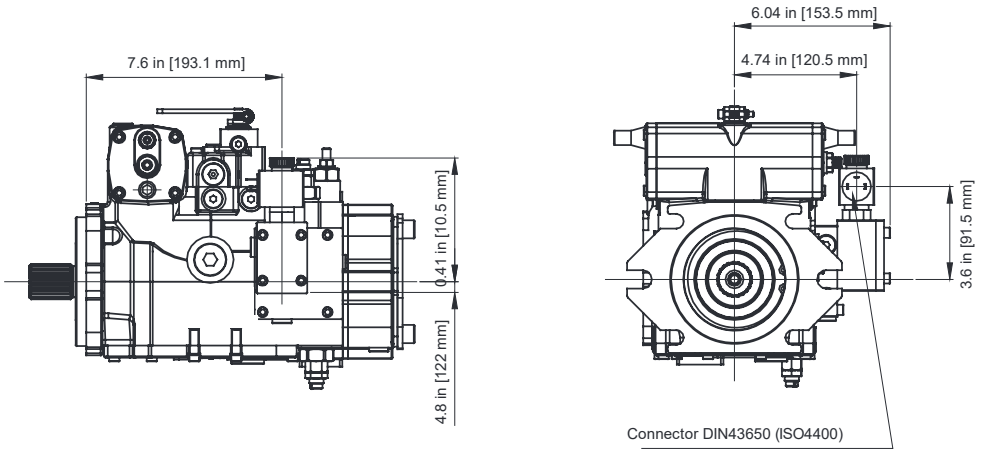
Electric clogging indicator: Connector DIN 43650

Filter and Override Option C

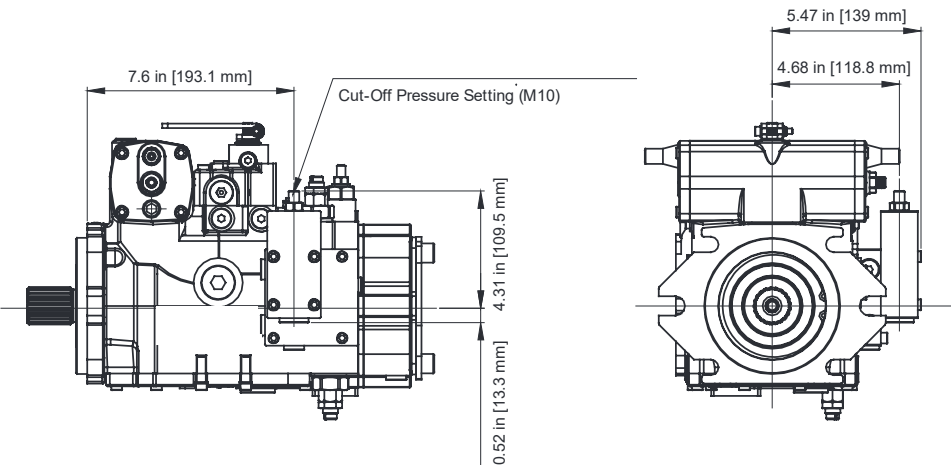


Electric clogging indicator: Connector DIN 43650

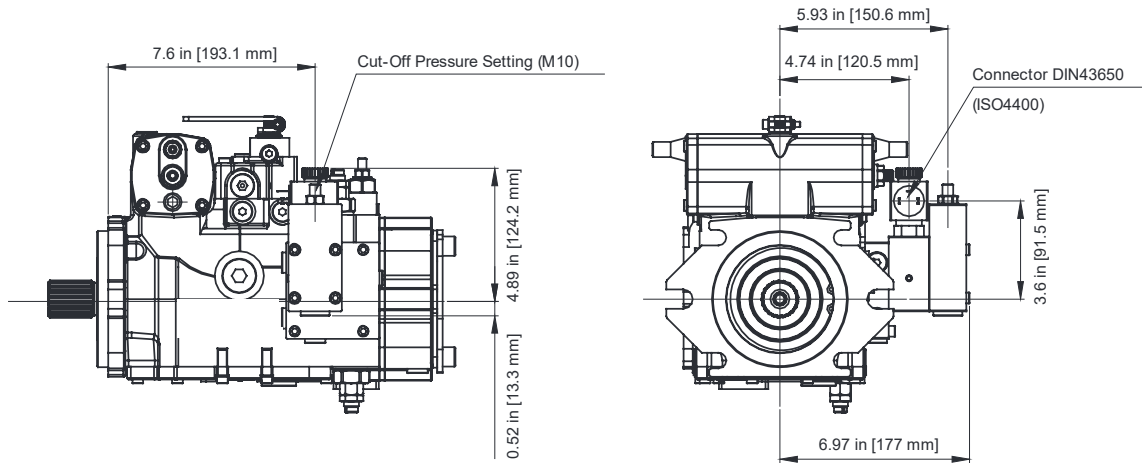
Override Option E



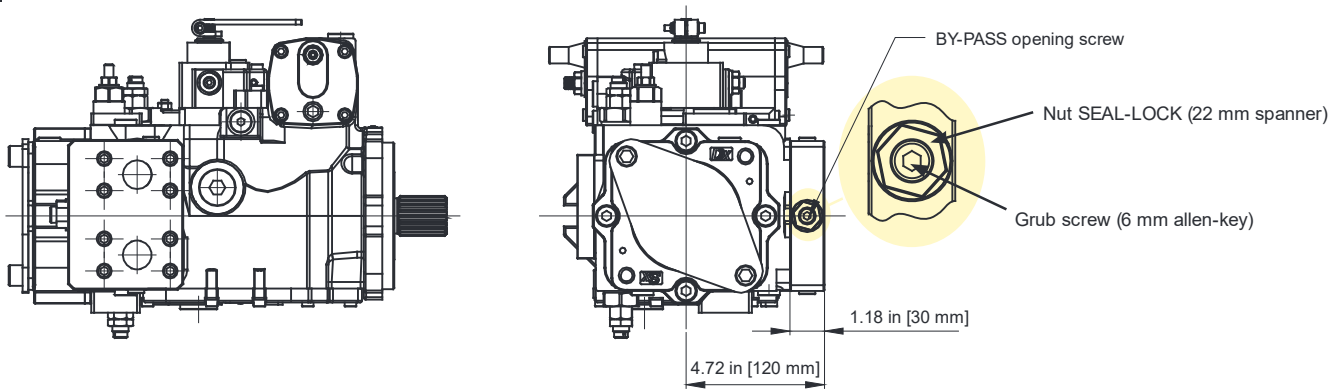
Override Option P



Filter and Override Option C



By-Pass (01)



Through Drives

The C pump can be supplied with a through drive, which can operate in tandem with a second pump. Available flanges include SAE A, SAE B, SAE C, SAE B-B and SAE C-C flanges.

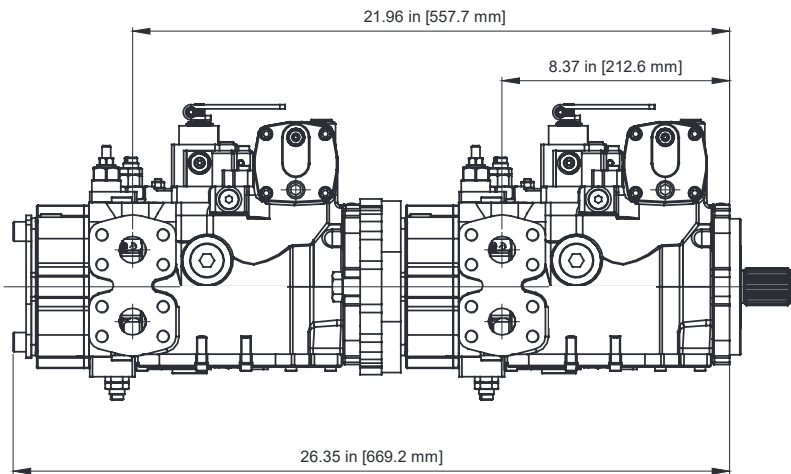
Maximum permissible drive-shaft torques for the first pump, as well as maximum through drive torques are listed in the table below.

WARNING:

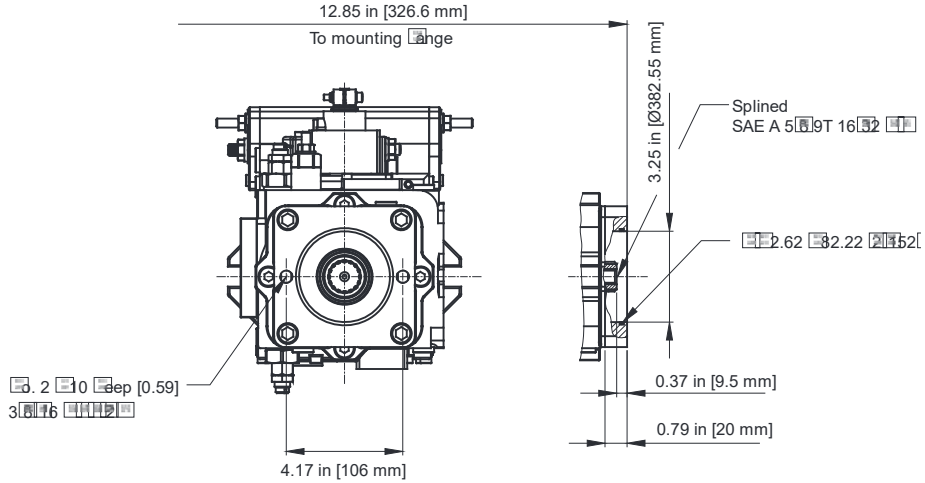
The effective torque value on the shaft of first pump is given by the sum of the torques required from each pump making the system.

Size		081	
Drive shaft		2 Z21 16/32 DP	1 Z14 12/24 DP
Drive shaft max torque	Nm [lbf-ft]	950 (700)	620 (457)
Through drive max torque	Nm [lbf-ft]	665 (490)	620 (457)

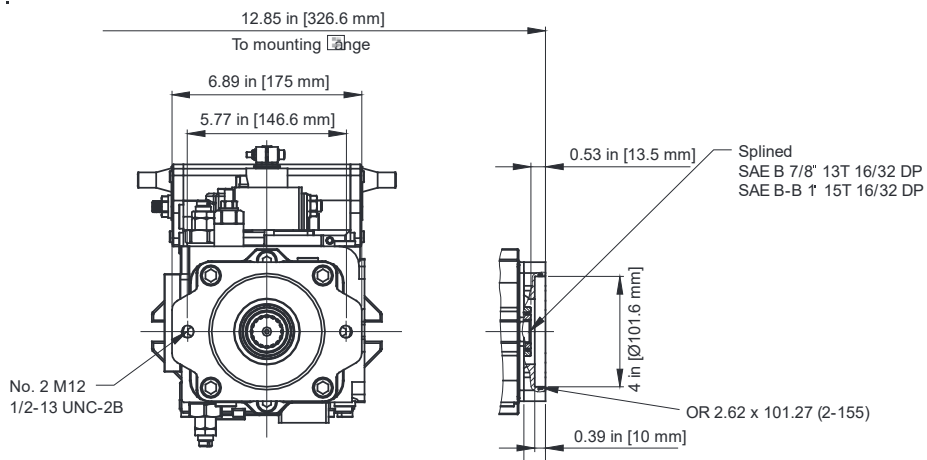
C081 Tandem for Reference



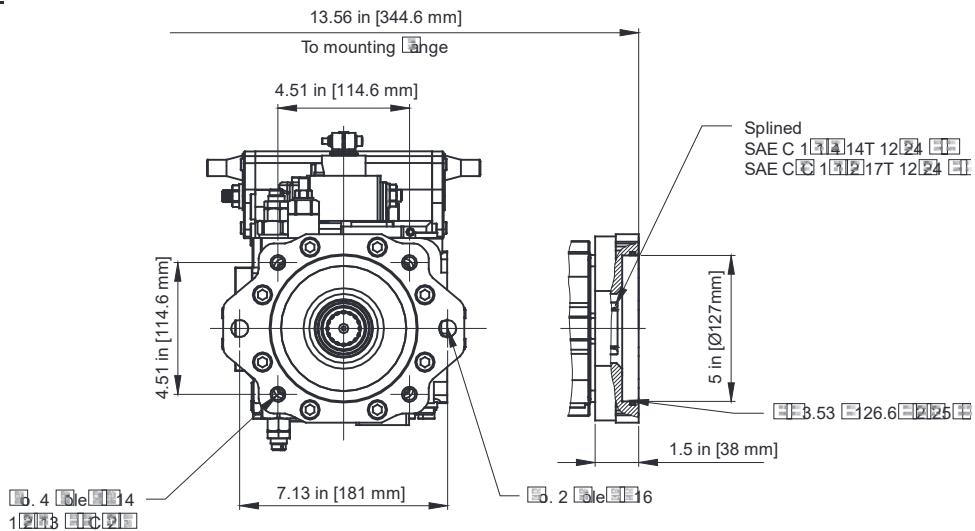
Through Drive Option A



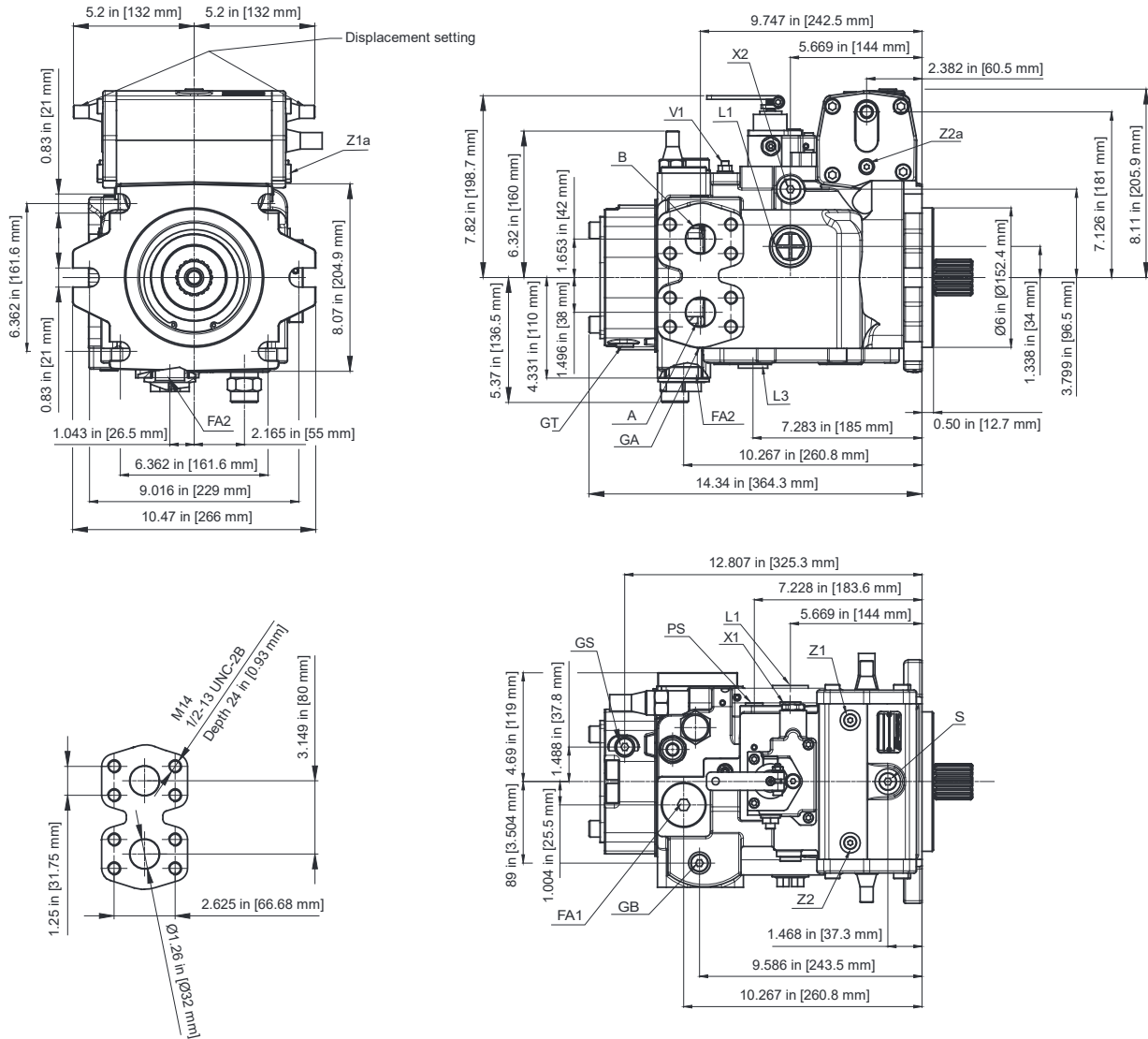
Through Drive Option B and G



Through Drive Option C and H



A Control

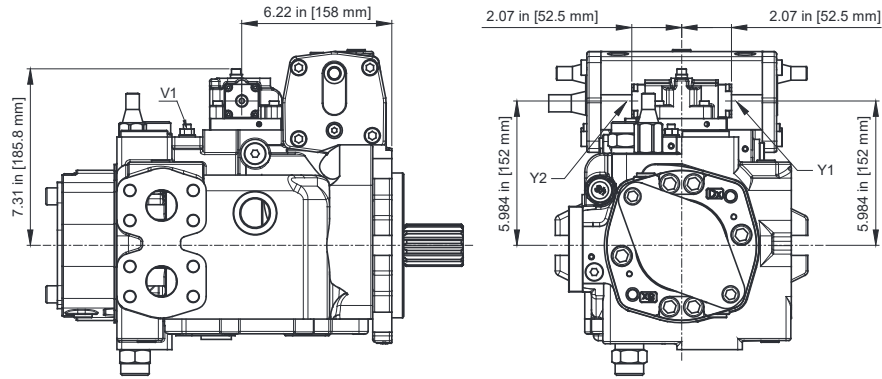


C136 Port Chart		
Port	Mount D	Mount H
A	1-1/4" SAE CODE 62	1-1/4" SAE CODE 62
B	1-1/4" SAE CODE 62	1-1/4" SAE CODE 62
L1	-16 SAE ORB	1" G
L2	-16 SAE ORB	1" G
L3	-12 SAE ORB	3/4" G
FA1	-20 SAE ORB	1-1/4" G
FA2	-20 SAE ORB	1-1/4" G
GA	-4 SAE ORB	1/4" G
GB	-4 SAE ORB	1/4" G

C136 Port Chart		
Port	Mount D	Mount H
GS	-4 SAE ORB	1/4" G
PS	-4 SAE ORB	1/4" G
Z1 (a)	-4 SAE ORB	1/8" G
Z2 (a)	-4 SAE ORB	1/8" G
X1	3/8" G	3/8" G
X2	3/8" G	3/8" G
Y1	4 SAE ORB	1/4" G
Y2	-4 SAE ORB	1/4" G
GT	-4 SAE ORB	1/4" G

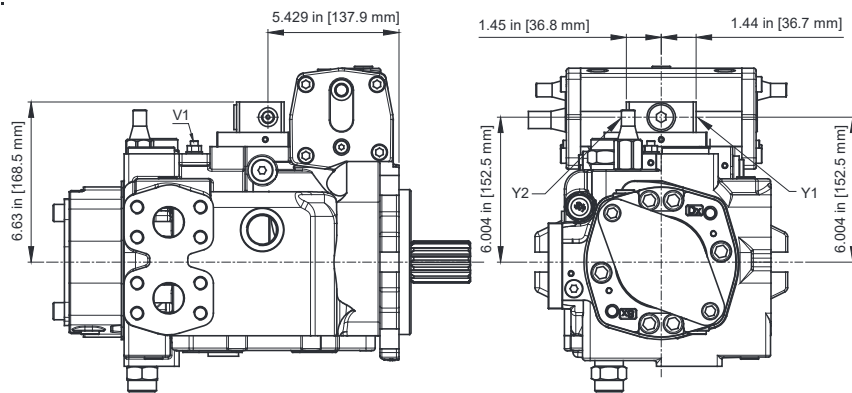


C Control



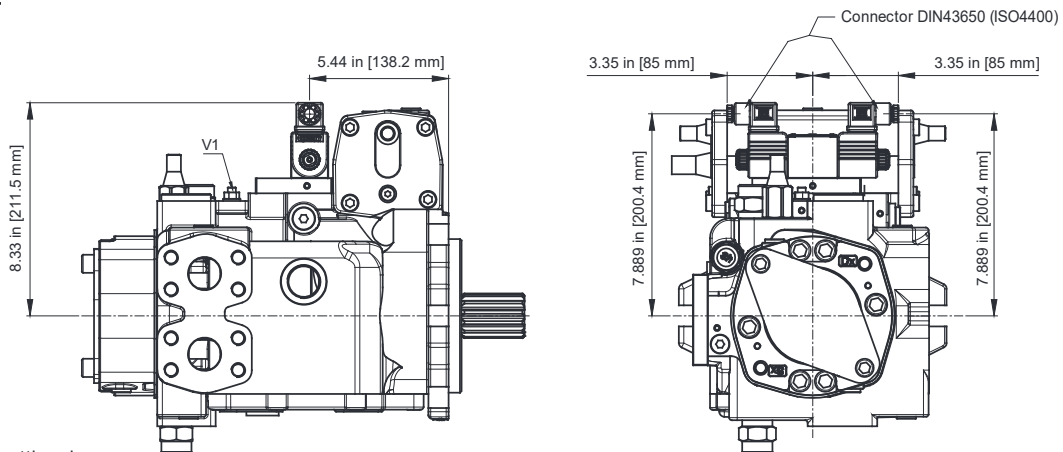
Y1-Y2: Control piloting pressure ports - 1/4 G (BSPP)
 S1-V1: Adjustable throttle valve

D Control



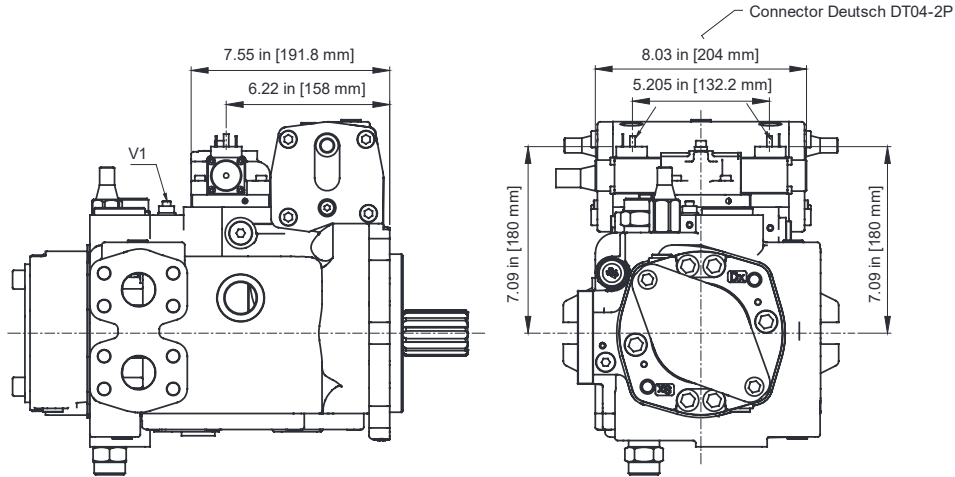
V1: Adjustable throttle valve

E Control



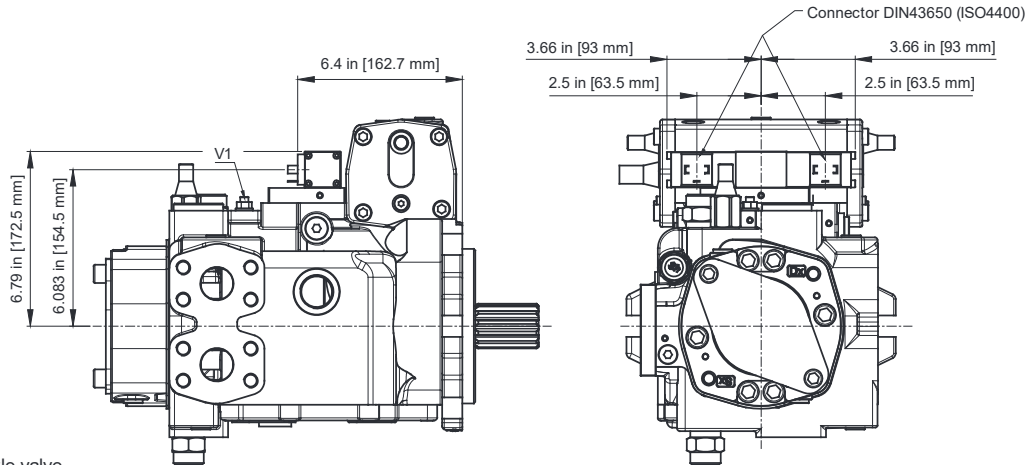
V1: Adjustable throttle valve

F Control



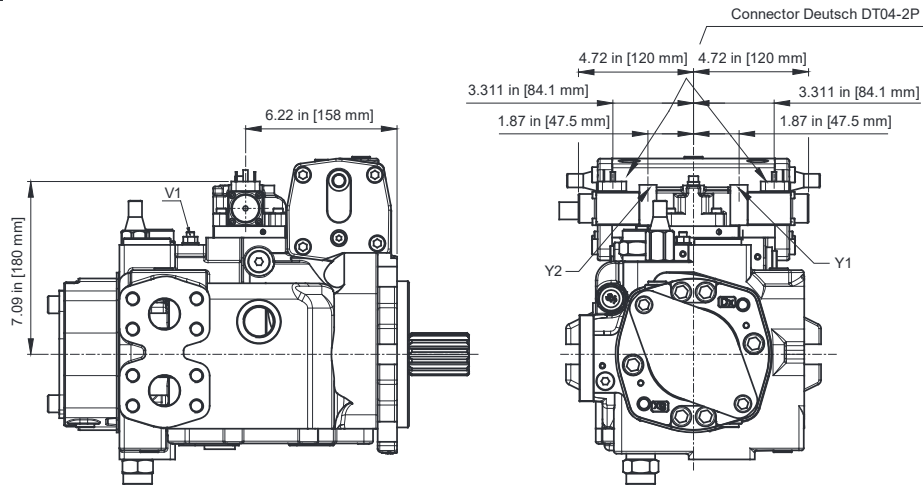
V1: Adjustable throttle valve

G Control



V1: Adjustable throttle valve

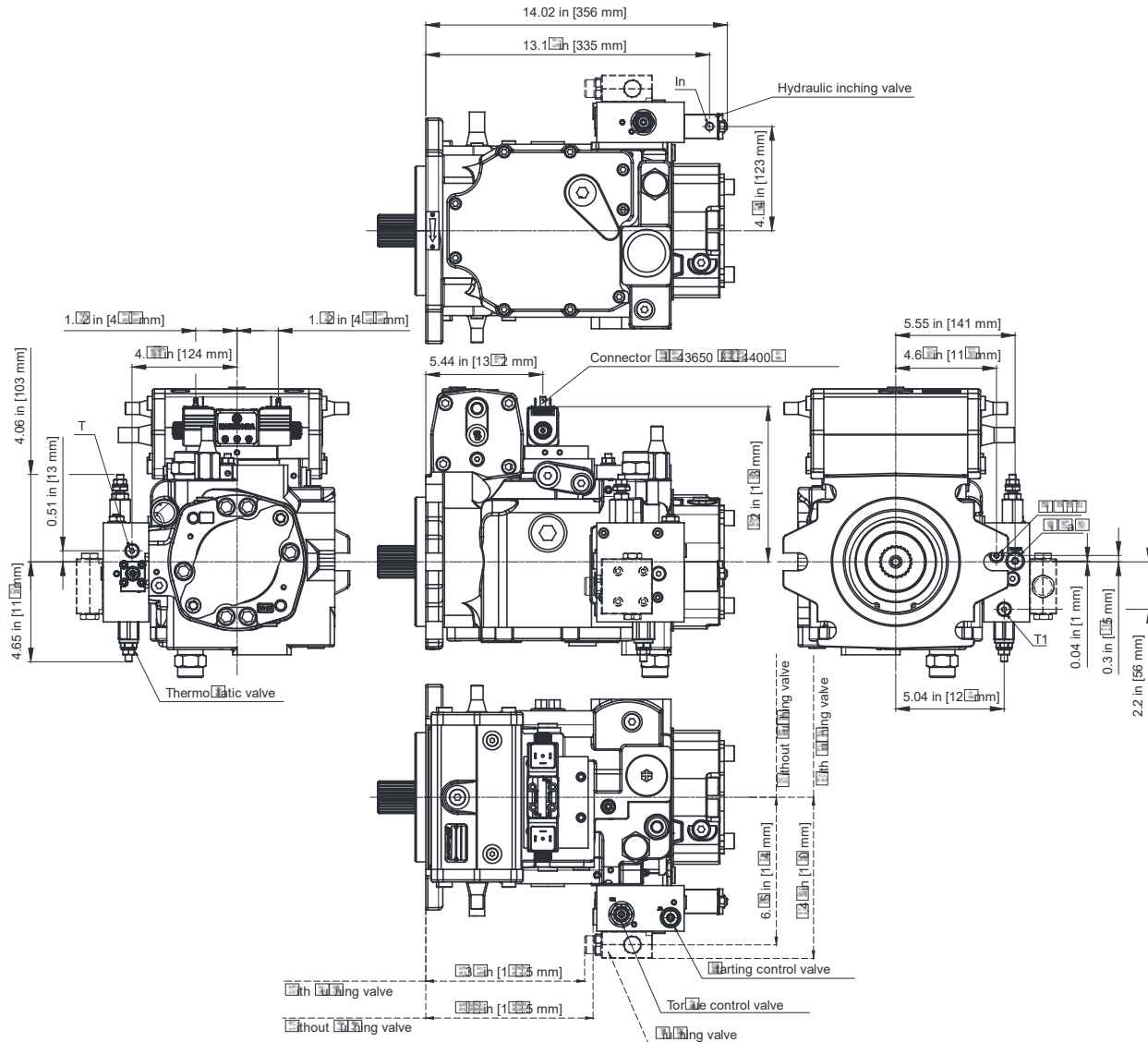
H Control



Y1-Y2: Control piloting pressure ports – 1/4" (BSPP)
 V1: Adjustable throttle valve



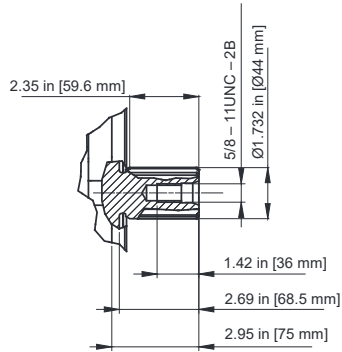
Automotive J With Hydraulic Inching



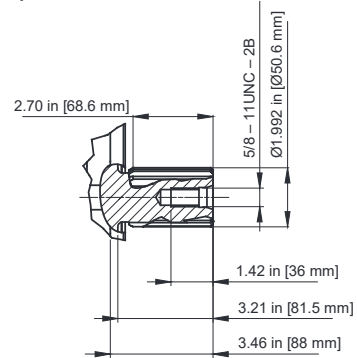
Pi Gas: Piloting pressure gauge port – 1/4 G (BSPP)
 Pi UNF: Piloting pressure gauge port – 7/16" - 20 UNF
 In: Piloting pressure inching port – 1/8 G (BSPP)
 T1: Drainage pressure gauge port – 1/8 G (BSPP)
 T: Drainage pressure gauge port – 1/4 G (BSPP)

Shaft

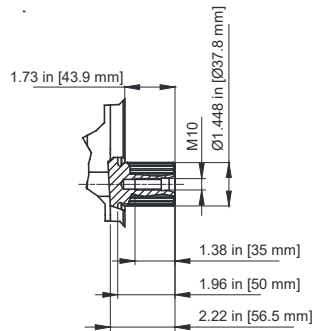
**3: Splined 13T 8/16 Dp ANSI B92.1a
 1976 Flat Root**



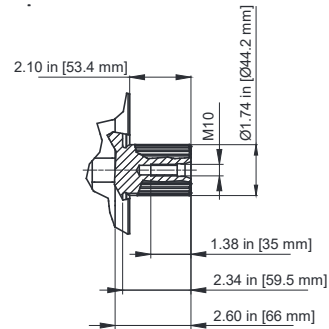
**4: Splined 15T 8/16 Dp ANSI B92.1a
 1976 Flat Root**



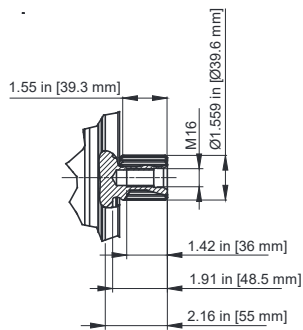
**5: Splined 23T 16/32 Dp ANSI B92.1a
 1976 Flat Root**



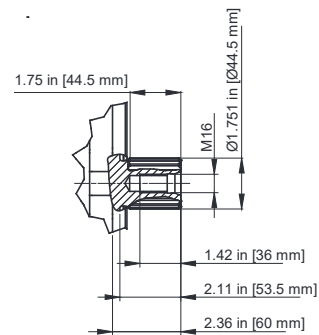
**6: Splined 27T 16/32 Dp ANSI B92.1a
 1976 Flat Root**



G: Splined W40x2x30x18 DIN 5480

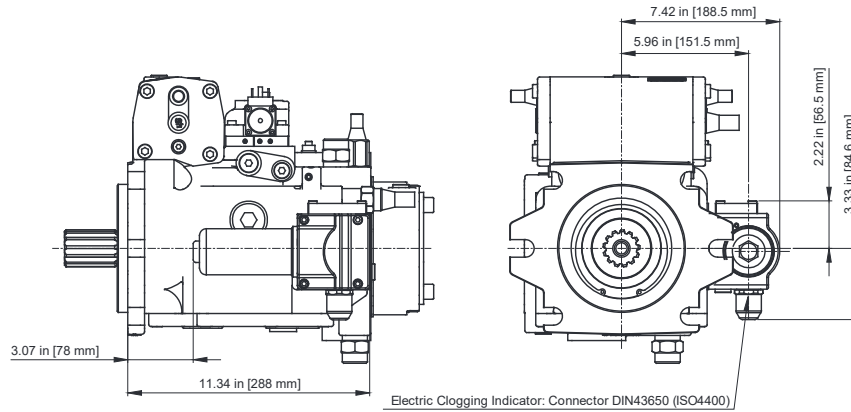


H: Splined W45x2x30x21 DIN 5480

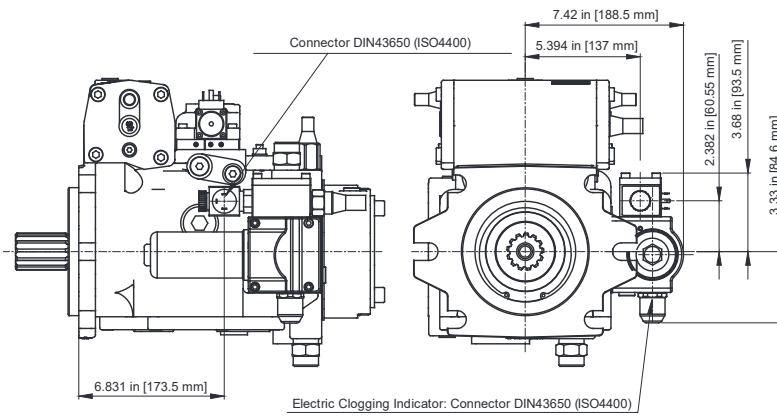


Pump and Accessories

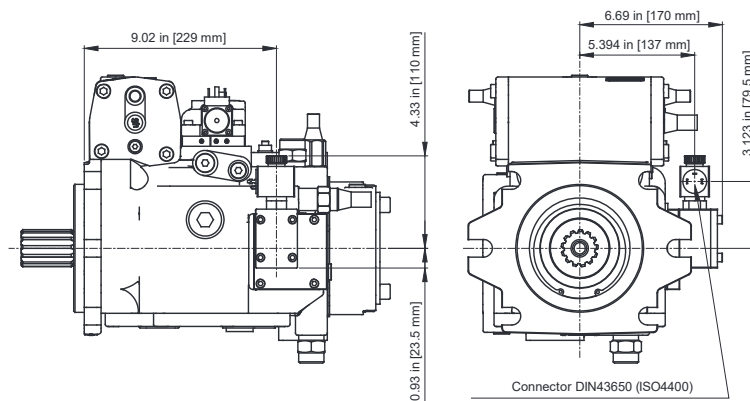
Filter



Filter and Override Option E



Filter and Override Option P



Through Drives

The C pump can be supplied with a through drive, which can operate in tandem with a second pump. Available flanges include SAE A, SAE B, SAE C, SAE B-B, SAE C-C and SAE-D.

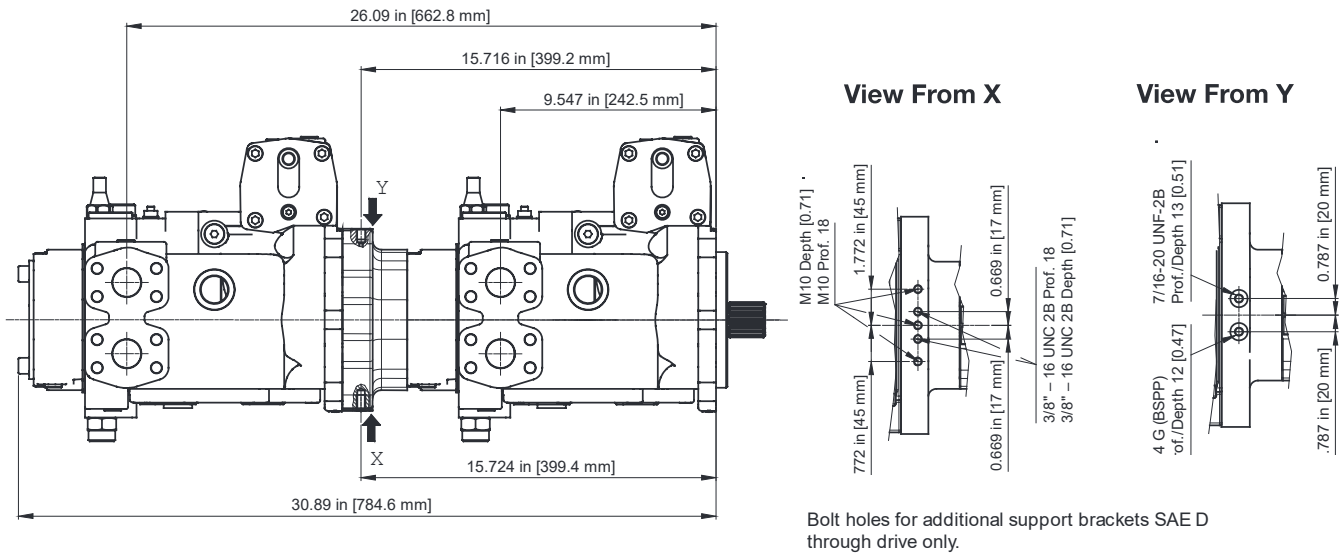
Maximum permissible drive-shaft torques for the first pump, as well as maximum through drive torques are listed in the table below.

WARNING:

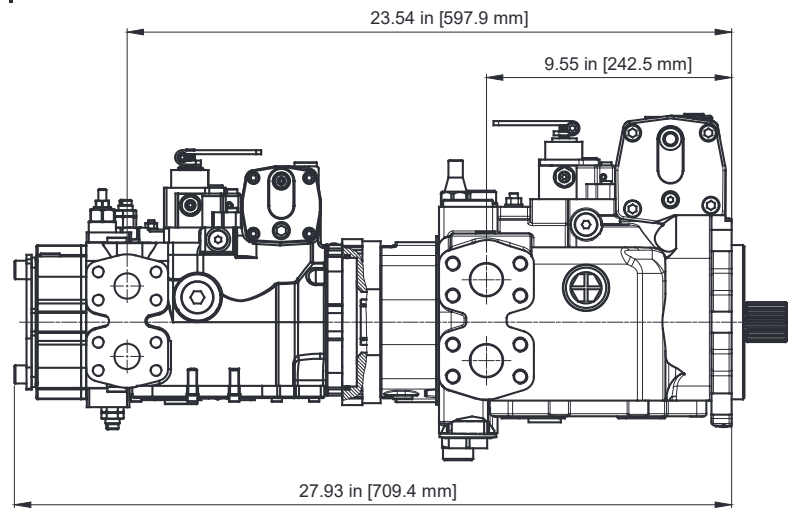
The effective torque value on the shaft of first pump is given by the sum of the torques required from each pump making the system.

Size		136					
Drive shaft		3	4	5	6	7	8
		Z13 8/16 DP	Z15 8/16 DP	Z23 16/32 DP	Z27 16/32 DP	W40x2x30x18	W45x2x30x21
Drive shaft max torque	Nm [lbf-ft]	1640 (1208)	2670 (1967)	1250 (921)	1900 (1400)	1460 (1076)	2190 (1614)
Through drive max torque	Nm [lbf-ft]	1000 (737)	1000 (737)	1000 (737)	1000 (737)	1000 (737)	1000 (737)

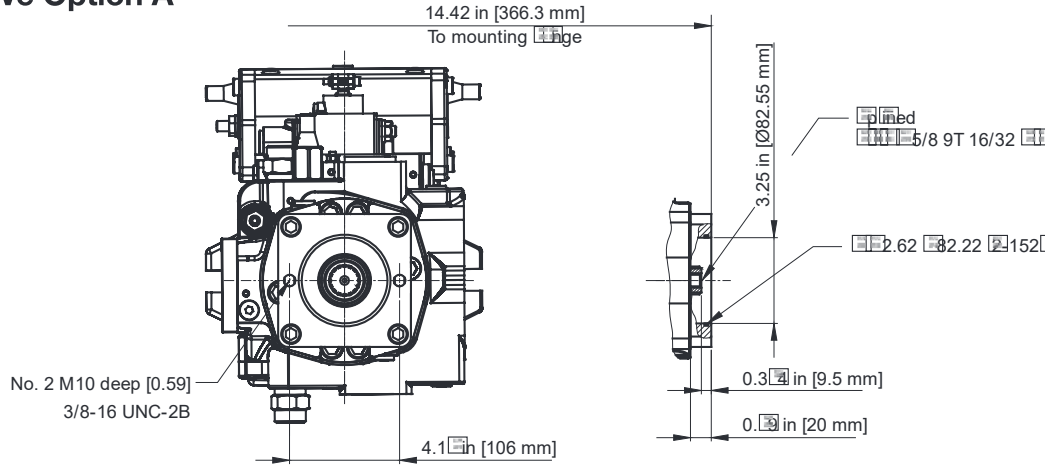
C136 Tandem for Reference



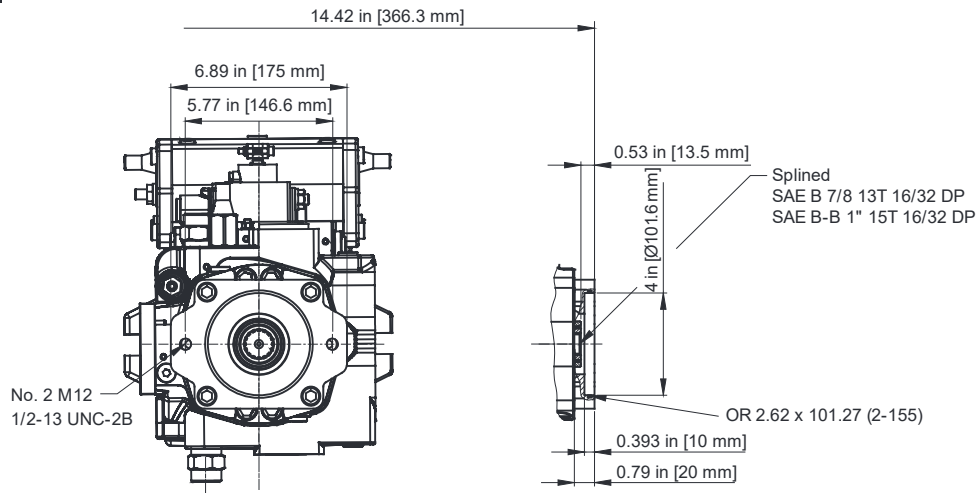
Tandem Combination C136 + C081



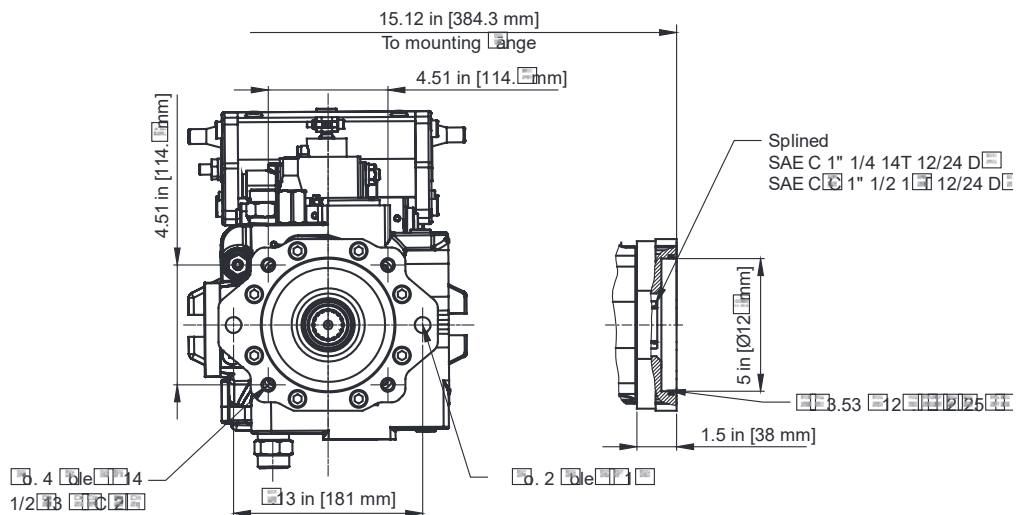
Through Drive Option A



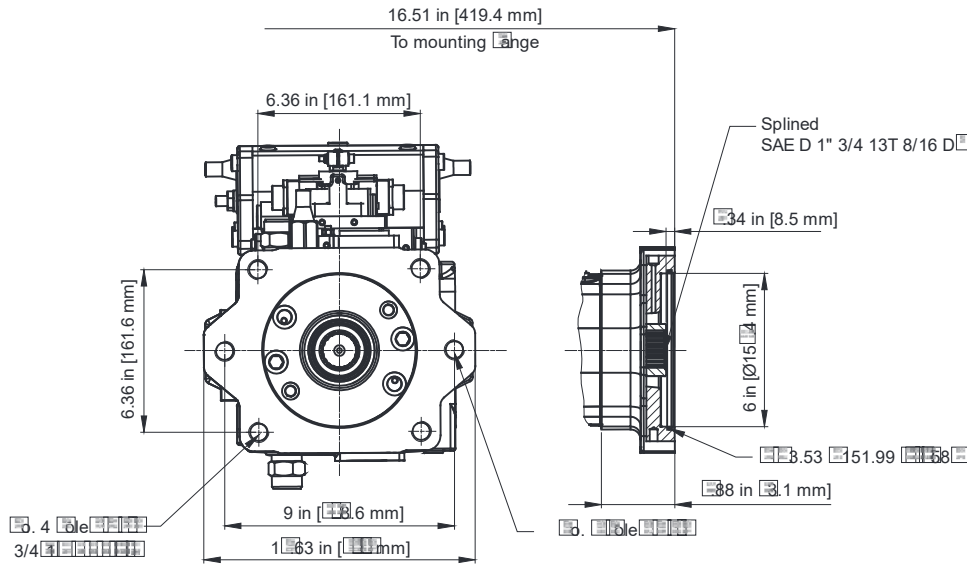
Through Drive Option B and G



Through Drive Option C and H



Through Drive Option D



General Installation Information

Installation Guidelines

Pump case should be filled prior to start up and plumbed to ensure it remains filled with fluid under all conditions. Pump case pressure should not exceed 4 bar (58 PSI) continuous pressure, 6 bar (87 PSI) on cold start up.

Care should be taken to ensure line velocities are not above standard design specifications as noted in Table 1. Raised line velocities will cause an increase in pressure loss in the hoses and cause premature failure under certain conditions. Pressure in the suction line of the pump should never be below .8 bar (11.6 PSI) absolute. Maximum suction pressure is 4 bar (58 psi) continuous and 6 bar (87 psi) on cold startup.

Long line lengths and sharp turns in the fluid conveyance will add additional pressure loss or restriction to the system. It is recommended to keep the line lengths as short as possible and to avoid as many fluid direction changes in the system as possible.

Table 1

Function	Fluid Velocity m/sec (Ft/sec)
Suction	0.6-1.2 (2-4)
Case drain	1.5-3 (5-10)
Pressure	3-6 (10-20)

Installation Orientation

The C Series pump can be installed in many different orientations; see Figure 1 for examples. If you are wanting to mount the unit in an orientation not shown please contact technical support.

It is suggested that the pump be mounted so that it is level or below minimum fluid level in the hydraulic reservoir. The pump can be mounted above fluid level but ensure the case remains filled at all times and proper suction pressure is maintained when mounting in this manner.

Regardless of installation orientation the highest case drain port (L1, L2 or L3) should always be used and should return below fluid level. See Figure 2 for drain port suggestions and suggested air bleed port.

Air bleed port should only be used while filling the case of the unit to ensure the unit is completely filled with fluid. Once unit is filled, the air bleed port should be closed via a port plug or shut off valve.

Fluid

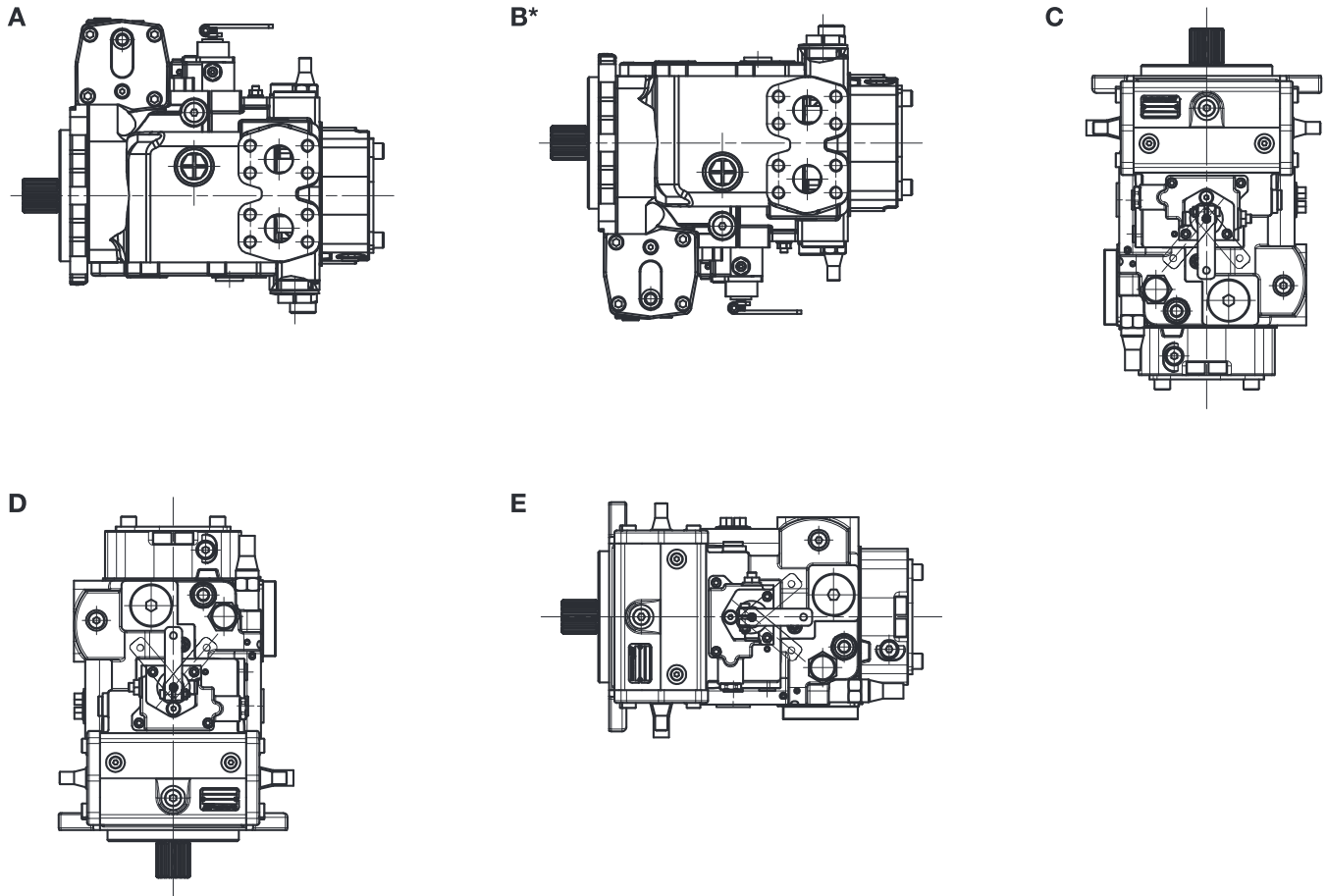
Parker recommends using a fluid with a petroleum base and contains agents which provide oxidation inhibition and anti-rust, anti-foam and deteriorating properties as described in Parker standard HF-1. Where anti-wear additive fluids are specified, see Parker standard HF-0.

Use fluids with a minimum Viscosity index of 90. Higher viscosity index extend the range of operating temperatures but may reduce the service life of the fluid.

It is recommended that the reservoir, hydraulic fluid and fluid conveyance items be cleaned prior to use. Filtration of the fluid is recommended before and during use. Maximum fluid contamination level is 20/18/15 per ISO 4406:1999. Better cleanliness levels will increase the life of the system.

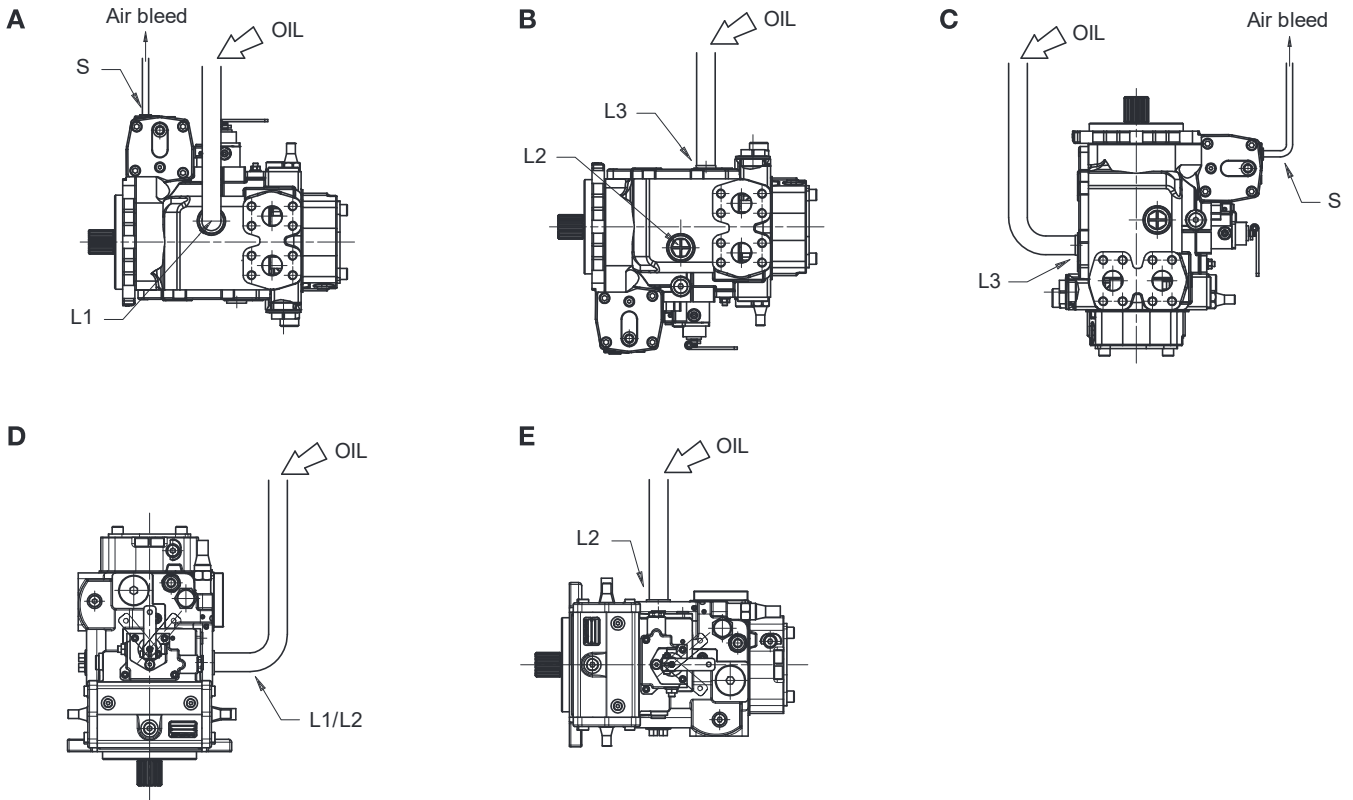


Figure 1: Optional Mounting Orientations



*Contamination can cause issues when mounting in this orientation.
Ensure system is clean when this orientation is used.

Figure 2: Case Drain and Air Bleed Recommendations



Customer must verify adequate cooling flow through pump case in their application.

Offer of Sale**Variable Displacement Axial Piston Pumps
C Series**

The items described in this document and other documents and descriptions provided by Parker Hannifin Corporation, its subsidiaries and its authorized distributors ("Seller") are hereby offered for sale at prices to be established by Seller. This offer and its acceptance by any customer ("Buyer") shall be governed by all of the following Terms and Conditions. Buyer's order for any item described in its document, when communicated to Seller verbally, or in writing, shall constitute acceptance of this offer. All goods, services or work described will be referred to as "Products".

1. **Terms and Conditions.** Seller's willingness to offer Products, or accept an order for Products, to or from Buyer is subject to these Terms and Conditions or any newer version of the terms and conditions found on-line at www.parker.com/saleterms/. Seller objects to any contrary or additional terms or conditions of Buyer's order or any other document issued by Buyer.
2. **Price Adjustments; Payments.** Prices stated on Seller's quote or other documentation offered by Seller are valid for 30 days, and do not include any sales, use, or other taxes unless specifically stated. Unless otherwise specified by Seller, all prices are F.C.A. Seller's facility (INCOTERMS 2010). Payment is subject to credit approval and is due 30 days from the date of invoice or such other term as required by Seller's Credit Department, after which Buyer shall pay interest on any unpaid invoices at the rate of 1.5% per month or the maximum allowable rate under applicable law.
3. **Delivery Dates; Title and Risk; Shipment.** All delivery dates are approximate and Seller shall not be responsible for any damages resulting from any delay. Regardless of the manner of shipment, title to any products and risk of loss or damage shall pass to Buyer upon placement of the products with the shipment carrier at Seller's facility. Unless otherwise stated, Seller may exercise its judgment in choosing the carrier and means of delivery. No deferral of shipment at Buyer's request beyond the respective dates indicated will be made except on terms that will indemnify, defend and hold Seller harmless against all loss and additional expense. Buyer shall be responsible for any additional shipping charges incurred by Seller due to Buyer's acts or omissions.
4. **Warranty.** Seller warrants that the Products sold hereunder shall be free from defects in material or workmanship for a period of eighteen months from the date of shipment from the Company. The prices charged for Seller's products are based upon the exclusive limited warranty stated above, and upon the following disclaimer: **DISCLAIMER OF WARRANTY: THIS WARRANTY COMPRISES THE SOLE AND ENTIRE WARRANTY PERTAINING TO PRODUCTS PROVIDED HEREUNDER. SELLER DISCLAIMS ALL OTHER WARRANTIES, EXPRESS AND IMPLIED, INCLUDING DESIGN, MERCHANTABILITY AND FITNESS FOR A PARTICULAR PURPOSE.**
5. **Claims; Commencement of Actions.** Buyer shall promptly inspect all Products upon delivery. No claims for shortages will be allowed unless reported to the Seller within 10 days of delivery. No other claims against Seller will be allowed unless asserted in writing within 30 days after delivery. Buyer shall notify Seller of any alleged breach of warranty within 30 days after the date the defect is or should have been discovered by Buyer. Any action based upon breach of this agreement or upon any other claim arising out of this sale (other than an action by Seller for an amount due on any invoice) must be commenced within 12 months from the date of the breach without regard to the date breach is discovered.
6. **LIMITATION OF LIABILITY. UPON NOTIFICATION, SELLER WILL, AT ITS OPTION, REPAIR OR REPLACE A DEFECTIVE PRODUCT, OR REFUND THE PURCHASE PRICE. IN NO EVENT SHALL SELLER BE LIABLE TO BUYER FOR ANY SPECIAL, INDIRECT, INCIDENTAL OR CONSEQUENTIAL DAMAGES ARISING OUT OF, OR AS THE RESULT OF, THE SALE, DELIVERY, NON-DELIVERY, SERVICING, USE OR LOSS OF USE OF THE PRODUCTS OR ANY PART THEREOF, OR FOR ANY CHARGES OR EXPENSES OF ANY NATURE INCURRED WITHOUT SELLER'S WRITTEN CONSENT, EVEN IF SELLER HAS BEEN NEGLIGENT, WHETHER IN CONTRACT, TORT OR OTHER LEGAL THEORY. IN NO EVENT SHALL SELLER'S LIABILITY UNDER ANY CLAIM MADE BY BUYER EXCEED THE PURCHASE PRICE OF THE PRODUCTS.**
7. **User Responsibility.** The user, through its own analysis and testing, is solely responsible for making the final selection of the system and Product and assuring that all performance, endurance, maintenance, safety and warning requirements of the application are met. The user must analyze all aspects of the application and follow applicable industry standards and Product information. If Seller provides Product or system options, the user is responsible for determining that such data and specifications are suitable and sufficient for all applications and reasonably foreseeable uses of the Products or systems.
8. **Loss to Buyer's Property.** Any designs, tools, patterns, materials, drawings, confidential information or equipment furnished by Buyer or any other items which become Buyer's property, will be considered obsolete and may be destroyed by Seller after two consecutive years have elapsed without Buyer ordering the items manufactured using such property. Seller shall not be responsible for any loss or damage to such property while it is in Seller's possession or control.
9. **Special Tooling.** A tooling charge may be imposed for any special tooling, including without limitation, dies, fixtures, molds and patterns, acquired to manufacture Products. Such special tooling shall be and remain Seller's property notwithstanding payment of any charges by Buyer. In no event will Buyer acquire any interest in apparatus belonging to Seller which is utilized in the manufacture of the Products, even if such apparatus has been specially converted or adapted for such manufacture and notwithstanding any charges paid by Buyer. Unless otherwise agreed, Seller shall have the right to alter, discard or otherwise dispose of any special tooling or other property in its sole discretion at any time.
10. **Buyer's Obligation; Rights of Seller.** To secure payment of all sums due or otherwise, Seller shall retain a security interest in the goods delivered and this agreement shall be deemed a Security Agreement under the Uniform Commercial Code. Buyer authorizes Seller as its attorney to execute and file on Buyer's behalf all documents Seller deems necessary to perfect its security interest.
11. **Improper use and Indemnity.** Buyer shall indemnify, defend, and hold Seller harmless from any claim, liability, damages, lawsuits, and costs (including

- attorney fees), whether for personal injury, property damage, patent, trademark or copyright infringement or any other claim, brought by or incurred by Buyer, Buyer's employees, or any other person, arising out of: (a) improper selection, improper application or other misuse of Products purchased by Buyer from Seller; (b) any act or omission, negligent or otherwise, of Buyer; (c) Seller's use of patterns, plans, drawings, or specifications furnished by Buyer to manufacture Product; or (d) Buyer's failure to comply with these terms and conditions. Seller shall not indemnify Buyer under any circumstance except as otherwise provided.
12. **Cancellations and Changes.** Orders shall not be subject to cancellation or change by Buyer for any reason, except with Seller's written consent and upon terms that will indemnify, defend and hold Seller harmless against all direct, incidental and consequential loss or damage. Seller may change product features, specifications, designs and availability with notice to Buyer.
 13. **Limitation on Assignment.** Buyer may not assign its rights or obligations under this agreement without the prior written consent of Seller.
 14. **Force Majeure.** Seller does not assume the risk and shall not be liable for delay or failure to perform any of Seller's obligations by reason of circumstances beyond the reasonable control of Seller (hereinafter "Events of Force Majeure"). Events of Force Majeure shall include without limitation: accidents, strikes or labor disputes, acts of any government or government agency, acts of nature, delays or failures in delivery from carriers or suppliers, shortages of materials, or any other cause beyond Seller's reasonable control.
 15. **Waiver and Severability.** Failure to enforce any provision of this agreement will not waive that provision nor will any such failure prejudice Seller's right to enforce that provision in the future. Invalidation of any provision of this agreement by legislation or other rule of law shall not invalidate any other provision herein. The remaining provisions of this agreement will remain in full force and effect.
 16. **Termination.** Seller may terminate this agreement for any reason and at any time by giving Buyer thirty (30) days written notice of termination. Seller may immediately terminate this agreement, in writing, if Buyer: (a) commits a breach of any provision of this agreement (b) appoints a trustee, receiver or custodian for all or any part of Buyer's property (c) files a petition for relief in bankruptcy on its own behalf, or by a third party (d) makes an assignment for the benefit of creditors, or (e) dissolves or liquidates all or a majority of its assets.
 17. **Governing Law.** This agreement and the sale and delivery of all Products hereunder shall be deemed to have taken place in and shall be governed and construed in accordance with the laws of the State of Ohio, as applicable to contracts executed and wholly performed therein and without regard to conflicts of laws principles. Buyer irrevocably agrees and consents to the exclusive jurisdiction and venue of the courts of Cuyahoga County, Ohio with respect to any dispute, controversy or claim arising out of or relating to this agreement.
 18. **Indemnity for Infringement of Intellectual Property Rights.** Seller shall have no liability for infringement of any patents, trademarks, copyrights, trade dress, trade secrets or similar rights except as provided in this Section. Seller will defend and indemnify Buyer against allegations of infringement of U.S. patents, U.S. trademarks, copyrights, trade dress and trade secrets ("Intellectual Property Rights"). Seller will defend at its expense and will pay the cost of any settlement or damages awarded in an action brought against Buyer based on an allegation that a Product sold pursuant to this Agreement infringes the Intellectual Property Rights of a third party. Seller's obligation to defend and indemnify Buyer is contingent on Buyer notifying Seller within ten (10) days after Buyer becomes aware of such allegations of infringement, and Seller having sole control over the defense of any allegations or actions including all negotiations for settlement or compromise. If a Product is subject to a claim that it infringes the Intellectual Property Rights of a third party, Seller may, at its sole expense and option, procure for Buyer the right to continue using the Product, replace or modify the Product so as to make it noninfringing, or offer to accept return of the Product and return the purchase price less a reasonable allowance for depreciation. Notwithstanding the foregoing, Seller shall have no liability for claims of infringement based on information provided by Buyer, or directed to Products delivered hereunder for which the designs are specified in whole or part by Buyer, or infringements resulting from the modification, combination or use in a system of any Product sold hereunder. The foregoing provisions of this Section shall constitute Seller's sole and exclusive liability and Buyer's sole and exclusive remedy for infringement of Intellectual Property Rights.
 19. **Entire Agreement.** This agreement contains the entire agreement between the Buyer and Seller and constitutes the final, complete and exclusive expression of the terms of sale. All prior or contemporaneous written or oral agreements or negotiations with respect to the subject matter are herein merged.
 20. **Compliance with Law, U. K. Bribery Act and U.S. Foreign Corrupt Practices Act.** Buyer agrees to comply with all applicable laws and regulations, including both those of the United Kingdom and the United States of America, and of the country or countries of the Territory in which Buyer may operate, including without limitation the U. K. Bribery Act, the U.S. Foreign Corrupt Practices Act ("FCPA") and the U.S. Anti-Kickback Act (the "Anti-Kickback Act"), and agrees to indemnify and hold harmless Seller from the consequences of any violation of such provisions by Buyer, its employees or agents. Buyer acknowledges that they are familiar with the provisions of the U. K. Bribery Act, the FCPA and the Anti-Kickback Act, and certifies that Buyer will adhere to the requirements thereof. In particular, Buyer represents and agrees that Buyer shall not make any payment or give anything of value, directly or indirectly to any governmental official, any foreign political party or official thereof, any candidate for foreign political office, or any commercial entity or person, for the purpose of influencing such person to purchase products or otherwise benefit the business of Seller. 04/2014

Revisions

January 2017- added 55cc information, added updated model code information, removed B control option, other cosmetic updates and minor corrections applied.

June 2017- correction to flow direction charts, minor updates to pump layout drawings and port call outs.

Parker Hannifin Corporation
Hydraulic Pump and Power Systems Division
14249 Industrial Pkwy.
Marysville, OH 43040
phone 937 644 3915
fax 937 642 3738
www.parker.com/hps

