

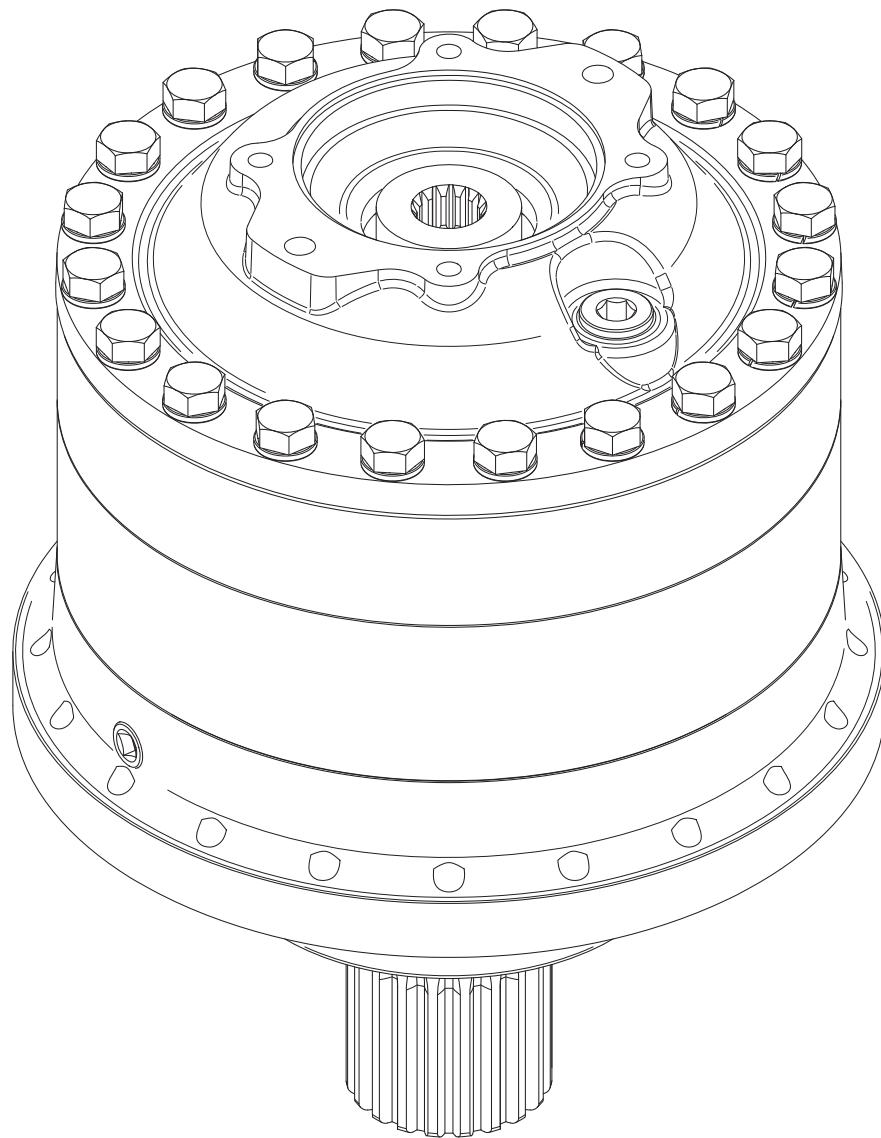

MODEL 254L PLANETARY GEAR DRIVE SERVICE MANUAL



WARNING: While working on this equipment, use safe lifting procedures, wear adequate clothing and wear hearing, eye and respiratory protection.

THIS SERVICE MANUAL IS EFFECTIVE:

S/N: 69255 TO CURRENT

DATE: 1/12/2006 TO CURRENT

VERSION: SM254L-BD

NOTE: Individual customer specifications (mounting case, output shaft, brake assembly, etc.) may vary from exploded drawing and standard part numbers shown. If applicable, refer to customer drawing for details.



ESKRIDGE MODEL 254L

EQUIPPED WITH
"LOAD-N-LOCK"[®]
SHAFT RETENTION
SYSTEM

ITEM	QTY	RATIO →	20.25:1	26.34:1	29.58	40.24:1
			4.3125:1 4.6957:1	5.609:1 4.6957:1	6.3:1 4.6957:1	8.57:1 4.6957:1
		DESCRIPTION	PART NO.	PART NO.	PART NO.	PART NO.
1	1	250A BASE - ROUND	25-004-3042	25-004-3042	25-004-3042	25-004-3042
		250F BASE - FLANGELESS	25-004-3052	25-004-3052	25-004-3052	25-004-3052
		250Q BASE - ECCENTRIC PILOT	25-004-3132	25-004-3132	25-004-3132	25-004-3132
		CUSTOM BASE	-	-	-	-
2	1	RING GEAR - PRIMARY	25-004-1562	25-004-1562	25-004-1562	25-004-1562
3	1	RING GEAR - SECONDARY	25-004-1612	25-004-1612	25-004-1612	25-004-1612
4	1	A - SAE 'A' COVER	25-005-2061	25-005-2061	25-005-2061	25-005-2061
		B - SAE 'B' COVER	25-005-2051	25-005-2051	25-005-2051	25-005-2051
		C - SAE 'C' (2 AND 4 BOLT)	25-004-1222	25-004-1222	25-004-1222	25-004-1222
		D - SAE 'D' COVER	25-004-1232	25-004-1232	25-004-1232	25-004-1232
5	1	CARRIER - PRIMARY	25-004-1692	25-004-1642	25-004-1702	25-004-1412
6	1	CARRIER - SECONDARY	25-004-1602	25-004-1602	25-004-1602	25-004-1602
7	1	D1 - OUTPUT SHAFT 20T 6/12 SPLINE	25-004-4032L	25-004-4032L	25-004-4032L	25-004-4032L
		D2 - OUTPUT SHAFT 3.75" DIA, KEYED	25-004-4042L	25-004-4042L	25-004-4042L	25-004-4042L
		S1 - OUTPUT SHAFT SPINDLE 9.0" PILOT	25-004-4062L	25-004-4062L	25-004-4062L	25-004-4062L
		C1 - OUTPUT SHAFT - CUSTOM	-	-	-	-
8	4	PLANET GEAR - SECONDARY	25-004-1632	25-004-1632	25-004-1632	25-004-1632
9	1	SUN GEAR - SECONDARY	25-004-1622	25-004-1622	25-004-1622	25-004-1622
10	3	PLANET GEAR - PRIMARY	25-004-1712	25-004-1652	25-004-1722	25-004-1552
11	1	INPUT GEAR INPUT 14T SPL	25-004-1732	25-004-1792	25-004-1742	25-004-1812
		INPUT GEAR INPUT 13T SPL	25-004-1762	25-004-1802	25-004-1772	25-004-1782
12	4	PLANET SHAFT - SECONDARY	25-004-1432	25-004-1432	25-004-1432	25-004-1432
13	3	PLANET SHAFT - PRIMARY	25-004-1442	25-004-1442	25-004-1442	25-004-1442
14	2	THRUST WASHER - CARRIER	25-004-1132	25-004-1132	25-004-1132	25-004-1132
15	3	SEAL (O-RING)	01-402-0020	01-402-0020	01-402-0020	01-402-0020
16	6	THRUST WASHER - PRI. PLANET	13-004-1582	13-004-1582	13-004-1582	13-004-1582
17	8	THRUST WASHER - SEC. PLANET	25-004-1462	25-004-1462	25-004-1462	25-004-1462
18	1	SPLIT RING- LOAD-N-LOCK	25-004-1182	25-004-1182	25-004-1182	25-004-1182
19	1	BEARING CONE - OUTER	01-102-0120	01-102-0120	01-102-0120	01-102-0120
20	1	BEARING CUP - OUTER	01-103-0110	01-103-0110	01-103-0110	01-103-0110
21	1	BEARING CONE - INNER	01-102-0250	01-102-0250	01-102-0250	01-102-0250
22	1	BEARING CUP - INNER	01-103-0250	01-103-0250	01-103-0250	01-103-0250
23	180	ROLLER (SEC = 2 X 18, PRI = 1 X 12)	01-106-0010	01-106-0010	01-106-0010	01-106-0010
24	4	SPACER - SEC PLANET BEARING	25-004-1452	25-004-1452	25-004-1452	25-004-1452
25	12	SPACER - PRI PLANET BEARING	13-004-1592	13-004-1592	13-004-1592	13-004-1592
26	*	SHIM - SHAFT ADJUSTMENT	25-004-1051	25-004-1051	25-004-1051	25-004-1051
27	1	LOCK RING - LOAD-N-LOCK	25-004-1192	25-004-1192	25-004-1192	25-004-1192
28	1	THRUST WASHER - INPUT GEAR	25-004-1752	25-004-1752	25-004-1752	25-004-1752
29	20	HEX HEAD CAPSCREW (5/8-11 X 7) GR 8	01-150-1630	01-150-1630	01-150-1630	01-150-1630
30	3	ROLL PIN (3/16 X 1)	01-153-0020	01-153-0020	01-153-0020	01-153-0020
31	4	ROLL PIN (3/16 X 1 1/4)	01-153-0190	01-153-0190	01-153-0190	01-153-0190
32	20	LOCKWASHER - (5/8)	01-166-0040	01-166-0040	01-166-0040	01-166-0040
33	1	PIPE PLUG (1/2 NPT MAGNETIC) - BASE	01-207-0041	01-207-0041	01-207-0041	01-207-0041
34	1	PLUG - COVER	01-208-0030	01-208-0030	01-208-0030	01-208-0030
35	1	SHAFT SEAL	01-405-0740	01-405-0740	01-405-0740	01-405-0740
36	1	PLUG 1/4 NPT	01-207-0020	01-207-0020	01-207-0020	01-207-0020
		GREASE FITTING (OPTIONAL)	01-215-0040	01-215-0040	01-215-0040	01-215-0040

* QUANTITY OF SHIMS DETERMINED BY BEARING PRELOAD.

OPTIONS SEAL KIT P/N 25-016-2061
INCLUDES 1 EA. OF ITEMS 35
AND A QTY 3 OF ITEM 15

X254LD2-Bd ECN: 4078 DATE: 04-17-17 MTK

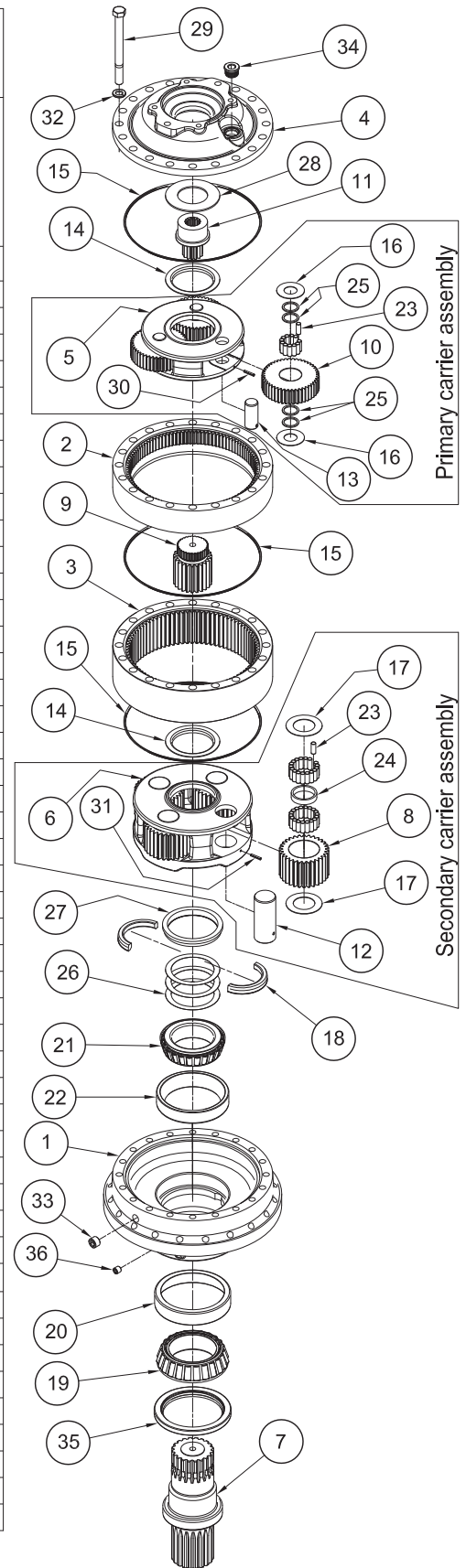

X254L-D2-Bd,
Effective date 1/12/2006
Effective serial # 69255

LUBRICATION & MAINTENANCE

Using the chart below, determine an appropriate lubricant viscosity. Use only EP (extreme pressure) or API GL-5 designated lubricants. Change the lubricant after the first 50 hours of operation and at 500 hour intervals thereafter. The gear drive should be partially disassembled to inspect gears and bearings at 1000 hour intervals.



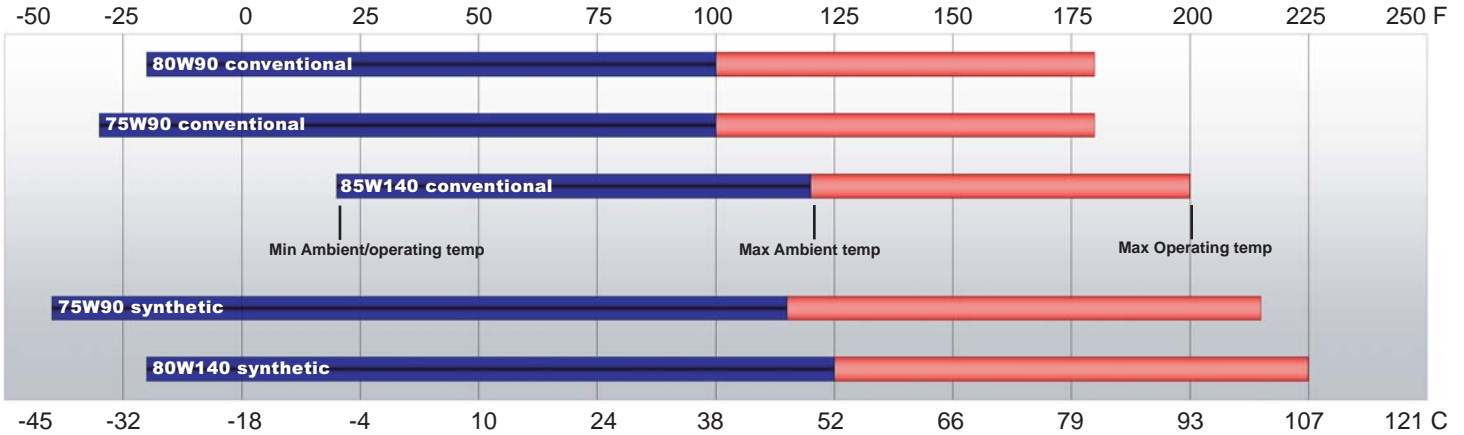



Recommended ambient and operating temperatures for conventional and synthetic gear lubricants



Note: Ambient temperature is the air temperature measured in the immediate vicinity of the gearbox. A Gearbox exposed to the direct rays of the sun or other radiant heat sources will operate at higher temperatures and therefore must be given special consideration. The max operating temp must not be exceeded under any circumstances, regardless of ambient temperature.

If your unit was specified "shaft up" or with a "-Z" option, a grease zerk was provided in the base housing. For shaft-up operation, the output bearing will not run in oil and must be grease lubricated. Use a lithium based or general purpose bearing grease sparingly every 50 operating hours or at regular maintenance intervals. Over-greasing the output bearing should be avoided as it tends to fill the housing with grease and thicken the oil

ESKRIDGE MODEL 254L OIL CAPACITIES

Operating Position	Oil Capacity	Oil Level
 Horizontal Shaft	3.0 qts / 2.8 l	To horizontal centerline of gear drive 
 Vertical Shaft (Pinion Up)	5.0 qts / 4.7 l	To side port on gear drive base 
 Vertical Shaft (Pinion Down)	5.0 qts / 4.7 l	To midway on upper/primary gear set 

ESKRIDGE PART NUMBER INTERPRETATION

Note: All non custom Eskridge Geardrives are issued a descriptive part number which includes information regarding the Model, means of shaft retention, base style, shaft style, input mounting, input shaft size, overall ratio and various available options. For a detailed breakdown of this information, please refer to Eskridge product specification sheets found at: <http://www.eskridgeinc.com/geardrives/gearprodspecs.html>

Unit Teardown

- 1) Scribe a line across the outside of the unit from the cover (4) to the base (1) before disassembly to aid in the proper positioning of pieces during reassembly.
- 2) Remove drain plugs (33) and drain oil from unit. The oil will drain out more quickly and completely if warm.
- 3) Remove the twenty 5/8-11 capscrews (29) and lockwashers (32).
- 4) Remove the cover (4), thrust washer (28), input gear (11) and carrier thrust washer (14). Inspect o-ring (15); discard if damaged or deformed.
- 5) Lift the planet carrier assembly (includes items 5, 10, 13, 16, 24, 25 & 30) out of the unit.
- 6) If the sun gear (9) has not been removed from the gearbox, do so now. (Sometimes the sun gear remains in the primary carrier (5)).
- 7) Remove the primary ring gear (2). Inspect second o-ring (15), as before; discard if damaged.
- 8) Remove the secondary ring gear (3). Inspect third o-ring (15), as before; discard if damaged.
- 9) Remove carrier thrust washer (14). Lift the secondary planetary assembly out of the unit (includes items 6, 8, 12, 17, 23, 24 & 31). Use a puller if necessary.
- 10) The unit is now disassembled into groups of parts. The area(s) requiring repair should be identified by thorough inspection of the individual components after they have been cleaned and dried.

Carrier Assembly Teardown

Rotate planet gears (10 pri/8 sec) to check for abnormal noise or roughness in bearings (23 pri/23 sec). If further inspection or replacement is required, proceed as follows.

- 1) Drive roll pins (30 pri/31 sec) completely into the planet shafts (13 pri/12 sec).
- 2) Slide planet shafts (13 pri/12 sec) out of carrier (5 pri/6 sec).
- 3) Remove planet gears (13 pri/12 sec), washers (16 pri/17 sec), spacers (25 pri/24 sec) and bearings (23 pri/23 sec) from carrier (5 pri/6 sec).
- 4) Inspect the planet gear (10 pri/8 sec), bearing bore and planet shaft (13 pri/12 sec) and bearing rollers (23 pri/23 sec). Check for spalling, bruising or other damage and replace components as necessary. *Note: When using loose (uncaged individual) rollers, all rollers in the planet gear must be replaced if any are found to be defective (and likely the planet shaft and planet gear as well).*
- 5) Remove roll pins (30 pri/31 sec) from planet shafts (13 pri/12 sec) using a 1/16 pri/ 3/16 sec inch pin punch.

Carrier Reassembly

- 1) Loose roller installation:

- a) Set planet washer (16 pri/17 sec) on work table with planet gear (10 pri/8 sec) on top of it. Center planet washer to planet gear as closely as possible.
- b) Center planet shaft (13 pri/12 sec) in planet gear (10 pri/8 sec) bearing bore.
- c) If used, place spacer washer (25 pri/24 sec) onto planet shaft (refer to exploded view to confirm spacer positions).
- d) Begin placing rollers (23 pri/23 sec) around shaft (13 pri/12 sec). There should be clearance for last roller to slide in. Be sure to install 12 rollers (pri) or 2 rows of 18 rollers (sec) rollers in each planet gear (10 pri/8 sec) on loose roller applications.

(If using multiple rows of rollers, repeat steps C and D as necessary. Once complete, refer to exploded view to confirm that any spacer washers (7F pri/ 5F sec) are appropriately placed.)
- e) Place a washer (16 pri/17 sec) over gear (10 pri/8 sec) and onto shaft (13 pri/12 sec).
- f) Carefully slide assembly off of table, holding planet washers (16 pri/17 sec) against planet gear (10 pri/8 sec).
- g) Slide planet shaft (13 pri/12 sec) out of the assembly and slide assembly into carrier.
- h) Align planet gear & bearing assembly inside carrier and install planet shaft through entire assembly. Use grease to hold the rollers if necessary.

- 2) Planet shafts (13 pri/12 sec) should be installed with chamfered end of 1/16 pri/ 3/16 sec inch roll pin hole towards outside diameter of carrier (5 pri/6 sec); this will ease alignment of holes while inserting roll pins (30 pri/31 sec).

- 3) Drive roll pin (30 pri/31 sec) into the carrier hole and into planet shaft to retain parts. Repeat for remaining planet gears.

Base Subassembly Teardown

- 1) Remove the lock ring (27) using a heel bar or puller; if using a heel bar, be sure **not** to pry against the cage of the inner output shaft bearing (21). Remove the split ring segments (18) and shims (26).

Caution: Since the shaft is no longer positively retained, care should be taken to avoid personal injury. Care should also be taken not to damage it while pressing through base.

Note: Removing the shaft from the base assembly damages the shaft seal (35) and the seal will need to be replaced.

- 2) Place base (1) external side down, on a plate or table. Press output shaft (7) out bottom of base (1) by applying a load to internal end of shaft until it passes through inner shaft bearing cone (21).
- 3) A gear puller may be used to remove the outer bearing cone (19) from the shaft (7). If reusing old bearing cone,

do not pull on or damage roller cage. Remove the shaft seal (35) for replacement.

- 4) Lubricate inner lip of new shaft seal (35) and slide it onto the shaft (7) until it fits snugly over the shaft seal diameter with the open side toward the inside of the gear drive.

Note: Press bearing cone onto output shaft by pressing on inner race only. DO NOT press on roller cage, as it will damage bearing.

- 5) Inspect inner and outer bearing cups (22 & 20). If cups are damaged, drive them out using a brass drift and utilizing the bearing knock-out notches in the base (1)

Base Reassembly

- 1) Clean all foreign material from magnetic oil plug located on base (1).
- 2) Place base (1) exterior side up on work table.
- 3) Apply a layer of lithium or general purpose bearing grease to the roller contact surface of outer bearing cup (20). If unit is a spindle-shaft style and if equipped with optional boot (01-406-0050), install boot now.
- 4) Press outer bearing cone (19) onto the shaft until it seats against the shoulder.
- 5) Place the shaft (7) with the bearing (19) and seal (35) into the base (1). For a spindle shaft, use either a split-type spacer with handles on it to force seal into bore without damaging the seal can or use 4 (or more) 1" wide bars 1/2" thick to force seal can into seal bore. Spread an even layer of Loctite 645 purple or similar thread-sealant on O.D. of seal can prior to installation.
- 6) Flip shaft/base assembly, and, for spindle-shaft units, press on base (1) to install seal (35) into seal-bore of base (1); pull the seal-installation tools out from around the base/seal. Apply lithium or general purpose bearing grease to roller contact surface of the inner cup (22)., then press inner bearing cone (21) onto shaft (7) until it seats against inner bearing cup (22).
- 7) Prior to installation of the shaft seal (35) (for non-spindle-shaft units), the preload may result in a rolling torque which varies between 70 to 115 in-lb. The bearing preload should be tailored to your application; a low-speed application may require a high pre-load, while high-speed applications usually benefit from low pre-load. Adding shims (26) will increase the pre-load on the bearing set. Determine your pre-load requirement and install shims (26) to obtain this pre-load.

Install the Load-N-Lock™ segments (18) over the shims (26) and into the groove in the shaft (7). Finally, install the lock ring (27) over the segments (18).

All subassembly service or repairs should be complete at this time. Continue to Unit Assembly to complete unit buildup.

Unit Reassembly

- 1) Install the secondary carrier (6) assembly onto the output shaft (7); align the splines of the carrier (6) with the output shaft (7)

splines and slide the carrier onto the shaft.

- 2) Lubricate o-ring(s) (15) and install on the secondary ring gear (3) pilot. Referring to the scribe marks for proper orientation, install the secondary ring gear (3) onto the base (1)

Caution: Hold ring gear(s) by outside diameter or use lifting device to prevent injury.

- 3) Align gear teeth of secondary ring gear (3) with the gear teeth of the planet gears (8) and then align the bolt holes and the scribe line and work the ring gear down into the pilot of the base (1).
 - 4) Lubricate o-ring (15) and install on the outside diameter of pilot of the primary ring gear (2) and install the primary ring gear (2). Refer to scribe marks for proper orientation.
 - 5) Install the sun gear (9) into the secondary planet carrier (6).
 - 6) Install the carrier thrust washer (14).
 - 7) Install primary planet carrier (5) assembly by rotating it and planet gears until the planet gear (10) teeth line up with the ring gear (2) teeth and sun gear (9) spline. Assembly should drop into place.
 - 8) Slide the input gear (11) into the primary planetary carrier (5) assembly.
 - 9) Install the carrier thrust washer (14) and input gear thrust washer (28).
 - 10) Tighten four bolts, placed at 90° to each other, just enough to pull ring gears and base together. Spin test the unit while making sure the base or output shaft turns at least one full revolution; the unit should spin freely without any binding, slowing down or locking of components. Listen for any unusual sounds, such as clicking or grinding noises.
- If no problems are detected, continue to Step 11. If the unit locks up or does not spin freely, tear the unit down to its individual subassemblies; troubleshoot to identify the source of the problem. Correct and continue.
- 11) Remove the 4 bolts from above. Lubricate o-ring (15) and install on the O.D. pilot of the cover (4). with the proper orientation. Install the twenty 5/8-11 capscrews (29) with lockwashers (32) and torque to 220 ft-lbs (dry), 170 ft-lbs (lubed).
 - 12) Fill to proper level, as specified on Page 3, with EP 80/90 gear oil after unit is sealed with a brake and/or motor.

The gearbox is now ready to use.